

Hemchandracharya
North Gujarat University
PATAN-384 265
(Gujarat)



Self Study Report
for
Assessment & Accreditation

: Submitted to:
National Assessment & Accreditation Council
Bangalore

December 2014

Contents

Executive Summary	01
Part A Profile of the University	12
Part B Criterion wise Inputs	29
1. Criterion I: Curricular Aspects	29
2. Criterion II: Teaching-Learning and Evaluation	46
3. Criterion III: Research, Consultancy and Extension	74
4. Criterion IV: Infrastructure and Learning Resources	125
5. Criterion V: Student Support and Progression	147
6. Criterion VI: Governance and Leadership and Management	161
7. Innovation & Best Practices	185
Part C Profile of the Departments	-
Part D Declarations by Head of the Institution	195

Executive Summary

The University campus is very salubrious and well planned spreading over 212 acres of land. HNGU University is having good amenities in the form of well endowed Central Library, excellent Computer Center. Separate hostels for boys and girls, Concerted Sports Complex, Health Center, perfectly clean Canteen, Post Office and Bank are available for University community. The campus life is a mix of rural and urban ethos. The knowledge seekers coming to study by design develop an aptitude for learning because of the innovative curriculum and diverse co-curricular activities that are an integral part of scholar life at Hemchandracharya North Gujarat University.

Ever since its inception in 1986, Hemchandracharya North Gujarat University served the North Gujarat region with enthusiastic zeal to impart qualitative and quantitative education and is looking forward to further expansion of its accomplishments in future to its potential zenith. The system of regular reviews of the existing courses and introduction of new courses of national and international relevance have been a major activity of the University to produce skilled, industry ready and employable human resources.

With hinterland of Hemchandracharya North Gujarat University consisting five districts namely **Patan**, **Mehsana**, **Aravli**, *Banaskhantha* and *Sabarkantha*. The last two districts marked in bold are predominantly situated in tribal areas and the rest are in rural/semi-urban set up. Thus added challenge of the University is to bring the students from tribal and rural areas into the University system for availing the available opportunities of post graduate education and creating a milieu conducive to the education of rural and tribal students.

The HNGU is completely democratic in character. Right from the Department, the statutory bodies/organs like Executive Council, Senate etc., the entire functioning is participatory in point of view. Decisions are discussed and debated in all the bodies which have representatives from all sections of the academic community. A broad spectrum of Committees advise on wide ranging matters pertaining to issues such as campus amenities, institutional collaborations, financial allocations, health care, sabbatical leave, and a host of other issues. In the foreseeable future, the University is going to take up e-governance in a more effective manner. The administrators and non-teaching staff periodically undergo orientation programs in management so as to enhance their functioning in overall context of the University. In brief, the twin aspects of accountability and responsibility mark the governance of the University.

CRITERION I: CURRICULAR ASPECTS

- The design and implementation of curricula at Hemchandracharya North Gujarat University are always planned keeping in mind the university's mission and vision. All major stakeholders are consulted during the process of designing courses and implementing them. This is a systematic, dynamic, democratic, continuous and ever-evolving process.
- There is a considerable amount of autonomy to the faculty, school and department levels for planning and developing curricular aspects. Need-assessment is a continuous process, involving experts, teachers and students; employability, innovation and research needs are taken into account when designing curricula.
- The university has proved to be a pioneer in several areas of curriculum design e.g. Vocational Studies Programme and various other emerging branches of science like Pharma regulation and Drug discovery. Quality sustenance and enhancement are always kept in mind when devising or revising the curricula.
- Admission to Hemchandracharya North Gujarat University is based on rigorous criteria, Merit of 12th standard, rank in competitive examinations and admission tests adapted to the demands of some departments. The university has implemented the Choice-Based Credit System at all levels. New programmes and courses in emerging areas have been introduced like B.Voc. (Fashion Design & Management, Tourism & Hospitality Management), Advance Diploma (Tourism Management, Banking & Insurance, Financial Services, Mobile Communication) PG Diploma in Pharma regulation and Drug Discovery, Industrial Safety.
- Students' feedback is an integral and indispensable part of curriculum design and implementation at HNG University. Such feedback not only shapes the planning and designing of courses; it allows course revision and change after the initial period of implementation. Feedback from experts is crucial for course design and implementation.

CRITERION II: TEACHING-LEARNING AND EVALUATION

- Admission to HNG University is completely transparent and student-friendly process, from application to declaration/publication of admission test results; and details are accessible to everyone. The process is reviewed on yearly basis and improvements, if necessary, are implemented (e.g. Centralized admission online and online enrollment process, online exam forms) on a regular basis.
- Students from backward and disadvantaged sections of society, especially those from remote rural areas, are encouraged to apply;

there are many schemes and programmes for such students, including, scholarships, and Special hostel for SC/ST students, special facilities for differently-abled students and provision for remedial coaching.

- In addition to remedial courses, the university also offers preparation of competitive exams UPSC, GPSC, Bank PO, and many more... soft skills and other courses beyond regular class hours through GARDI CHAIR, Now University has SPIPA nodal study center with residential facility for preparations of Civil and other allied services.
- Orientation classes at the beginning of the academic session are a regular feature for the students to brief about facilities available to them (e.g. library and medical facilities, counseling services, Remedial classes); the university's zero-tolerance policy with regard to ragging and sexual harassment, among others. Student representation at various statutory bodies provides a platform to make the student community's views identified and contribute to planning for the future.
- Group learning, tutorials, mentoring, interaction with national and international experts, collaboration with industry, and involvement in project work from the undergraduate level onwards, free internet access and extensive laboratory work are some of the steps taken to make learning at HNG University student-specific.
- Innovations in teaching, encouragement of student participation in seminars and symposia, involving students in all important decisions have successfully combined to create an atmosphere of openness, creativity and flexibility.
- The HNGU faculty is well qualified and their research output is sizeable. Evidence to this is borne by research projects awarded by different agencies like ICSSR, DST, CSIR, GUJCOST, GSBTM to Faculty.
- India Today Institutions Rankings June 2013 has ranked HNG University at 48 in India among all institutes of higher education on basis of Reputation, Quality of academic input, Student care, Infrastructure, Job prospectus, Faculty, Research publication, Innovation and governance.
- The university's Examination Section is well-staffed and well equipped; all examinations are held on time and results published on schedule; choice-based credit system (CBCS) are in place at all levels; examination rules are reviewed timely; there is provision for review and redressal; all university results can be seen online; there is increased use of IT for evaluation, although more remains to be done in this area.

CRITERION III: RESEARCH, CONSULTANCY AND EXTENSION

- Research of a very high quality has been promoted and sustained at HNG University since its inception. Research in any field or discipline

at the university is conducted keeping in mind the latest developments, relevant to local, regional, national and international.

- University has taken initiative for promoting research and organized Research Marathon in three phases like Research Initiatives training workshop under which all participants from university, affiliated and constituent colleges prepared research proposals in various interdisciplinary areas and submission to different funding agencies like UGC, ICSSR, DST, CSIR, GUJCOST, GSBTM and many more.
- In all the three phases, nearly 150 participants' participated and 62 proposals were prepared for submission. HNGU in association with AIU organized one workshop "*March towards the Research*" on research saw a participation of 127 people from various affiliated colleges in North Gujarat region. The efforts bore a fruit and the university has received a total of Rs. 27628347/- in the form of research grants from above mentioned funding agencies.
- University facilitates faculty member to undertake research in emerging disciplines by providing research funds (seed money). Rs. 15 lac has been disbursed amongst the faculty members from the World Class Uni. Grant (SG). Rs. 10 lac is to be disbursed amongst the Students for their research under the World Class Uni. Grant (SG). University also encourages faculties to attend National/International workshops, paper presentation, poster presentation and expenses incurred on such activities are borne by the university.
- Recently our faculty from Department of Commerce and Management, Dr. A G Modi, got prestigious Raman Fellowship (Post Doctoral) under Indo-US bilateral cooperation.
- The College Development Committee of the University is providing guidance to affiliated/constituent colleges for teaching and research innovations.
- The university has Central Instrumentation facility in the Department of Chemistry where all kinds of sophisticated equipments are available for characterization and analytical studies. Residential facilities to research scholars, research fellows are available on request. The UGC Area Study Center for Indian Diaspora and Cultural Studies is very unique and HNGU shares this honour with two or three Universities in India. The establishment of SPIPA Nodal center is another achievement on the part of HNGU
- Research Awards are given to faculty members based on Impact Factor of Research Publications. A total of 400 research papers were published in international/national journals
- HNGU faculty has published 96 books with well-known national/international publishers.
- University has a number of collaborations with prestigious universities across the world like, California State University, San Bernardino, USA, Georgia South Western State University, USA, Bio-nut Research

Foundation, Netherlands, University of Groningen, Netherlands, United State Department of Agriculture, USA, and De Montfort University-UK, etc.

- The University has a research Committee known as Research Development Committee (RDC) which monitors and addresses issues related to research and Ph.D. programs. The University strictly follows the UGC specified minimum standards and procedures for the award of Ph. D. Degree Regulations 2009.
- A soft copy of the thesis (PDF format) is forwarded to INFLIBNET and the same PDF format in CD is forwarded to the UGC, New Delhi. University has installed research software like SPSS, Matlab, PROWESS, capitaline CL 2000, ACE Analyzer (Accord Fintech) etc. For promotion of the various research activities University is subscribing to online research sources like Proquest, DELNET, relevant journals, books, magazines, etc. discipline wise.
- Faculty members and students have not only attended national and international conferences in India and abroad but have also delivered invited/ plenary/lead lectures. University has organized a number of national and international conferences, symposia, workshops, round tables, which were attended by eminent personalities from academic as well as industry.

CRITERION IV: INFRASTRUCTURE AND LEARNING RESOURCES

- The University has an aesthetically beautiful, well planned and spacious green campus which is spread over 212 acres of land with facilities of Central library, Computer center, Hostels for Men & Women, Well developed Sport complex, VIP guest house, Health center, Canteen, Post office and Bank.
- University has a well laid 400 meter Track for athletics, separate grounds for Hockey, Football, Handball, Khokho & Kabbadi. Different courts for Volleyball, Tennis Court, Basket Ball, Badminton, Softball. The University has Gymnasium facility for students and faculties for fitness and also enclosure for Judo and Wrestling.
- University has acquired new campus of 100 acres located at Vadali Dist: Sabarkantha for further expansion and access to stake holders on even basis. The university is planning to start new faculties in Agriculture, Horticulture and Forest related studies taking into consideration the surroundings flora and fauna.
- University has developed Central Instrumental Facility - CIF under UGC scheme where all sophisticated instruments are kept. All departments of university are having adequate number of computer facility with internet.

- The Health center of the university provides health services to teaching, non-teaching staff and students.
- The University Library is a spacious two-storied building (2486 sq. m.) with a capacity of 237 seats with AC Reading Hall. The facilities available in the Central Library are mentioned below:
 - Over 69,832 printed versions of reference books
 - Total No. of Journals Subscribed: 110
 - Total No. of Ph.D Thesis: 1138
 - Total No. of Master degree dissertations: 1094
 - Total No. of Audio-Video collections: 841
 - Online resources - subscription of DELNET, Bentham Pharmacy, UGC Infonet
 - Latest version of SOUL 2.0 is in use
 - Online Public Access Catalog (OPAC).

As library uses SOUL for issuing books, library operations are smooth and user-friendly.

- University has very good IT Infrastructure with 10 latest configuration servers, 82 laptops and about 800 computers which are used by teaching, non teaching staff and students. University is going to establish its new WAN with 1 GBPS Bandwidth using fiber optic connectivity.
- University adequately allocates resources for upgradation, beautification and maintenance of its physical infrastructure regularly.

CRITERION V: STUDENT SUPPORT AND PROGRESSION

- The university provides mentoring, personal counseling, career guidance, day-care centre, remedial coaching, and training in soft skills to all students who want to avail of them.
- The GARDI Chair of the university provides coaching to students who are planning to appear in various competitive examinations of State and National level (UPSC,GPSC, Bank PO, Railways, POST, NET, SLET, and many more). These coaching classes are conducted after the regular class hours, students can join these classes by paying a nominal fee.
- The university also has a Career Counseling and Placement cell which facilitates the students to prepare themselves for more competitive world of industry and commerce requirements.
- The Career Counseling and Placement cell tries to fetch national and international companies/organizations to come to the university to interview potential recruits. Student progression figures for the university are excellent and student involvement in university activities is actively encouraged and adds much to the university's dynamic nature. Department-level student-teacher committees are active and

students are encouraged to let their voices and views known to university.

- Statutory bodies like the Anti-Ragging Committee and the Committee against Sexual Harassment (CASH) actively encourage student participation in their awareness programmes. SC/ST Cell, Equal Opportunity Cell works for weaker section students. There are many scholarships available for students and the university department helps and support students for getting freeships and scholarships.
- The university has an effective Alumni Association with branches spread across the globe. The differently able and visually impaired student requirements are adequately taken care of by the University.
- The university's Management club is active and organizes state level event "WISDOM" which attracts a lot of attention in the academic and student community. The university fest "Youth Festival" is organized by the university every year to encourage a spirit of self-reliance, value-system, and to impart vital lessons in teamwork and enhance organizational abilities.
- University's NSS section organizes various activities for student and social welfare in affiliated colleges of university, University's Physical education department organizes various sports competition for university students regularly for university and affiliated colleges for participation in inter, zonal and national level University sports tournaments.
- Student's feedback is taken and analyzed for planning and developing support activity for students.

CRITERION VI:

GOVERNANCE, LEADERSHIP AND MANAGEMENT

- The University's vision, mission and goals meet the objectives of higher education set by the National Knowledge Commission. The University has been providing leadership in academic and administrative matters to all affiliating colleges including colleges with Potential for Excellence. The body which acts as a bridge between the colleges and the university administration is the College Development Council (CDC). The colleges are encouraged to establish research centers, for new curriculum development tapping of the faculty expertise for Board of Studies meetings and college teachers are co-opted as members on various bodies. Continuous and rigorous monitoring of selection of teachers, principals, affiliation, and conduct of examinations is done by University through statutory structures and processes.
- The University is striving to maintain high standards of teaching and research in all the Departments. This is amply evident from the quality and quantity of research publications published by the faculty.

Nurturing and reinforcing this culture of excellence is the hallmark policy. This has been sought to be achieved through a system of recognition and rewards as well as implementing IQAC modalities.

- The University is highly aware of its obligations to society and their functional manifestations by way of contribution towards national development necessitate high quality research work. This aspect is borne by the fact that several faculty members have won assignments under one or the other prestigious fellowship programmes e.g. Raman fellowship, International Scholar Exchange Programme.
- Social values are reflected in social service activities undertaken by the University viz. Blood donation camps, campus cleanliness drive, Green campus drive, NSS camps, Voter awareness campaign, etc. As per the vision and mission statement of the University the University has evolved several strategies for enhanced Teaching-Learning, Research and Development, Community Engagement, Human resource planning and development and active interaction with Industry.
- The establishment of IQAC in 2009 has given a quantum leap in achieving excellence of the goals set. Specific measures initiated are: digitization of the Records, Enhancing e-resources, On-line admission process, Online Enrollment, Online exam form, promotion of quality research work and adoption of CBCS from 2011-12 session onwards.
- The University finances are managed primarily through the office of the Chief Account Officer. There is a meticulously planned University budget each year that is debated rigorously in the Finance Committee and Executive Council before adoption for implementation. HNGU is the only university in Gujarat which has adopted double entry system. The Local Fund Audit department is an independent audit department under the administrative control of Finance Department of the State Government which audits the accounts of university annually.
- A system of internal and external audit ensures transparency and efficiency in the University finances. Several new self financed courses have been initiated to augment resources. Other channels of resource mobilization include major/minor project proposals to various external funding agencies e.g. UGC, ICSSR, philanthropist's donation. These donations have given leverage to university in maintaining reserve and corpus funds.
- The university has initiated an innovative perspective plan for future which is named as "*Chalo Gaon Chale*". Aim of this plan is to initiate activities in selected villages by university departments for overall clean, green and self-sustained development.

CRITERION VII: INNOVATIONS AND BEST PRACTICES

- The University has laid special emphasis on Environmental Consciousness. The University is going to implement a Green University Policy which includes:
 - Energy Audit of the campus,
 - Implementation of Solar Water Heating System,
 - Construction of Bio-methanization Plants,
 - Green Buildings,
 - Water Recharging,
 - Battery operated system of locomotion on the campus,
 - Solid Waste Management system,
 - Scientific Study of Tribal Techniques of environmental protection,
 - Green House Protocol,
 - Pedestrian pavements,
 - Awareness drives for Green Campus.
 - Establishment of Books corner
 - Conducting Safety Inspection and audit
- The campus has been sought to be made eco-friendly with targets of saving energy and fuel. In this regard, awareness will be created by celebrating various days like the Earth Day, World Food Day, Traffic Week, National Science Day, World Aids Day, World Environment Day, National Youth Day, etc. Each of these celebrations will include some form of activity as well.
- The University has adopted several Best Practices, two of which have been selected for illustration. The *first* Best Practice is – Rationalization of human resources adopting ICT procedures. The *second* Best Practice adopted is – Innovative Courses, Programmes with self-support.
- The University now has many such self-financed course/programmes operational. One of the leading programmes in this regard is M.Sc (CA & IT) five years integrated and LLM two years programme. The University offers these courses in Law, Management, Computer Science, Physics, BBA, Biotechnology, Social work, Journalism, Library and Information science, Education, Physical Education, Pharmaceutical Sciences, etc
- Also initiated courses with support from UGC which fosters employability like B.Voc. (Bachelor of Vocational studies), CC (Community college), COC (Career Oriented Course), all these courses are not traditional courses and focus on employability of students.

SWOC Analysis

Strengths:-

- Highly qualified and experienced permanent teaching staff and Majority of them with Ph.D. degrees.
- University is having a sprawling campus of 212 Acres with expansive buildings.
- Existence of University and Industry Linkage Cell, Women Cell, Career counseling Cell, Committee Against Sexual Harassment
- Free Hostel facility with lodging and boarding within institution's campus for ST Boys and Girls.
- Well developed labs having latest facilities, State of Art instruments for teaching and research.
- Ergo Eco friendly designed spacious reading room with comfortable seating facility for students and research scholars with Air conditioned facility
- Well developed Sport complex, Gymnasium, Health center, Canteen, Post office, Employment Office, Bank are inside the university campus
- Sponsored chairs for preparing students for various competitive exams

Weakness

- Serious dearth of permanent teaching/non-teaching staff
- Less involvement of institute in research activities due to affiliation in character
- Low investments/emphasis on image building and branding
- Limited automation of administrative and exam activities
- Due to affiliating nature heavy administrative burden

Opportunities

- Looking for more linkages with reputed institutions at National and International level
- Surpassing the present accreditation with the forth coming NAAC reaccrreditation.
- Deploying and adopting ICT & E-learning techniques in teaching
- Strengthening Industry academia collaboration
- Development of research aptitude among students
- Enhancing placement supports to the students.
- Institutionalizing consultancy and extension activities

Challenges

- University located in rural and tribal setup with many demographic limitations.
- Aptitude of students for English language
- The population is of low income group, Education of parents are even low hence the students from these areas are unable to afford self finance courses
- Non availability of NET/SLET qualified fulltime research scholars
- Very few Grant in Aid departments in the university campus

Profile of the University

1 Name and Address of the University:

Name:	Hemchandracharya North Gujarat University		
Address:	University Road, Patan		
City: Patan	Pin: 384265	State: Gujarat	Website: www.ngu.ac.in

2 For Communication:

Designation	Name	Tele. with STD Code	Mobile	Fax	Email
Vice Chancellor	Dr. R. L. Godara	O:0276 6-230456	95580959 21	02766 - 23364 9	vc@ngu.ac.in
Pro Vice Chancellor (s)	Dr. Dipoooba Devda	O:0276 6-231814	94275464 55	02766 - 23191 7	pvc@ngu.ac.in
Registrar	Dr. Dilip C. Patel	O:0276 6-230427	97129031 88	02766 - 23191 7	regi@ngu.ac.in
Steering Committee /	Dr. Adesh Pal	O:0276 6-233648	85111202 55	02766 - 23191 7	hod_english@ngu.ac.in
IQAC Co-ordinator	Dr. S. A. Bhatt	O:0276 6-220932	99989815 60	02766 - 23191 7	Shreyas_bhatt@yahoo.co.in

3. Status of the University:

State University

State Private University

Central University

University under Section 3 of UGC (Deemed University)

Institution of National Importance

Any other (please specify)

4. Type of University:

Unitary

Affiliating (✓)

5. Source of funding:

Central Government

State Government

Self-financing

Any other (please specify)

6. a. Date of establishment of the university: 17/05/1986

b. Prior to the establishment of the university, was it a/an

i. PG Centre Yes No

ii. Affiliated College Yes No

iii. Constituent College Yes No

iv. Autonomous College Yes No

v. Any other (please specify)

.....

If yes, give the date of establishment Not Applicable

7. Date of recognition as a university by UGC or any other national agency:

	Under Section	DD	MM	YYYY	REMARKS
i	2f of UGC*	21	02	1996	-
ii	12B of UGC *	21	02	1996	-
iii	3 of UGC #	-	-	-	-
iv	Any other ^ (specify)	-	-	-	-

* Enclose certificate of recognition.

Enclose notification of MHRD and UGC for all courses/ programmes/ campus/campuses.

^ Enclose certificate of recognition by any other national agency/agencies, if any.

8. Has the university been recognized

a. By UGC as a University with Potential for Excellence?

Yes No

If yes, date of recognition: Not Applicable

b. For its performance by any other governmental agency?

Yes No

If yes, Name of the agency Not Applicable and
date of recognition: Not Applicable

9. Does the university have off-campus centres?

Yes No

If yes, date of establishment: Not Applicable

If yes, date of recognition: Not Applicable

10. Does the university have off-shore campuses?

Yes No

If yes, date of establishment: Not Applicable

date of recognition: Not Applicable

11. Location of the campus and area:

		Location*	Campus area in acres	Built up area in sq. mts
i.	Main campus area	Patan-Rural	223	75,876
ii.	Other campuses in the country	-	-	-
iii.	Campuses abroad	-	-	-

Very recently the government of Guajrat has allocated the 200 acre land in tribal area – Vadali, Dist.: Sabarkantha to develop the campus and offer various courses to tribal community of the area.

(* Urban, Semi-Urban, Rural, Tribal, Hilly Area, Any other -please specify)

If the university has more than one campus, it may submit a consolidated self-study report reflecting the activities of all the campuses.

The university, very recently, has completed the formality for acquiring the land. The university has plan to develop the campus in next three year time period.

12. Provide information on the following: In case of multi-campus University, please provide campus-wise information.

➤ **Auditorium/seminar complex with infrastructural facilities.**

There are Five Auditoriums in the University. They are as follow:

- (i) Gandhi Smruti Hall – 200 seat Capacity
- (ii) Rang Bhavan – 375 seat Capacity

The other three are under construction and at final stage they are

- (iii) Convention Hall – Unit 1 – 800 seat capacity
- (iv) Convention Hall – Unit 2 – 350 seat capacity
- (v) Convention Hall – Unit 3 – 150 seat capacity

➤ **Sports facilities**

- Playground – Play ground for all types of games are available in the university campus. Games are (i) Hockey (ii) Cricket (iii) Volley Ball (iv) Track for 400 mtr. (v) Basket Ball (vi) Football (vii) Handball (viii) Kho-kho (ix) Kabbadi (x) Tennis court (xi) badminton court (xii)

- Swimming pool–swimming pool facility is not available in the university campus
- Gymnasium – Gymnasium is available in the university.
- Any other (please specify) – Facility of Gym for the students of the university is also available in the campus

➤ **Hostel**

Boys' hostel

- Number of hostels - 03
- Number of inmates - 612
- Facilities– The following facilities are available in the boys' hostel:
 - Dinning facility
 - Water cooler
 - RO Plant for safe drinking water,
 - Geyser facility for hot water

Girls' hostel

- Number of hostels - 03
- Number of inmates - 288
- Facilities– The following facilities are available in the Girls' hostel:
 - Dinning facility
 - Water cooler
 - RO Plant for safe drinking water
 - Geyser facility for hot water

Working women's hostel

There is no working women hostel facility available in the university campus.

- Number of hostels - 00
- Number of inmates -00
- Facilities– Not Applicable

➤ **Residential facilities for faculty and non-teaching**

University takes due care of its employees. The university has residential quarters for non-teaching as well as teaching employees. For Teachers of the university there are six bungalows available. For Non-teaching staffs there are separate quarters for officers and clerks and class IV employees.

There is one wing consisting of six flats for officers. There is one wing consisting of six flats for supervisory cadre. There are five wings each consisting of six flats for clerical staff and there are four wings for class IV staff each consisting of six flats.

➤ **Cafeteria**

There are two Cafeterias available for students and staff of the university. Apart from the cafeterias there is also an Amul parlour present in the campus.

➤ **Health centre – Nature of facilities available –inpatient, outpatient, ambulance, emergency care facility, etc.**

A health centre is also available within the university campus. A qualified doctor is available to students and staff of the university for two hours in the morning and two hours in the evening.

There is no ambulance available or possessed by the university. However, in case of emergency, services of ‘108’ is used. The ambulance service provided under 108 services is very efficient. The ambulance reaches within average time of 5 minutes once the call is made.

As there is no hospital available on the campus, there is no IPD (inpatient department) facility available.

➤ **Facilities like banking, post office, book shops, etc.**

All amenities like bank, post office, stationary shop etc are available on the university campus. State Bank of India is having its branch within campus. There are two ATMs (State Bank of India and HDFC Bank) located on the campus. There is also a branch of the post office on the campus.

A stationary shop selling books and all other stationary is also present in the campus.

➤ **Transport facilities to cater to the needs of the students and staff**

The university has one pickup vehicle and one 56 seated bus to cater to the needs of the students and staff. There is no vehicle facility available for students and staff of university commuting from outside Patan.

➤ **Facilities for persons with disabilities**

Some facilities are available for persons with disabilities. Facilities for disabled will be ensured in the new buildings constructed by the university.

- **Animal house**
No animal house is present in the university.
- **Incinerator for laboratories**
No incinerator for laboratories on the university.
- **Power house**
Power house in the form of generator is available for administrative building only.
- **Waste management facility**
Waste management is done by estate department of the university which has hired people on contractual basis through agency for the purpose.

13. Number of institutions affiliated to the university

Number of affiliated U.G.colleges – 302
 Number of affiliated P.G. college – 29
 Number of P.G. Centres run by affiliated colleges - 41

14. Does the University Act provide for conferment of autonomy (as recognized by the UGC) to its affiliated institutions? If yes, give the number of autonomous colleges under the jurisdiction of the University.

Yes, No college has yet applied for autonomy.

Type of colleges	Total	Permanent	Temporary
Arts, Science and Commerce	85	85	-
Law	06	06	-
Medicine	15	15	-
Engineering	00	00	-
Education	96	96	-
Management	77	77	-
BSW/MSW	14	14	-
Architecture	01	01	-
Rural Studies	08	08	-
Others - B.Voc	02	-	02
- Community College	02	-	02

15. Furnish the following information:

	Particulars	Number
a.	University Departments	
	Under graduate	01
	Post graduate	18
	Research centers on the campus	02
b.	Constituent colleges	02
c.	Affiliated colleges	331
d.	Colleges under 2(f)	84
e.	Colleges under 2(f) and 12B	84
f.	NAAC accredited colleges	84
g.	Colleges with Potential for Excellence (UGC)	04
h.	Autonomous colleges	00
i.	Colleges with Postgraduate Departments	41
j.	Colleges with Research Departments	00
k.	University recognized Research Institutes/Centers	00

16. Does the university conform to the specification of Degrees as enlisted by the UGC?

Yes, the university conforms to the specification of Degrees as enlisted by the UGC. The university does not have any other nomenclatures.

17. Academic programmes offered by the university departments at present, under the following categories: (Enclose the list of academic programmes offered)

Programmes	Number
UG	05
PG	26
Integrated Masters	01
M.Phil.	14
Ph.D.	30
Integrated Ph.D.	00
Certificate	03
Diploma	05
PG Diploma	06
Total	90

Academic programmes offered by the university departments are as follow:

Sr. No.	Department	Programmes offered
01	Department of Chemistry	M.Sc., P.G.D. in Drug Discovery & Drug Development M.Phil., Ph.D
02	Department of Commerce and Management	M.B.A., M.Com., M.Phil (Commerce)., Ph.D
03	Department of Computer Science	M.C.A., M.C.A. (5 Yr Integrated) M.Sc (CA & IT), Ph.D, P.G.D.C.A., Ph.D.
04	Department of Education	M.Ed., M.A. (Edu.), M.Phil., Ph.D.
05	Department of English	M.A., M.Phil., Ph.D.
06	Department of Journalism & Mass Communication	M.J.M.C., M.Phil.
07	Department of Law	L.L.M., M.Phil., Ph.D.
08	Department of Library & Information Science	B.Lib., M.Lib., Ph.D.
09	Department of Life Sciences	M.Sc. (Microbiology/Botony/ Environmental Science), M.Phil., P.G.D.M.L.T., P.G.D. in Industrial Safety & Environment Mangement, Ph.D.
10	Department of Biotechnology	M.Sc., M.Phil., Ph.D.
11	Department of Mathematics	M.Sc., Ph.D.
12	Department of Physical Education & Yoga Centre	B.P.Ed., M.P.Ed., M.Phil., Dip. In Yoga Edu., P.G.Dip. in Yoga Edu.
13	S K College of Business Management	B.B.A., B.Com., B.Voc. (Fashion Design & Management, Tourism & Hospitality Management), Advance Diploma(Tourism Management, Banking & Insurance, Financial Services, Mobile Communication),
14	Department of Sanskrit & Bhartiya Vidya	M.A., M.Phil., P.G.D.in Prakrit & Apbhransh, Ph.D.
15	Department of Social Work	B.S.W., M.S.W., Ph.D.
16	Department of Hospital Management	M.H.M., P.G.D.H.M.
17	Department of Physics	M.Sc. (Physics), M.Sc.(Electronics)

18	Department of Pharmaceutical Science	M.Pharm.
19	Institute of Architecture	B.Arch., M.U.P., M.D.Ed.
20	UGC Area Study Centre for Indian Diaspora and Cultural Studies	M.Phil., Ph.D.

- 18. Number of working days during the last academic year.**
Number of working days in last academic year was 220.
- 19. Number of teaching days during the past four academic years.**
180 days of every year in the past four years.
(‘Teaching days’ means days on which classes were engaged.
Examination days are not included)
- 20. Does the university have a department of Teacher Education?**
Yes
If yes,
a. Year of establishment 15/06/2005
b. NCTE recognition details (if applicable) No.: 325015
Date: 25/06/2005
c. Is the department opting for assessment and accreditation separately?
No
- 21. Does the university have a teaching department of Physical Education?**
Yes
If yes,
a. Year of establishment: 14/06/2000
b. NCTE recognition details (if applicable)
Notification No.: 324043 (B.P.Ed.)
324017 (M.P.E.)
Date: 03/11/2003 (B.P.Ed.)
Date: 13/11/2002 (M.P.E.)
c. Is the department opting for assessment and accreditation separately? No
- 22. In the case of Private and Deemed Universities, please indicate whether professional programmes are being offered? If yes, please enclose approval / recognition details issued by the statutory body governing the programme.**
Not Applicable
- 23. Has the university been reviewed by any regulatory authority? If so, furnish a copy of the report and action taken there upon.**

University has been reviewed by NAAC committee in 2008. The copy of the report and action taken there upon are attached as

Appendix-1

The university has also been awarded the ISO 9000:2008 certificate. (Appendix -2)

24. Number of positions in the university (Grant in Aid)

Positions	Teaching faculty			Non-teaching staff	Technical staff
	Professor	Associate Professor	Assistant Professor		
Sanctioned by the UGC/ University/ State Government	11	17	22		
Recruited	04	06	15	98	00
Yet to recruit	07	11	07	33	00
Number of persons working on contract basis/Self finance Basis	01	00	21		

25. Qualifications of the teaching staff (Grant-in-Aid Programmes)

Highest Qualification	Professor		Associate Professor		Assistant Professor		Total
	Male	Female	Male	Female	Male	Female	
Permanent teachers							
D.Sc./D.Litt.							
Ph.D.	08	02	04	01	06	03	24
M.Phil.							
PG			01		01		02
Temporary teachers							
Ph.D.						01	01
M.Phil.					01	06	07
PG					05	04	09
Part-time teachers							

Highest Qualification	Professor		Associate Professor		Assistant Professor		Total
	Male	Female	Male	Female	Male	Female	
Ph.D.							
M.Phil.							
PG							

Qualifications of the teaching staff (Self Financed Programmes)

Highest Qualification	Professor		Associate Professor		Assistant Professor		Total
	Male	Female	Male	Female	Male	Female	
Permanent teachers							
D.Sc./D.Litt.							
Ph.D.	01			01	12	06	20
M.Phil.							
PG					10	03	13
Temporary teachers							
Ph.D.							
M.Phil.							
PG							
Part-time teachers							
Ph.D.					01	01	02
M.Phil.						01	01
PG					01	04	05

26. Emeritus, Adjunct and Visiting Professors

	Emeritus	Adjunct	Visiting
Number	-	-	176

27. Chairs instituted by the university

School/ Department	Chairs
- -	-

28. Students enrolled in the university departments during the current academic year (2013-2014), with the following details

Students	UG	PG	Inte- grated Masters	M. Phil.	Ph.D.	Inte- grated Ph.D.	D.Litt./ D.Sc.	Certifi- cate	Diploma	PG Diploma
	*M *F	*M *F	*M *F	*M *F	*M *F	*M *F	*M *F	*M *F	*M *F	*M *F
From the state Where the University is located	196 (105 +91)	651 (326 + 325)	66 (45 +21)		12 (09 + 03)	-	-	74 (33+41)		
From other states of India	00 +02	07+ 06	-	-	-	-	-	04 (04+00)		
NRI students	-	-	-	-	-	-	-	-	-	-
Foreign students	-	-	-	-	-	-	-	-	-	-
Total	198 (105 + 93)	664 (333 + 331)	66 (45 +21)	256 (138 +118)	12 (09 + 03)	-	-	78 (37+41)		

*M - Male *F – Female

29. 'Unit cost' of education

(Unit cost = total annual recurring expenditure (actual) divided by total number of students enrolled)

(a) Annual recurring expenditure Including the salary component
= Rs. 27,03,32,232.00
Total number of students enrolled in the university campus= 2987

'Unit Cost' of education = Rs. 90503

(b) Annual recurring expenditure Excluding the salary component
= Rs. 18,93,93,325.00
Total number of students enrolled in the university campus = 2987

'Unit Cost' of education = Rs. 63406

30. Academic Staff College:

Does not exist in the university at present but the university, recently, has sent a proposal to establish an Academic Staff College to

the UGC.

- Year of establishment - (Not Applicable)
- Number of programmes conducted (with duration) - (Not Applicable)

* UGC Orientation, * UGC Refresher, * University's own programmes - (Not Applicable)

- 31. Does the university offer Distance Education Programmes (DEP)?**
No

If yes, indicate the number of programmes offered. Are they recognized by the Distance Education Council?

Though the university does not have its own Distance Education Programme, it has regional study centres of IGNOU and Baba Saheb Ambedkar Open University. Various programmes are offered for the learners of the region including Arts, Commerce faculty and Computer Related.

- 32. Does the university have a provision for external registration of students?**

Yes. The university offers the external registration for students of Arts and Commerce for post graduate programmes only.

If yes, how many students avail of this provision annually?

The following data shows number of students enrolled for external registration of various programmes:

<u>Year</u>	<u>Arts</u>			<u>Commerce</u>		
	<u>Part-I</u>	<u>Part-II</u>	<u>Total</u>	<u>Part-I</u>	<u>Part-II</u>	<u>Total</u>
Year 2013-14	9332	5085	14417	2215	0626	2841
Year 2012-13	6521	4588	11109	1054	0498	1552
Year 2011-12	6833	3781	10614	0819	0330	1149
Year 2010-11	5337	3404	08741	0743	0364	1107
Year 2009-10	4394	2827	07221	0527	0356	0883

- 33. Is the university applying for Accreditation or Re-Assessment? If Accreditation, name the cycle.**

Accreditation : Cycle 2

Re-Assessment: No

- 34. Date of accreditation Cycle 1:** 16/09/2008
Accreditation outcome/Result: Grade B, Gr.Pt.: 2.55

Kindly enclose copy of accreditation certificate(s) and peer team report(s)

Copy of accreditation certificate and peer team report is attached as Appendix -3

- 35. Does the university provide the list of accredited institutions under its jurisdiction on its website? Provide details of the number of accredited affiliated / constituent / autonomous colleges under the university.**

No, University does not provide list of accredited institutions under its jurisdiction on its website.

Following is the list of colleges which have got accredited by the NAAC:

HEMCHANDRACHARYA NORTH GUJARAT UNIVERISTY,PATAN			
YEAR-2014-15			
SR NO.	COLL_NAME	CITY	GRADE
1	L.N.K. College Of Education[Cte]	Patan	A
2	Shri U. P. Arts, Smt. M. G. Panchal Science & V. L. Commerce College	Pilvai	A
3	Shri V.R. Patel College Of Commerce	Mehsana	A
4	Pramukh Swami Science & H.D. Patel Arts College	Kadi	A
5	Ahmedabad Homeopathic Medical College	Ahmedabad	A
6	R.R. Mehta College Of Science & C.L. Parikh College of Arts	Palanpur	A
7	Swami Vivekanand Sarvoday Bank Education College	Mehsana	A
8	Shri H.S. Shah College Of Commerce	Modasa	A
9	Municipal Arts & Urban Science College	Mehsana	B++
10	Smt. S.M. Panchal Science College	Talod	B+
11	The Chansma N.S. Bank Ltd. Arts & B.A.Patel & D.B. Vyas Commerce College	Chanasma	B +
12	Shri S.K. Shah & Shri Krishana O.M. Arts College	Modasa	B+
13	Sir P.T. Science College	Modasa	B+
14	Shri B.P.B. Arts & M.H. Guru Commerce College	Unjha	B+
15	Shri S.S. Mehta Arts & M.M. Patel Commerce College	Himatnagar	B+
16	Shri B.D. Shah College Of Education	Modasa	B+

17	Shri N.S. Patel Law College	Modasa	B+
18	Smt. A. S. Chaudhari Mahila Arts College	Mehsana	B+
19	Smt R.M. Prajapati Arts College	Satlasana	B+
20	Divyachetana College Of Education	Bhetali	B
21	Mahila B.Ed. College	Unjha	B
22	Maneklal Nanchand College	Visnagar	B
23	Sheth H.P. Arts & Talod Sahakari Mandli Commerce College	Talod	B
24	G.D. Modi College Of Arts	Palanpur	B
25	Smt. C.C. Mahila Arts & Sheth C.N. Commerce College	Visnagar	B
26	College Of Education	Daramali	B
27	Shri D.D. Choksi College Of Secondary Education	Palanpur	B
28	Smt. T. S. R. Commerce College	Patan	B
29	Sheth M.N. Law College	Patan	B
30	The Dhansura Peoples Co-Op Bank Ltd Arts & Commerce College	Dhansura	B
31	Kheralu Nagarik Sahakari Bank Ltd. Arts & Commerce College	Kheralu	B
32	Arts College	Shamlaji	B
33	Law College	Himatnagar	B
34	Sheth M.N. Science College	Patan	B
35	Shri J.M. Patel Arts & Smt. M.N. Patel Commerce College	Unjha	B
36	Smt. M.M. Shah Mahila Arts College	Kadi	B
37	Smt.P. R. Patel Arts College	Palasar	B
38	The Himmatnagar Nagarik Sahakari Bank Ltd. Science College	Himatnagar	B
39	Mahila Arts College, Motipura	Himatnagar	B
40	The Sarvoday Nagarik Sahakari Bank Ltd. Mahila Arts College	Himatnagar	B
41	Mahila Arts College	Vijapur	B
42	Lokniketan Mahavidhalay (BRS Programme)	Ratanpur	B
43	B.M. Shah Mahavidhalay	Zilia	B
44	Nima Girls Arts College	Gozariya	B
45	B. K. Mercantile Bank Law College	Palanpur	B
46	Smt.Jayaben Dhirajlal Thakkar B.Ed.College	Radhanpur	B
47	Revaba Sarvajanic Education Colleges	Mehsana	B
48	Amarjyot M.Ed. College	Radhanpur	B
49	New Progressive College Of Teachers' Education	Mehsana	B

50	Sheth C.N. Arts & B.D. Commerce College	Kadi	B
51	Gramseva Mahavidhlay Grambharati	Amrapur	B
52	D.D. Thakar Arts & K.J. Patel Commerce College	Khedbrahma	B
53	Vijaynagar Arts College	Vijaynagar	C++
54	Secondary Teachers Training College	Visnagar	C
55	Sheth V.S. Law College	Unjha	C
56	Smt. M.C.Desai Arts & Commerce College	Prantij	C
57	Adivasi Arts & Commerce College	Bhiloda	C
58	Talakchand Mayachand Shah Mahila Arts College	Idar	C
59	Arts College	Vadali	C
60	M.M.Chaudhari Arts College	Rajendranagar	C
61	College Of Computer & Management Studies	Vadu	C
62	Kadva Patel B.Ed College	Ghaghret	C

36. Date of establishment of Internal Quality Assurance Cell (IQAC) and dates of submission of Annual Quality Assurance Reports (AQAR).

IQAC establishment date: 28/09/2010

AQAR submission dates:

- (i) 28/09/2010
- (ii) 28/09/2010
- (ii) 08/12/2014
- (iii) 08/12/2014
- (iv) 08/12/2014

Any other relevant data, the university would like to include (not exceeding one page).

CRITERION I: CURRICULAR ASPECTS

1.1 Curriculum Design and Development

1.1.1 How is the institutional vision and mission reflected in the academic programmes of the university?

The academic Programme developed by the University helps students to develop as citizens with knowledge, skill and character leading to social transformation and national development as per the vision and mission of the University. The university's academic environment encourages teachers to think creatively and teach in an innovative manner. There are separate and spacious buildings for each programme that are offered in the university. Most of the department in the university uses latest tools and techniques for teaching learning. Teachers and officers of the university are equipped with latest configured laptop. There are 796 computers in the university campus for use by students, teachers and non teaching staff of the university. Every department and administrative office has internet facility. Some of the departments of the university are also wi-fi enabled. The university has planned to make entire campus wi-fi. To encourage research among teachers of university departments and affiliated colleges, the university conducted workshops in three phases. The university has introduced new programmes as per industry requirements like – Post Graduate Diploma in Industrial Safety, Post Graduate Diploma in Hospital Management for government doctors, Post Graduate Diploma in Drug Discovery, Vocational Degree Courses Fashion Design & Management and also in Tourism and Hospitality Management. For female students, the Women Cell of the university regularly conduct seminars / special programs.

1.1.2 Does the university follow a systematic process in the design and development of the curriculum? If yes, give details of the process (need assessment, feedback, etc.).

Yes, the university follows a systematic process in the design and development of curriculum. There is a Board of Studies for every programme offered in the university. The curriculum development process is generally done through Board of Studies. The university invites external experts from Industry, Research Organizations, and Eminent Academician and co-opts them as members of Board of Studies. Suggestions from the senior faculty members and feedback from students are also invited for the modifications/development of the curriculum. Also University Industry meets are organized by University–Industry Linkage Cell to elicit feedback from Industry

regarding curricula and their suggestions are incorporated in the syllabus. The syllabus thus prepared by the Board of Studies is approved by the Academic Council of the University which is then implemented.

1.1.3 How are the following aspects ensured through curriculum design and development?

*** Employability * Innovation * Research**

Employability

The Employability is ensured by the University through following measures like Block Placement by Department of Social Work (M.S.W), Summer Internship by Department of Commerce & Management, Department of Hospital Management, Final Internship by Department of Hospital Management, Project implementation & Employability by Department of Life Sciences, Industrial Project and Training under P.G. Diploma in Industrial Safety Programme at Department of Life Sciences.

Innovation

The curriculum is design and developed keeping in mind the latest Innovations in the respective fields.

Research

The Curriculum is developed taking into account the current research requirement of the market and foster research attributes among the student.

1.1.4 To what extent does the university use the guidelines of the regulatory bodies for developing and/or restructuring the curricula? Has the university been instrumental in leading any curricular reform which has created a national impact?

The State Academic Regulatory Authority KCG (Knowledge Consortium of Gujarat) has taken initiative for reformation in curriculum to be implemented commonly in the state colleges at graduate level. University faculties have actively participated in the development of these curricula and they have also been asked to prepare study material for the same. The uniform curriculum would help the student for inter university transfer along with the Credit.

1.1.5 Does the university interact with industry, research bodies and the civil society in the curriculum revision process? If so, how has the university benefited through interactions with the stakeholders?

Yes, University –Industry Linkage Cell organizes meeting with industry and research bodies to get feedback and to know latest trend in industry and research. The Board of Studies in the respective subject invites the outside experts from Industry, Research Organization, and Eminent Academician and co-opts them as members. Also suggestions from the senior faculty members, Researcher, Academician and feedback from students are considered and discussed in the Board of Studies for the modifications/development of the curriculum. This helps the university in developing syllabus which caters to current requirement of the industry in particular and society as a whole.

1.1.6 Give details of how the university facilitates the introduction of new programmes of studies in its affiliated colleges.

The University facilitates the introduction of new programmes of studies in its affiliated colleges like B.A in Acting, M.A. in Direction, Scriptwriting, Motion Picture Photography, Audiography, Editing, Production Design and Production Management at City Pulse Institute of Film & Television, Gandhinagar, B.A. in Fine Arts (Music, Drama and Painting) at Banaskantha District, Kelvani Mandal Sanchalit Arts & Fine Arts College, Palanpur.

1.1.7 Does the university encourage its colleges to provide additional Skill- oriented programmes relevant to regional needs? Cite Instances (not applicable for unitary universities).

Skill oriented programmes relevant to regional needs are encouraged by the University like Certificate courses in Functional & Communicative English/ Spoken English/ Tourism Studies and Desk Top Publishing (DTP). Programmes like B.R.S and M.R.S in Rural Studies are also offered under the category of skill oriented Programme. The University facilitates skill oriented courses as per the guidelines of Ministry of Human Resource and Development, Government of India.

1.2 Academic Flexibility

1.2.1 Furnish the inventory for the following:

Programmes taught on campus

(i) Grant In Aid Programmes offered by the Departments:

Sr. No.	Department	Programmes
1	Department of Chemistry	M. Sc (Organic, Inorganic,

		physical Chemistry),
2	Department of Commerce & Management	M.B.A.
3	Department of English	M. A.
4	Department of Hospital Management	M.H.M., P.G.D.H.M.
5	Department of Life Science	M. Sc. (Microbiology, Botany, Environmental Science),
6	Department of Mathematics	M.Sc.
7	Department of Sanskrit & Bhartiya Vidhya	M.A., M. Phil., Post Graduate Diploma in Prakrit & Apbhransh.
8	Institute of Architecture	B. Arch.

(ii) Self Financed Programmes offered by the Departments of the University

Sr. No.	Department	Programmes
1	Department of Chemistry	P.G.D. in Drug Discovery & Drug Dev. M.Phil
2	Department of Commerce & Management	M.Com., M.Phil. (Commerce)
3	Department of Computer Science	M.C.A., M.Sc.(CA & IT), MCA(Five Yr. Integrated), PGDCA
4	Department of Education	M.Ed., M.A., M.Phil.
5	Department of English	M.Phil.
6	Department of Journalism & Mass Communication	M.J.M.C., M.Phil.
7	Department of Law	L.L.M., M.Phil.
8	Department of Library & Information Science	B.Lib., M.Lib.
9	Department of Life Sciences	P.G.D. in Industrial Safety & Env. Mgt., P.G.D.M.L.T., M.Phil.
10	Department of Biotechnology	M.Sc., M.Phil.
11	Department of Physical Education	B.P.Ed., M.P.Ed., M.Phil., Dip. In Yoga Education, P.G.D. in Yoga Education
12	S. K. College of Business Management	B.B.A., B.Com., B.Voc. (Fashion Design & Management, Tourism & Hospitality Management), Advance Diploma (Tourism Management, Banking & Insurance, Financial Services, Mobile Communication)
13	Department of Pharmaceutical Science	M. Pharm
14	Department of Physics	M.Sc. (Physics, Electronics)
15	Department of Social Work	B.S.W., M.S.W.
16	Institute of Architecture	M.Urban Planning., M.Design Education

17	UGC Area Study Centre for Indian Diaspora and Cultural Studies	M.Phil.
18	Jain Academy Educational Research Centre	Certificate in Jainology, Diploma in Jainology

All Ph.D. Courses are granted. Faculty wise subjects available for Ph.D. programme are as follow:

Sr. No.	Faculty	Subjects
1	Arts	Economics, English, Journalism, Gujarati, Hindi, History, Home Science, Library & Information Science, Political Science, Psychology, Sanskrit, Social Work, Sociology, Indian Diaspora and Cultural Studies
2	Commerce	Accountancy, Commerce
3	Science	Botany, Chemistry, Environment Science, Life Science, Mathematics, Micro Biology, Zoology
4	Management	Management, Computer Science & Application
5	Education	Education, Physical Education
6	Law	Law
7	Engineering	Mechanical Engineering
8	Medicine	Homeopathy
9	Pharmacy	Pharmacy

No Overseas programmes is offered on campus

* Programmes available for colleges to choose from

Sr. No.	Faculty	Sr. No.	Programme	Subject
1	2	3	4	5
1	Arts	1	Bachelor of Arts	Gujarati, Hindi, Sanskrit, English, History, Psychology, Sociology, Political Science, Economics, Home Science, Geography, Philosophy, - Prakrit, Defense Studies

		2	Master of Arts	Gujarati, Hindi, Sanskrit, English, History, Psychology, Sociology, Political Science, Economics, Home Science.
		3	Bachelor in Social Work	Social Work
		4	Master in Social Work	Social Work
		5	Bachelor of Journalism	Journalism
		6	Master of Journalism	Journalism
		7	B.A.- Fine Arts	Music, Drama, Painting
		8	Bachelor in Library Science	Library Science
		9	Master in Library Science	Library Science
		10	Master in Tourism Studies(MTS)	Tourism Studies
		11	P.G. Diploma in Tourism Studies (PGDTS)	Tourism Studies
		12	Certificate in Tourism Studies. (CTS)	Tourism Studies
		13	Tourism Guide Crash Course Studies (TGCS)	Tourism Studies
		14	Diploma in Jainology	Jainology
		15	Certificate Course in Jainology	Jainology
		16	Certificate Course in Prakrit	Prakrit
		17	Certificate Course in Functional & Commutative English	Functional & Commutative English
		18	Certificate Course in Spoken English	Spoken English
		19	Certificate Course in Disaster Management	Disaster Management
2	Commerce	20	B.Com	Account, Statistics, Business Management. (Gujarati & English Medium)
		21	M.Com	Account, Statistics, Business Management. (Gujarati & English Medium)
		22	Advance Diploma	Banking And Insurance
3	Science	23	B.Sc.	Chemistry, Physics, Mathematics, Zoology, Botany, Biotechnology, Microbiology.
		24	M.Sc.	Chemistry, Physics,

				Mathematics, Zoology, Botany, Biotechnology, Microbiology, Electronics, Environment Science.
		25	Post Graduate Diploma	Medical Laboratory Technology, Industrial Safety & Environment Management.
4	Education	26	B.Ed.	Education
		27	M.Ed.	Education
		28	M.A.	Education
		29	B.P.Ed.	Physical Education
		30	M.P.Ed.	Physical Education
		31	P.G.Diploma	Yoga Education
5	Technology Including Engineering	32	Bachelor of Architecture	Architecture
		33	Bachelor of Architecture	Construction Technology
		34	Master in Design Education	Design Education
		35	Master of Urban Planning.	Urban Planning
6	Law	36	LL.B.	Law
		37	LL.M.	Law
7	Medicine	38	Bachelor of Medicine & Bachelor of Surgery (MBBS)	Medicine
		39	Bachelor of Dental Surgery (B.D.S.)	Dental
		40	Master of Dental Surgery(M.D.S.)	Dental
		41	B.Sc	Nursing
		42	B.Sc. (Post Basic)	Nursing
		43	M.Sc.	Nursing
		44	B.H.M.S.	Homoeopathy
		45	M.D.	Homoeopathy
		46	Post Graduate Diploma	Sports Physiotherapy
8	Pharmacy	47	M. Pharm.	Pharmacy
		48	Post Graduate Diploma	Drug Discovery & Development
9	Home Science	49	B. Sc.	Home Science
		50	M. Sc.	Home Science
10	Rural Studies	51	B.R.S.	Rural Farm Management / Home Science
		52	M.R.S.	Rural Studies
11	Management	53	B.B.A.	Management
		54	M.B.A.	Management

	Studies	55	M.H.R.D.	Human Resource Management
		56	B.C.A.	Computer Science
		57	M.C.A.	Computer Science
		58	P.G.D.C.A.	Computer Science
		59	B.Sc.	Computer Application & Information Technology
		60	M.Sc.	Computer Application & Information Technology
		61	M.C.A. (Five Year's Integrated)	Computer Science
		62	M.H.M.	Hospital Management
		63	Advance Diploma	Tourism Management, Banking & Insurance, Financial Services, Mobile Communication
		64	B.Voc.	Fashion Design & Management, Tourism & Hospitality Management
12	Film & Television	65	B.A. (Film & Television)	Acting
		66	M.A. (Film & Television)	Direction, Scriptwriting, Motion picture photography, Audiography, Editing, Production Design, Production Management

1.2.2 Give details on the following provisions with reference to academic flexibility

- a. **Core / Elective options**
- b. **Enrichment courses**
- c. **Courses offered in modular form**

Choice Based Credit system (CBCS) has been introduced by the University from the year 2011 which offers Core courses, Elective courses, and Soft skill courses to students.

The university has started following courses in modular form with assistance from UGC. They are mentioned below:

- (i) Bachelor of Vocational studies in the subject of (a) Fashion Design & Management, and (b) Tourism & Hospitality Management
- (ii) Advance Diploma in the subject of (a) Tourism Management, (b) Banking & Insurance, (c) Financial Services, (d) Mobile Communication

- d. Credit accumulation and transfer facility**
- e. Lateral and vertical mobility within and across programmes, courses and disciplines**

The university provides Credit accumulation, and transfer facility, but does not provide lateral and vertical mobility within and across the programmes, courses and disciplines.

1.2.3 Does the university have an explicit policy and strategy for attracting international students?

The university has an International Cell which develops strategy and policy for attracting international students. The university also has collaborations with

- (a) California State University, San Bernardino, USA
- (b) Georgia South Western State University, USA
- (c) Bio-nut Research Foundation, Netherlands
- (d) University of Groningen, Netherlands
- (e) United State Department of Agriculture, USA
- (f) De Montfort University, UK

1.2.4 Have any courses been developed targeting international students? If so, how successful have they been? If 'no', explain the impediments.

No specific courses have been developed targeting international students. However, the courses like Post Graduate Diploma in Drug Discovery & Development, Industrial Safety and Environment Management, B.Voc. in Fashion Design and Management, Tourism & Hospitality Management can be targeted to attract international students as the syllabi of the program was developed considering the requirement of International students.

1.2.5 Does the university facilitate dual degree and twinning programmes? If yes, give details.

The university does not offer dual degree programme or twinning programme.

1.2.6 Does the university offer self-financing programmes? If yes, list them and indicate if policies regarding admission, fee structure, teacher qualification and salary are at par with the aided programmes?

Yes the university offers self-financed programmes as given below. The admissions, teacher qualification and salary are followed as

per the norms set by the State Government, UGC and other Regulatory Bodies. University's highest body – Executive Council decides the fee structure of the self financed courses. In case of technical courses offered by the affiliated colleges, fee is to be decided on the basis of approval from State Fee Regulatory Committee. Within university campus, the university offers the following self financed programmes:

Sr. No.	Department	Programmes
1	Department of Chemistry	P.G.D. in Drug Discovery & Drug Dev. M.Phil
2	Department of Commerce & Management	M.Com., M.Phil. (Commerce)
3	Department of Computer Science	M.C.A., M.Sc.(CA & IT), MCA(Five Yr. Integrated), PGDCA
4	Department of Education	M.Ed., M.A., M.Phil.
5	Department of English	M.Phil.
6	Department of Journalism & Mass Communication	M.J.M.C., M.Phil.
7	Department of Law	L.L.M., M.Phil.
8	Department of Library & Information Science	B.Lib., M.Lib.
9	Department of Life Sciences	P.G.D. in Industrial Safety & Env. Mgt., P.G.D.M.L.T., M.Phil.
10	Department of Biotechnology	M.Sc.,M.Phil.
11	Department of Physical Education	B.P.Ed., M.P.Ed.,M.Phil., Dip. In Yoga Education, P.G.D. in Yoga Education
12	S. K. College of Business Management	B.B.A., B.Com., B.Voc. (Fashion Design & Management, Tourism & Hospitality Management), Advance Diploma (Tourism Management, Banking & Insurance, Financial Services, Mobile Communication)
13	Department of Pharmaceutical Science	M. Pharm
14	Department of Physics	M.Sc. (Physics, Electronics)
15	Department of Social Work	B.S.W., M.S.W.
16	Institute of Architecture	M.Urban Planning., M.Design Education
17	UGC Area Study Centre for	M.Phil.

	Indian Diaspora and Cultural Studies	
18	Jain Academy Educational Research Centre	Certificate in Jainology, Diploma in Jainology

All the courses that are available to the affiliated colleges as mentioned in the 1.2.1 are also available to affiliated colleges on self financed basis.

1.2.7 Does the university provide the flexibility of bringing together The conventional face-to-face mode and the distance mode of education and allow students to choose and combine the courses they are interested in? If ‘yes,’ give operational details.

The University does not provide the flexibility of bringing together the conventional face-to-face mode and the distance mode of education. There is no provision to choose and combine the courses from face to face mode and distance mode of education.

1.2.8 Has the university adopted the Choice Based Credit System? (CBCS) If yes, for how many programmes? What efforts have been made by the university to encourage the introduction of CBCS in its affiliated colleges?

Choice Based Credit system (CBCS) has been introduced by the University from the year 2011 for all the programmes except professional courses which are prepared as per the guidelines of the respective Professional Council. Before implementing the Choice Based Credit System, the university organized workshops for principals and teachers of colleges and university departments. Then Board of studies in respective discipline made the syllabus for the CBCS which was implemented in phased manner for first year, second year and third year in the respective bachelor degrees and the same was replicated in the master’s degree programmes.

1.2.9 What percentage of programmes offered by the university follow: * Annual system * Semester system * Trimester system

All the Programmes offered by the university follow Semester System.

1.2.10 How does the university promote inter-disciplinary programmes? Name a few programmes and comment on their outcome.

Inter-disciplinary Courses in Biotechnology, Industrial Safety and Environment, Drug Discovery, Indian Diaspora and cultural studies and Journalism and mass communication are offered by the university as per the needs of the learners.

1.3 Curriculum Enrichment

1.3.1 How often is the curriculum of the university reviewed and upgraded for making it socially relevant and/or job oriented / knowledge intensive and meeting the emerging needs of students and other stakeholders?

The curriculum of the university is reviewed and upgraded every three years keeping in mind the relevant changes taking place in various disciplines. Feedback from Students, senior faculty members, Eminent Academicians, Researchers and Industry Experts are taken into consideration for upgrading the curriculum. Industry Academia Interaction is organized to full fill the above objective.

1.3.2 During the last four years, how many new programmes at UG and PG levels were introduced? Give details.

The Following new programmes at UG and PG levels were introduced from June 2009 onwards:

Sr. No.	Faculty	Programme	Subject	Introduce From
1	Arts	U.G.		
		Bachelor in Social Work	Social Work	June - 2010
		Certificate in Tourism Studies (CTS)	Tourism Studies	June - 2013
		Tourism Guide Crash Course Studies (TGCS)	Tourism Studies	June - 2013
		Diploma in Jainology	Jainology	June - 2013
		Certificate Course in Jainology	Jainology	June - 2012
		Certificate Course in Functional & Communicative English	Functional & Communicative English	June - 2012
		Certificate Course in Spoken English	Spoken English	June - 2012
		Certificate Course in Disaster Management	Disaster Management	June - 2013
		P.G.		

		Master in Tourism Studies (MTS)	Tourism Studies	June - 2013
		M.Phil	Physical Education	June - 2011
		M.Phil	Journalism	June - 2011
		P.G. Diploma in Tourism Studies (PGDTS)	Tourism Studies	June - 2013
2	Commerce	U.G.		
		Advance Diploma in Banking And Insurance	Banking And Insurance (Under UGC Scheme)	June - 2013
3	Science	P.G.		
		Post Graduate Diploma in Industrial Safety & Environment.	Industrial Safety & Environment.	June - 2011
4	Education	P.G.		
		P.G. Diploma in Yog Education	Yoga Education	June - 2012
5	Technology Including Engineering	P.G.		
		Master in Design Education	Design Education	June - 2013
		Master in Urban Planning	UrbanPlanning	June - 2013
6	Medicine	U.G.		
		B.Sc. Nursing (Post Basic)	Nursing	June - 2010
		Bachelor of Medicine & Bachelor of Surgery (MBBS)	Medicine	June - 2012
		P.G.		
		M.D. (Homoeopathy)	Homoeopathy	June-2009
		Post Graduate Diploma in Sports Physiotherapy (PGDSP)	Sports Physiotherapy	June - 2010
7	Pharmacy	P.G.		
		M.Pharm	Pharmacy	June - 2011
		Post Graduate Diploma In -Drug Discovery	Drug Discovery	June - 2011

8	Home Science	P.G.		
		M.Sc.-Home Science (Clothing & Textile)	Home Science	June 2013 -
		M.R.S.	Rural Studies	June 2011 -
9	Management Studies	U.G.		
		Advance Diploma in Tourism Management (Under UGC Scheme)	Tourism Management	June 2013 -
		P.G.		
		M.H.R.D.	Management	June 2012 -
		M.C.A. (Five Years Integrated)	Computer Science	June 2013 -
		Master of Hospital Mangt.	Hospital Management	June 2009 -
		Diploma in Desktop Publishing	Computer Science	June 2013 -
10	Film & Television	U.G.		
		B.A. in Acting	Film & Television	June 2009 -
		P.G.		
		M.A. in Direction	Film & Television	June 2009 -
		M.A. in Scriptwriting	Film & Television	June 2009 -
		M.A. in Motion picture photography	Film & Television	June 2009 -
		M.A. in Audiography	Film & Television	June 2009 -
		M.A. in Editing	Film & Television	June 2009 -
		M.A. in Production Design	Film & Television	June 2009 -
		M.A. in Production Management	Film & Television	June 2009 -

1.3.3 What are the strategies adopted for the revision of the existing programmes? What percentage of courses underwent a syllabus revision?

The University has various Academic bodies like Board of Studies, Faculties, BUTR (Board of university teaching and research) and Academic Council through which designing and revision is done.

The Board of Studies regularly reviews the need and scope of revision of syllabus as per the needs and development in the subject pertaining to Society and Industry. These Components are incorporated from time to time and are proposed for implementation.

In the year 2011 new syllabus across all the faculties was introduced as per the requirement of the Choice Based Credit system.

1.3.4 What are the value-added courses offered by the university and how does the university ensure that all students have access to them?

Following value-added courses are offered by the university: Certificate Courses in Functional & Communicative English, Spoken English, Disaster Management, Yoga and Desk Top Publishing (DTP).

1.3.5 Has the university introduced any higher order skill development programmes in consonance with the national requirements as outlined by the national Skills Development Corporation and other agencies?

As far as skill development programme is concerned, the university has introduced following vocational programmes in the year 2014 under the financial assistance from UGC:

- (i) Bachelor of Vocational Degree programme (three year time duration) in the area of Fashion Design and Management
- (ii) Bachelor of Vocational Degree programme (three year time duration) in the area of Tourism and Hospitality Management
- (iii) Advance Diploma programme (two year time duration) in Tourism Management
- (iv) Advance Diploma programme (two year time duration) in Banking & Insurance
- (v) Advance Diploma programme (two year time duration) in Financial Services
- (vi) Advance Diploma programme (two year time duration) in Mobile Communication

The syllabus of above programme was designed to increase employability of candidates or the candidate can start own business also. The respective departments have tied up with several industries to ensure the objective of employability and shaping generating entrepreneurs in the region.

1.4 Feedback System

1.4.1 Does the university have a formal mechanism to obtain feedback from students regarding the curriculum and how is it made use of?

The University has formal mechanism to obtain feedback from students regarding the curriculum. The relevant Component obtained through the feedback are incorporated from time to time and are proposed for implementation.

1.4.2 Does the university elicit feedback on the curriculum from national and international faculty? If yes, specify a few methods such as conducting webinars, workshops, online discussions, etc. and its impact.

The university-industry linkage cell organizes meetings with industry experts to get feedback on their requirement and current trend. The feedback received through this is shared with members of board of studies. Also the university co-opts the members from industry and academician from institute of repute. The board of studies meets twice in a year to discuss on various aspects of the curriculum. Seminars and workshops conducted by the university/departments provide opportunity to interact with national and international faculty on various aspects of curriculum.

1.4.3 Specify the mechanism through which affiliated institutions give feedback on curriculum enrichment and the extent to which it is made use of.

Teachers of the affiliated colleges are free to give their opinion and suggestion on curriculum enrichment to the Chairman of board of studies. Also there is a representation of affiliated college teachers in board of studies. Teachers of affiliated colleges are also helping the board members in preparation of syllabus.

1.4.4 What is the quality sustenance and quality enhancement measures undertaken by the university in ensuring the effective development of the curricula?

The curriculum development process involves various Authorities of the University like Board of Studies, Faculties, and Academic Council to ensure Quality. The Syllabus is prepared by the Board of Studies. The Board invites experts from Industry, Research

Organization, and Eminent Academicians and co-opts them as members. Also suggestions from the senior faculty members and feedback from students are invited for the modifications/development of the curriculum. Also the University and Industry meets are organized by University –Industry Linkage Cell to elicit feedback from Industry regarding curriculums and their suggestions are incorporated in the syllabus.

CRITERION II: TEACHING-LEARNING AND EVALUATION

2.1 Student Enrolment and Profile

2.1.1 How does the university ensure publicity and transparency in the admission process?

- ✓ By publishing advertisement for admission in state level as well as local newspapers.
- ✓ By displaying notice of admission on university website.
- ✓ By providing online admission process.

Sr.	Type of admission process	Progemme Covered	Name of co-ordinator & Committee
1.	University Centralized Admission	B.Ed., M.Ed.	Dr. S.G. Patel
2.	University Centralized Admission	M.Sc. CA & IT	Shri Dilipbhai J. Chaudhary
3.	University Centralized Admission	BRS, MRS, BSW,MSW	Dr. Himmatsinh Rajput
4.	University Centralized Admission	M.sc.	Dr. M.B. Prajapati

disadvantaged backgrounds & empowering the SC & ST students with remedial coaching.

- ✓ The university has a separate SC/ST Cell to increase/improve access for students. Each department of university facilitates such students obtaining The UGC and State Government rules are strictly followed for reserving seats for SEBC, SC, ST, Ex-servicemen, widows and physically challenged students.
- ✓ Online merit based admission process is followed.

2.1.2 Explain in detail the process of admission put in place by the university. List the criteria for admission: (e.g.: (i) merit, (ii) merit with entrance test, (iii) merit, entrance test and interview, (iv) common entrance test conducted by state agencies and national agencies (v) other criteria followed by the university (please specify).

- ✓ For Colleges (UG): Based on H.S.C. merit
- ✓ For masters (PG): Based on Bachelors merit and/or entrance exams
- ✓ For M.Phil.: Based on merit as well as entrance test as per UGC regulation 2009
- ✓ For Ph.D.: Based on entrance test followed by interview as per UGC regulation 2009

- ✓ NCC “C” certificate holders are given extra 10 marks in the merit.
- ✓ Fresh students are given preference. Three marks are deducted for each year if a student did not enroll for any course in between his/her last degree.

2.1.3 Provide details of admission process in the affiliated colleges and the university’s role in monitoring the same.

- ✓ Online enrollment process for affiliated colleges for student enrollment
- ✓ Online process done on Universities own website under the supervision of University authorities.
- ✓ Admission committee formed by University for any grievance’s in admission of UG course
- ✓ All the relevant UGC rules are strictly followed.

2.1.4 Does the university have a mechanism to review its admission process and student profile annually? If yes, what is the outcome of such an analysis and how has it contributed to the improvement of the process?

Every faculty has an Admission Committee which periodically reviews the admission process and student profile, and suggests measures to improve the same. Further, changes to admission criteria, modalities, and so on are suggested by the university’s Executive Council as and when necessary. Feedback from students is reviewed and suggestions incorporated whenever possible.

2.1.5 What are the strategies adopted to increase / improve access for students belonging to the following categories:

- * SC/ST
- * OBC
- * Women
- * Persons with varied disabilities
- * Economically weaker sections
- * Outstanding achievers in sports and other extracurricular activities

The university adheres strictly to government regulations regarding admission of students from SC/ST and other disadvantaged backgrounds. Special reservations earmarked for various disadvantaged communities and weaker sections of the society. The prospectus given to the aspirants elaborate the various tuition fee concessions and exam fee concessions extended by the government to the disadvantaged communities and economically weaker sections of society.

There are provisions for remedial coaching of students from scholarships from the Government, helping in getting educational loans from banks and the Government as well as non-governmental agencies.

NCC “C” certificate holders are given extra 10 marks in the merit.

2.1.6 Number of students admitted in university in the last four academic years:

Categories	2010-11		2011-12		2012-13		2013-14	
	Male	Female	Male	Female	Male	Female	Male	Female
SC	7252	5133	8873	10756	7758	6415	11282	8497
ST	4034	2990	4264	4874	4580	3535	5967	5283
OBC	24755	14467	28325	35975	21616	17776	37782	22157
General	27961	26711	25343	25385	25808	25323	24173	24528
Total	64002	49301	66803	76990	59762	53049	79204	60465

Course	Year. 2010-11	Year. 2011-12	Year. 2012-13	Year.2013-14
UG	102098	109338	125011	125146
PG	8864	7894	9917	12704
M.Phil	42	96	307	271
Ph.D	69	70	107	156
Diploma	10	27	17	15
PG Diploma	1401	996	740	671
Integrated Masters	726	658	643	706
Certificate	-	-	-	-
Integrated Ph.D	-	-	-	-
Other	-	-	-	-

2.1.7 Has the university conducted any analysis of demand ratio for the various programmes of the university departments and affiliated colleges? If so, highlight the significant trends explaining the reasons for increase / decrease.

The University before introducing new course/giving new affiliation for a course in the existing institution/new institution, refer the matter to the NEED committee established by the Executive committee of

the university.

The NEED COMMITTEE members deliberate on all the issues and recommend the university whether new course to be introduced/ affiliation to given to existing institution/new institution considering demand ratio, future of the course, available intake in the area, etc.

In the academic year 2014-15, the NEED COMMITTEE has recommended the following courses to the institution as given in the table below

Sr. No	Name of the Institution	Course for which NOC is issued
1	Merchant Charitable Trust, Visnagar	B.H.M.S (Homeopathy)
2	Shree Satsangi Saketdham Ashram, Vadsma	B.Physiotherapy
3	Vadu Juth Kelavni Mandal, Vadu	B. Architecture & Design
4	Gokul Foundation, Siddhpur	B. Physiotherapy
		B. Nursing
		5 year Law Integrated
5	Merchant Charitable Trust, Basna	M.B.B.S, B.H.M.S
6	Banaskantha Dist. Kelavni Mandal,	5 year Law Integrated

2.1.8 Were any programmes discontinued /staggered by the university in the last four years? If yes, please specify the reasons.

No programme has been discontinued in the last four years

2.2 Catering to Student Diversity

2.2.1 Does the university organize orientation / induction programme for fresher? If yes, give details such as the duration, issues covered, experts involved and mechanism for using the feedback in subsequent years.

- ✓ The freshers are given opportunity to interact with senior students and teachers at the beginning of the semester.
- ✓ Various Departments organise welcome parties for freshers
- ✓ Expert lectures in various Departments for brushing up the subject by internal and external faculties

2.2.2 Does the university have a mechanism through which the “differential requirements of the student population” are

analyzed after admission and before the commencement of classes? If so, how are the key issues identified and addressed?

- ✓ Forming groups of students according to their grasping abilities
- ✓ Various committees are formed among students i.e., Sports committee, Cultural committee, Laboratories in-charge, Cleaning committee, Notice board in-charge, Instrumentation maintenance committee etc.
- ✓ For slower grasping students additional evening classes been taken
- ✓ For the students with having stage fever, class seminar been arranged for them

2.2.3 Does the university offer bridge / remedial / add-on courses? If yes, how are they structured into the time table? Give details of the courses offered, department-wise/faculty-wise?

Yes, University offers remedial coaching classes for SC/ST/OBC/Minorities. The remedial coaching is not department wise but it is done centralized in the university. Following table shows detail of it:

Name of coordinator	Name of Scheme
Dr.(Mrs.) Kokilaben A. Parmar Associate Professor, Dept. of Chemistry	Remedial Coaching Classes at UG-PG Level for SC-ST-OBC- Minorities.

However, brilliant students of the departments also some time conduct remedial coaching of the weak students and help them.

Details of Courses offered, Department-wise/Faculty-wise

Sr.	Name of the Department	Programme Name/ Duration	Eligibility	Intake
1.	Department of Sanskrit And Bhartiya Vidya	MA (Sanskrit) 2 years	BA (Sanskrit)	80 (GIA)
2.	Department of English	MA (English) 2 years	BA (English)	80 (GIA)
3.	Department of Commerce And Management	M.BA 2 years	As per AICTE/State government /University norms	60 (GIA)
4.	Department of Hospital	M. H. M 2 years	Graduates in Medical & Para	40 (GIA)

	Management		Medical including Bio-Medical Engineering. BSC (Biotech) and Master Degree in Medical Science subject (Microbiology, Biochemistry) with 50% marks.	
5.	S. K. College of Business Management	B. B. A. 3 years	12 science with English	120 (SF)
6.	Department of Pharmaceutical Science	M. Pharm Pharmaceutics QA Pharma Management & Regulatory affairs 2 years	As per GPAT/PGSET/B. Pharm norms	54 (SF)
7. 8.	Department of Computer Sciences	MSC CA & IT 5 years	12 pass with English and any one subject of following (1) Maths (2) Statistics (3)Account(4) Business Maths (5) Physics (6)Computer	170 (SF)
		M.C. A. 3 years	As per GCET norms	60 (SF)
9.	R. J. Computer Center	PGDCA 1 year	Any Graduate	60 (SF)
10.	Department Library And Information Science	B. Lib & Information Sciences 1 year	Any Graduate	50 (SF)
		M. Lib & Information Sciences 1 year	B lib	50 (SF)
11.	Department of Social Work	B. S. W. 3 years	12 pass	35 (SF)
		M. S. W. 2 years	Any Graduate	60 (SF)
12.	Department of Physical	B. P. Ed 1year	Graduate with sports background	50 (SF)

	Education	M. P. Ed 2 years	B. P. Ed	30 (SF)
13.	Department of Education	M. Ed. 1 year	B. Ed.	70 (SF)
14.	Department of Law	LLM Business Law Criminal Law 1 year	Second LLB	60 (SF)
		Diploma in Human Rights Environmental Law Legislative writing 1 year	Second LLB	60 (SF)
15.	Department of Journalism And Mass Communication	M.J. M.C. 1 year	Any graduate	20 (SF)
		DTP Six Months	Any graduate	20 (SF)
16.	Department of Chemistry * Subjected To University Approval	MSC (Chemistry) 2 years	BSC(Chemistry)	55 (GIA) * 45 (SF)
		PG Dip. in Drug Discovery 1 year	BSC(Chemistry)	25 (SF)
17.	Department of Life Sciences	MSC (Microbiology) 2 years	BSC(Microbiology)	30 (GIA)
		MSC (Botany) 2 years	BSC(Botany)	15 (GIA)
		MSC (Environ. Science) 2 years	BSC degree in any Science Subject	15 (GIA)
		PG Diploma in laboratory technology 1 year	BSC Life sciences and chemistry	20 (SF)
		PGIS 1 year	BSC degree in any Science Subject	15 (SF)
18.	Department of Biotechnology	MSC(Biotechnology) 2 years	Graduation in any Biological Sciences	30 (SF)
19.	Department of Mathematics	MSC (Mathematics) 2 years	BSC(Mathematics)	60 (GIA)
20.	Department of Physics	MSC (Physics) 2 years	BSC(Physics)	30 (SF)

		MSC (Electronics) 2 years	BSC(Physics)	20 (SF)
21.	Institute of Architect	B. Arch 5 Years	Minimum 50% in HSC with Maths and NATA with 48%	40 (GIA)
22.	Yoga Centre	PG Dip. in Yoga Vocational Diploma in Yoga 1 year	Any Graduate 12th Pass	30 30
23.	M. Phil. In Sanskrit (1 year)		Master Degree with 55% (SC, ST - 50%)	20 (GIA)
24.	M.Phil Programmes M. Phil. In Chemistry (1 year) M. Phil. In Life Sciences (1 year) M. Phil. In Commerce(1 year) M. Phil. In Indian Diaspora(1 year) M. Phil. In Economics (1 year) M. Phil. In Education (1 year) M. Phil. In English (1 year) M. Phil. In Gujarati (1 year) M. Phil. In Hindi (1 year) M. Phil. In History (1 year) M. Phil. In Journalism (1 year) M. Phil. In Law, (1 year) M. Phil. In Physical Education (1 year) M. Phil. In Biotechnology(1 year) M. Phil. In Sociology(1 year)		Master Degree with 55% (SC, ST - 50%)	20 In each subject (SF)
25	Ph. D. Ph. D. In Biotechnology, Botany, Chemistry, Commerce, Computer Science, Economics, Education, English, Environmental Science, Gujarati, Hindi, History, Home Sciences, Journalism And Mass Communication, Law, Library And Information Science, Management, Microbiology, Pharmacy, Physical Education, Psychology, Sanskrit, Sociology, Zoology and Indian Diaspora			

2.2.4 Has the university conducted any study on the academic growth of students from disadvantaged sections of society, economically disadvantaged, physically handicapped, slow learners, etc.? If yes, what are the main findings?

The systematic study on the progress of the disadvantaged students is yet to be undertaken. The university offers following four

programs for the empowerment of such category of students. They are

Sr. No.	Name of Scheme
1	Remedial Coaching Classes at UG-PG Level for SC-ST-OBC-Minorities.
2	OBC- Non Creamy layer Coaching classes for Entry in Service.
3	Remedial Coaching Classes at NET/ GSET for SC-ST-OBC-Minorities.
4	Equal Opportunity Cell

2.2.5 How does the university identify and respond to the learning needs of advanced learners?

- ✓ Talented students are sent to national institutes for training where more resource is available.
- ✓ Encouraging students to take part in seminars, conferences etc... where they can interact with the subject experts and sharpen their knowledge.
- ✓ Various university departments conduct educational tour to national and state level institutes.
- ✓ Many of our Department arranges guest lectures series by inviting subject experts, under the UGC scheme.

2.3 Teaching-Learning Process

2.3.1 How does the university plan and organise the teaching, learning and evaluation schedules (academic calendar, teaching plan, evaluation blue print, etc.)?

Academic calendar is produced by University following UGC pattern. The academic calendar of for the year 2013-2014 is shown below:

Sr .	Particulars	Date as per academic calendar
1.	Beginning of the Academic Year	15-06-2013
2.	Date of Completion of the Admission -- Under Graduate -- Post Graduate Departments / Centers	22-06-2013
3.	Commencement of Teaching Work -- Colleges I Department -- Semester I & III & V	24-06-2013 to 27-06-2013

4.	Last Date of Submission of P.G. Registration forms to the University * Last Date of Submission of the First Year Under Graduate Enrolment forms	14-08-2013
5.	Internal Test	End of the Exam to 28-10-2013
6.	End of the First Term	31-10-2013
7.	University Examination (October-December) (ATKT) (Semester-I-III & V all exam. of CBCS)	14-10-2013 to 30-10-2013 25-11-2013
8.	Diwali Vacation	01-11-2013 to 21-11-2013
9.	Beginning of the Second Term (Sem. II & VI) (Sem. IV) - Beginning of A.T.	22-11-2013 09-12-2013
10.	Internal Test (Preliminary Examination) Colleges / Rural Studies	15-03-2014 Examination End
11.	University Examination (March-April) Without CBCS CBCS	03-03-2014 24-03-2014
12.	End of the Second Term Colleges Department	26-04-2014
13.	Summer Vacation	27-04-2014 to 14-06-2014

- ✓ Workload is allotted as per the UGC rules.
- ✓ Time table is prepared and strictly followed as per UGC norms in all the Departments
- ✓ At department level subject wise session plans are prepared by concerned subject teachers. The session plan provides information related to syllabus, topic to be covered in particular session, list of text book and reference books, list of other related readings, information about projects to be carried out and bifurcation of weightage given to projects/ presentations /quiz/assignments/internal exams/university exam.

2.3.2 Does the university provide course outlines and course schedules prior to the commencement of the academic session? If yes, how is the effectiveness of the process ensured?

Yes, The University website contains all information that a student would require in beginning of the session. The University website also provides the contact numbers and e-mail addresses of all the faculty members so that if any requirement regarding academics arises even at odd hours students may contact the concerned person and get appropriate information. After admission the concerned syllabi, course plans and outlines and various schedules are distributed to the students. The faculty members prepare their class teaching as per the time table and display the same on the departmental notice boards. Academic council updates syllabus as per need on a regular basis. Google/Yahoo groups have been created for dissemination of notices/instructions/notes etc.

2.3.3 Does the university face any challenges in completing the curriculum within the stipulated time frame and calendar? If yes, elaborate on the challenges encountered and the institutional measures to overcome these.

Almost all the courses are completed on time by the University departments. Even the extra lectures are arranged during Holidays or evening/morning time as per needs.

2.3.4 How is learning made student-centric? Give a list of participatory learning activities adopted by the faculty that contributes to holistic development and improved student learning, besides facilitating life-long learning and knowledge management.

Courses are modified as per current need of industries as well as academia. Besides using Power Point Presentation and ICT based lectures, group discussions, case studies and role plays are also used. Assigning project work enables students to develop advanced skills.

For all round development, students are assigned Laboratory work / Practical exercises, Field visits, Group discussions / Seminar Assignments based on Lab work/ Fieldwork, Visit to industries / institutes, Study tour and Power-point presentations and other ICT based programmes.

The classroom lectures are supplemented with audio visual aids especially in the form of PowerPoint presentations along with traditional black board module. In addition to this web-based learning, online lectures, and popular lectures are appended by the faculty and experts from other agencies to enrich the knowledge content. Assistance is given to the students for effective presentations in seminar sessions.

2.3.5 What is the university's policy on inviting experts / people of eminence to deliver lectures and/or organize seminars for students?

Experienced and renowned visiting faculties are invited regularly to complement the permanent and guest faculty to complete the courses as well as to share their research and teaching experiences with students. For this, at the Departmental level a list of renowned persons to be invited is prepared. The list is approved by the Vice Chancellor and depending upon the slots available in the time-table, the Visiting faculty is invited. During such lectures by visiting faculties, specialized requirements are identified from the students' feedback and are used to plan for future sessions. Another round of feedback is taken as to how such sessions have improvised the overall academic quality within the students.

Subject experts are invited from all over India for enrichment of students. Online lectures are arranged with international scientists. NPTEL and other lecture series are also conducted.

2.3.6 Does the university formally encourage blended learning by using e-learning resources?

Yes, the University departments have 24x7 Internet access and are connected with high-speed broadband facility. Many of our departments have Wi-Fi facility. Students are always encouraged to take tutorials in electronic form and are also advised to refer to the Goggle Search / Scopus for appropriate Journals and review papers. Multimedia based lectures are part and parcel of almost all the Departments.

DELNET subscription is available to university departments.

E-library has been created in various science Departments, students are also shown Online lectures delivered by national as well as international experts.

2.3.7 What are the technologies and facilities such as virtual laboratories, e-learning, open educational resources and mobile education used by the faculty for effective teaching?

The following technologies and facilities are used by the faculty for effective teaching:

- The ICT based teaching-learning aids such as – Multimedia projectors with latest technology are used for teaching in all Schools/Institutes.
- Well-furnished Computer Laboratories with Internet connectivity.
- An Internet connectivity of 1 Gbps under National Knowledge Network (NKN) Project of MHRD is under progress. In some of the departments Wi-Fi facility has also been made available.
- The e-resources, e-books and database are available through

INFLIBNET-UGC-Infonet Digital Library Consortium for regular access to the faculty members of the University.

- The DELNET subscription provides access to the e-books, database and other e-learning resources to the faculty. University has membership of BRITISH LIBRARY (www.britishcouncilonline.org) & Bentham (<http://ingentaconnect.com/content/ben>). The Departments are provided with the internet connectivity to access online lectures/videos.
- A Language laboratory with full internet access has been established in the Department of English which is utilized to conduct the classes for the improvement of communication and soft skills of the students.
- Virtual labs for applied subjects like Bioinformatics are available.

2.3.8 Is there any designated group among the faculty to monitor the trends and issues regarding developments in Open Source Community and integrate its benefits in the university's educational processes?

There is no separate designated group of faculty to monitor the trends and issues regarding developments of Open Source Community in the University. However, the Department of Computer Sciences monitors the trends and issues regarding the developments in open source technologies.

Latest open source technologies are included in curricula of University wherein the courses like - PHP, JAVA, UNIX-Linux Programming, MYSQL etc. are introduced to integrate its benefits in the University's educational processes. Informally, the Staff of various departments monitors trends and issues regarding the developments in the open source community *e.g.* Google Group, Moodle etc. — executing its benefits in the educational processes at various departments.

2.3.9 What steps has the university taken to orient traditional classrooms into 24x7 learning places?

Our Science Department labs are open to 24X7 almost throughout the year, Central library is normally open almost for 12 hours, students can pose their queries anytime by contacting the faculty on their personal numbers, and Assignments are given to students as internal evaluation strategy.

Class seminars are arranged for which students learn at home and make presentations, Soft Skill courses are offered as per need of students.

2.3.10 Is there a provision for the services of counsellors / mentors/ advisors for each class or group of students for academic, personal and psycho-social guidance? If yes, give details of the

process and the number of students who have benefitted.

The Heads/Faculties counsel the students on academic and personal problems, career opportunities and try to make them aware of their strong points and weaknesses from time to time. As such, there is no formal provision for the services of counselors/mentors/advisors for each class or group of students for academic, personal and psycho-social guidance. But university has a special chair (Smt. Vidyaben Deepchandbhai Gardi Chair) which is acting as counselors/mentors/advisors to university students helping them in the following areas:

- To Shape, sensitize and inculcate competitive approach in students.
- To equip students with knowledge and skill for higher education, research, job and administrative career building.
- To stimulate entrepreneurship passion.
- To integrate existing resources for career building.
- To find new sources in inherent assets for sustainable development.

2.3.11 Were any innovative teaching approaches/methods/practices adopted/put to use by the faculty during the last four years? If yes, did they improve learning? What were the methods used to evaluate the impact of such practices? What are the efforts made by the institution in giving the faculty due recognition for innovation in teaching?

In the last five years, many teachers have developed ICT enabled course material. Such material is accessed by students using Google groups and yahoo groups. Many departments are supplied with audio visual teaching aids which are also used to teach students.

Learner centric activities like participative learning, interactive sessions, students' seminars, case studies, project work, assignments, problem solving exercises and field work are used.

In most of the departments, a hierarchy is created from most senior Ph. D. scholars to the junior level master students to pass on several learning practices, experimental skills, computational skills, instrumentation training, and writing research papers, preparing posters, accessing journals/research materials, funding applications, etc. Excellent results and outputs are observed in terms of knowledge, imparting training, extension and generating revenues.

The significant teaching-innovations made in the last five years are mentioned below:

Practical work: Nearly half of the total academic work time is devoted to practical/project work aimed at creating industry like work environments.

Case method: Students are assigned live projects as case studies that

are aimed at testing the application of theoretical concepts to industry situations.

Feedback: Both teachers and students evaluate each other with the mutual enrichment so that excellence can be promoted.

Personality development initiatives: Students are divided into groups to work on projects and make classroom presentations to foster team spirit and sharing of knowledge.

2.3.12 How does the university create a culture of instilling and nurturing creativity and scientific temper among the learners?

To nurture critical thinking, creativity and scientific temper among students, various activities like debate, extempore speaking, essay competition, seminars, group discussions, symposia, poster presentations, field survey, making models and practical exercises of curriculum are conducted from time to time, Different Science day celebrations, Industrial visit for better understanding of practical approach, Motivating students for competitive examination, Inspiring students for writing scientific article is also undertaken.

2.3.13 Does the university consider student projects mandatory in the learning programme? If yes, for how many programmes have they been (percentage of total) made mandatory?

* Number of projects executed within the university

Project work for students is mandatory in many of the departments under the CBCS of the University pursuing their UG/PG programmes. Students usually undertake projects with industrial and commercial organizations. Faculties actively involve themselves in facilitating the completion of project work. The duration of the project work is either one Semester or done during summer vacation.

* Names of external institutions associated with the university for student project work

Faculty from departments and the students decide the title and type of their project work. Below are few external institutes where students carry out their project work

1. Gujarat state biotechnology mission (GSBTM)
2. Abellon clean energy company
3. Gujarat Cancer research institute
4. Junagadh Agricultural University
5. Anand Agricultural University
6. Sardar Krushinagar Dantiwada Agricultural University
7. Civil Hospital, Ahmedabad IVF Facility
8. National Rural Health Mission, Government of Gujarat

9. Many Private sector companies, etc...

* Role of faculty in facilitating such projects

The faculty members' role is very much important; students' project work is carried out under the guidance of the faculty members. The faculty's role begins from the title finalization, and continues till the final report writing by students. Student's projects are a part of their internal evaluation in the various departments at the UG/PG level. Each student works under the supervision of a faculty member for their dissertation and other research works.

2.3.14 Does the university have a well qualified pool of human resource to meet the requirements of the curriculum? If there is a shortfall, how is it supplemented?

Yes, the university has a well qualified pool of human resources to meet the requirements of the curriculum.

The number of seats vacant in grantable departments due to state government policy, the university has taken the initiative of appointing qualified contractual staff.

For self-finance programmes, university takes care to appoint qualified staff as per the norms.

2.3.15 How are the faculty enabled to prepare computer-aided teaching/ learning materials? What are the facilities available in the university for such efforts?

All the faculty members have independent computers as well as laptops with internet facilities. The facility of computer labs is available in many departments; almost all departments have LCD projectors for power point presentation. The Central Library too offers modern technological services to teachers.

E-Journal available for Faculties for research work or preparing their lecture notes:

Journal of American Chemical Society, American Institute of Physics, American Physical Society, Annual Reviews, Blackwell Publishing, Cambridge University Press, Emerald, Institute of Physics, JCCC, Oxford University Press, Project Muse, Royal Society of Chemistry, Springer Link, Taylor and Francis are made freely available to the teachers .

The library has installed LAN using SOUL software for e-resources. INFLIBNET support has also been provided.

Free membership of BRITISH LIBRARY, DELNET (DELNET ONLINE), INFLIBNET CENTRE, Bentham is available to the teachers.

2.3.16 Does the university have a mechanism for the evaluation of teachers by the students / alumni? If yes, how is the evaluation feedback used to improve the quality of the teaching-learning process?

Student feedback from duly filled up by the learners is taken at the end of each year. Faculty feedback form has also been implemented recently relevant suggestions given by the students in feedback forms are incorporated by the faculty.

With the help of feedback received from the students, faculty members constantly try to make their classroom teaching effective.

Feedback from student about university teachers		
Question ID	Question	Ranking
1.	Class Taking Ratio As Per Time Table	3.10
2.	Command On Language	3.27
3.	Completion Of Syllabus	2.57
4.	Internal Testing System	1.82
5.	Teaching Power	3.25
6.	Study Material Provided	1.43
7.	Quality Of Study Material	3.68
8.	Support In Co-Curricular Activity	2.17
9.	Support In Practical Work	2.35
10.	Support In Preparation For Conference Seminar Small Projects	1.12

2.4 Teacher Quality

2.4.1 How does the university plan and manage its human resources to meet the changing requirements of the curriculum?

The teachers are required to submit Self Appraisal Report (SAR) every year. On the basis of the SAR of a teacher, his/her teaching and research performance is judged. The teachers are compulsorily required to update their knowledge through refresher / orientation courses conducted by Academic Staff Colleges. Besides, on the teachers' request they are also sent for special training programs to various International, National, State universities or

institutes. However, the SAR keeps teachers on their toes with a complete assessment of their teaching, research contribution, extension work and participation in corporate life and innovation in teaching and curriculum update.

Continuous exposure to recent trends in research, teaching is also gained by participation in national and international seminars / conferences.

Faculty members of all departments are required not only to participate in conferences / seminars but also organize seminars / conferences during which they get ample exposure and knowledge of new trends and changes.

2.4.2 Furnish details of the faculty

Qualifications of the teaching staff (Grant-in-Aid Programmes)

Highest Qualification	Professor		Associate Professor		Assistant Professor		Total
	Male	Female	Male	Female	Male	Female	
Permanent teachers							
D.Sc./D.Litt.							
Ph.D.	08	02	04	01	06	03	24
M.Phil.							
PG			01		01		02
Temporary teachers							
Ph.D.						01	01
M.Phil.					01	06	07
PG					05	04	09
Part-time teachers							
Ph.D.							
M.Phil.							
PG							

Qualifications of the teaching staff (Self Financed Programmes)

Highest Qualification	Professor		Associate Professor		Assistant Professor		Total
	Male	Female	Male	Female	Male	Female	
Permanent teachers							
D.Sc./D.Litt.							
Ph.D.	01			01	12	06	20
M.Phil.							
PG					10	03	13
Temporary teachers							
Ph.D.							

Highest Qualification	Professor		Associate Professor		Assistant Professor		Total
	Male	Female	Male	Female	Male	Female	
M.Phil.							
PG							
Part-time teachers							
Ph.D.					01	01	02
M.Phil.						01	01
PG					01	04	05

2.4.3 Does the university encourage diversity in its faculty recruitment? Provide the following details (department / school-wise).

Yes, few of our departments have faculty from out state

Department / School	% of faculty from the same university	% of faculty from other universities within the State	% of faculty from other universities outside the State	% of faculty from other countries
Department of Hospital management	40	-	60	-
Department of English	33	-	67	-
Department of Chemistry	-	50	50	-

2.4.4 How does the university ensure that qualified faculty is appointed for new programmes / emerging areas of study (Bio-technology, Bio-informatics, Material Science, Nanotechnology, Comparative Media Studies, Diaspora Studies, Forensic Computing, Educational Leadership, etc.)? How many faculty members were appointed to teach new programmes during the last four years?

University has started new programs viz. Department of Hospital Management, Vocational programs (B.Voc), Community College (Advance Diploma), Career Oriented courses (Advance Diploma), Post Graduate diploma in Industrial Safety.

While introducing a new program, university keeps in mind the teaching requirements and appointments are made following the UGC guidelines.

To attract the suitable candidates, the advertisements are published in National level newspapers and put on the website of the university.

After receiving the applications further processing is done and the selection committee is formed.

The number of teachers selected for newly started courses in last four years is as follows:

Year	Course	Teacher Appointed
2009	Department of Hospital Management	3
	Post Graduate Diploma in industrial Safety	Visiting Faculty
2013-14	B.Voc (Fashion Design and management)	As per UGC Guideline
2013-14	B.Voc (Tourism and Hospitality Management)	As per UGC Guideline
2013-14	Community College (Advance Diploma in Financial Services)	As per UGC Guideline
2013-14	Community College (Advance Diploma in Mobile communication)	As per UGC Guideline
2013-14	Career Oriented Courses (Advance Diploma in Banking and Insurance)	As per UGC Guideline
2013-14	Career Oriented Courses (Advance Diploma in Tourism Management)	As per UGC Guideline

2.4.5 How many Emeritus / Adjunct Faculty / Visiting Professors are on the rolls of the university?

No Emeritus / Adjunct Faculty / Visiting Professors are on the rolls of the university.

2.4.6 What policies/systems are in place to academically recharge and rejuvenate teachers (e.g. providing research grants, study leave, nomination to national/international conferences/seminars, in-service training, organizing national/international conferences etc.)?

- The university provides research grants to teachers of different departments.
- The university has a separate budget for teachers for participation in national / international conferences three times in an academic year.

- Teachers are granted duty leave for participating / presenting research papers in National / International seminars / conferences/workshops.
- Teachers are granted study leave to join academic trainings of longer duration in national and international laboratories /universities.
- Teachers are encouraged to participate in orientation and refresher course of UGC Academic Staff Colleges.
- The university also encourages departments to organize international and national seminars/ symposia and conferences

2.4.7 How many faculty received awards / recognitions for excellence in teaching at the state, national and international level during the last four years?

Yes, teachers have received awards or recognition for excellence in teaching at the state, national or international level.

- Dr. A G Modi, got prestigious Raman Fellowship (Post Doctoral) under Indo-US bilateral cooperation.
- Ar. Rajesh Mehta from Institute of Architecture has received prestigious Asia Pacific International Award

2.4.8 How many faculty underwent staff development programmes during the last four years (add any other programme if necessary)?

Academic Staff Development Programmes	Number of faculty
Refresher courses	6
Short term courses	22
Orientation programmes	23
Staff training conducted by the university	19
Staff training conducted by other institutions	34
Summer / Winter schools, workshops, etc.	-
HRD programmes	-

2.4.9 What percentage of the faculty have

- * been invited as resource persons in Workshops / Seminars / Conferences organized by external professional agencies?
25%
- * participated in external Workshops / Seminars / Conferences recognized by national/ international professional bodies?

79%

- * presented papers in Workshops / Seminars / Conferences conducted or recognized by professional agencies?

10%

- * teaching experience in other universities / national institutions and other institutions?

7%

- * industrial engagement?

5%

- * international experience in teaching?

1%

2.4.10 How often does the university organize academic development programmes (e.g.: curriculum development, teaching-learning methods, examination reforms, content / knowledge management, etc.) for its faculty aimed at enriching the teaching-learning process?

The university organized many research initiative programmes. In three phases in which the teachers from the campus as well as from the affiliated colleges were taught to prepare proposals for research project.

University conducted various workshops to familiarize the teachers with the CBCS system.

University organized several workshops and interactions with Knowledge Consortium of Gujarat for content / knowledge management and teaching-learning methods/SPSS workshops for improving research quality/Computer training of non-teaching staff in association with Microsoft.

2.4.11 Does the university have a mechanism to encourage

- * **Mobility of faculty between universities for teaching?**

Yes

- * **Faculty exchange programmes with national and international bodies?**

Yes

If yes, how have these schemes helped in enriching the quality of the faculty?

- ✓ University teachers visit international universities/ institutions and foreign university teachers also visit our university under Full bright and other schemes.
- ✓ Faculties have developed international linkages and MoUs for research and student exchanges

2.5 Evaluation Process and Reforms

2.5.1 How does the university ensure that all the stakeholders are aware of the evaluation processes that are in place?

Seminars are organized for teaching and non-teaching staff to make them aware about CBCS system and other online reforms which the university has introduced in recent times, Students are made aware of these reforms by their teachers.

2.5.2 What are the important examination reforms initiated by the university and to what extent have they been implemented in the university departments and affiliated colleges? Cite a few examples which have positively impacted the examination management system

Answer books from the examination centers are collected in the Central Assessment centers and are mixed and grouped by making bundles of 30 answer books each. The instructions regarding assessment of answer books are given to the examiners and moderators.

The university also follows the below mentioned measures in order to ensure the confidentiality of the evaluation system:

- Bar-coding of answer sheets which ensures confidentiality of the process
- Online generation of exam hall ticket at university departments and colleges
- Full computerization of all result related work
- Availability of all exam related circulars and results on university website.

2.5.3 What is the average time taken by the University for Declaration of examination results? In case of delay, what measures have been taken to address them? Indicate the mode / media adopted by the University for the Publication of examination results (e.g. website, SMS, email, etc.).

The university at declaring examination results within 30 days or latest by 45 days from the date of last paper of any examination. However, owing to shortage of hands and inadequate number of approved teaching faculty for certain courses, the University faces hardships in completing this task within stipulated time. Due to constraints like non availability of examiners and inadequate staff the results of certain courses are delayed. However the university ensures to declare results within 60 days.

The examination results are declared on university website and mark sheets are distributed within 3 to 7 working days.

2.5.4 How does the university ensure transparency in the evaluation process? What are the rigorous features introduced by the university to ensure confidentiality?

Bar-coding of answer sheets have been introduced in certain courses, Centralized assessment process is in place to maintain the confidentiality of the whole process, central assessment with center under CCTV surveillance. Online results and mark sheets are made available to student before they get result from their respective departments/ colleges.

2.5.5 Does the university have an integrated examination platform for the following processes?

- * Pre-examination processes – Time table generation, OMR, student list generation, invigilators, squads, attendance sheet, online payment gateway, etc.

Yes. With the exception of online payment option.

- * Examination process – Examination material management, logistics, etc.

Yes

- * Post-examination process – Attendance capture, OMR-based exam result, auto processing, generic result processing, certification, etc.

Yes

2.5.6 Has the university introduced any reforms in its Ph.D. evaluation process?

Yes, the University is following the UGC rules for admission to Ph.D. programmes and has introduced Pre-Eligibility Test (PET) as written examination, followed by interview as per UGC regulations 2009. Course work is also conducted as per UGC regulations 2009.

The panel of referees for the evaluation of Ph. D. thesis consists of two referees one from within the state and the other from outside the state. Open viva voce is conducted in which the candidate defends the research work done by him/her.

2.5.7 Has the university created any provision for including the name of the college in the degree certificate?

Yes, the university assigns unique code to each college. The name of the college is printed in the mark sheets and also in the degree certificate.

2.5.8 What is the mechanism for redressal of grievances with reference to examinations?

The students' grievance redressal process becomes operational

from onset of examination process even after the results are out. While time table of the examinations are hosted or published, if for any reason it clashes with some other National level examination or falls on holidays, the administration sympathetically looks into the requests and changes the dates. During examination if students complain that the questions are out of syllabus, the Examination Committee immediately addresses the issue. In case of any serious discrepancy noted at any stage of examination, a decision is taken on the conduct of re-examination of the paper concerned. A student gets to see his/her answer scripts if so desired. rechecking and reassessment of answer sheet is also done if a student desires the same.

2.5.9 What efforts have been made by the university to streamline the operations at the Office of the Controller of Examinations? Mention any significant efforts which have improved the process and functioning of the examination division/section.

Examination Section has adequate infrastructure for smooth functioning. The Controller of Examinations and staff have spacious rooms and state-of-the-art facilities like high configuration computers, power inverters, FAX , photo-copiers, hi-speed (fiber optic cable based) internet, so that important functions remain operational throughout the year. A noteworthy feature which has been added recently is the construction of a building called Result Centre which also serves as Central Assessment Centre.

The affiliated colleges submit the results of the continuous comprehensive evaluation (internal tests, seminar, project work and practical marks) online/through electronic means.

2.6. Student Performance and Learning Outcomes

2.6.1 Has the university articulated its graduate attributes? If so, how does it facilitate and monitor its implementation and outcome?

While designing a course, care has been taken to explicitly state the learning objectives for all the papers covered in a particular course/programme. Duly considered BOS supported with academic experts and participation of industry/trade/commerce/NGO experts help in identifying the attributes and learning objectives.

2.6.2 Does the university have clearly stated learning outcomes for its academic programmes/departments? If yes, give details on how the students and staff are made aware of these?

The basic objective of academic programs is employability,

entrepreneurship development, development of self confidence and enhancing intellectual faculties and researchers. Taking into consideration these objectives, the university has framed its curriculum of various programs. The teachers and students are also aware of their goals and try their level best to achieve their goals through their regular teaching, learning and evaluation process.

2.6.3 How are the university's teaching, learning and assessment strategies structured to facilitate the achievement of the intended learning outcomes?

A compulsory component of internal assessment of 30% weightage based on class tests has been introduced for better and continuous participation of students under the semester system.

Presentation of seminar papers is made a component of PG Programmes which enhances the knowledge level of the students and gives them necessary confidence and the ability to logically argue.

Study tours/industrial visits are organized regularly to give the students first hand experience of the newly developed technologies in their respective fields and to enhance their career opportunities.

A lot of laboratory experiments are conducted in order to give basic knowledge of various science subjects.

In addition to the traditional teaching, most faculty members use innovative teaching methods such as ICT enabled teaching aids.

The faculty members of the University and affiliated colleges have been encouraged to participate and/or organize seminars, conferences, workshops, refresher and orientation courses as well as to present research papers so as to keep pace with the recent developments in their subject area.

The faculty members and students have access to books, journals and electronic resources.

The coaching classes for NET/SET are conducted regularly through the Coaching Scheme of the UGC for SC/ST/OBC (Non-Creamy Layer) and Minorities to impart NET/SET guidance to the students.

The Remedial Coaching classes for SC/ST/OBC (non-creamy layer) and Minorities is being conducted regularly.

Smt. Vidyaben Deepchandbhai Gardi Chair/SPIPA center in the University is regularly conducting training programmes to impart training and guidance to all students aspiring for career in Civil Services and other competitive exams.

2.6.4 How does the university collect and analyse data on student learning outcomes and use it to overcome the barriers to learning?

The continuous evaluation (Internal Assessment) and the results of end semester examinations are the indicators to review the

student's outcome at the end of learning process.

The University collects the data and analyses student learning outcomes through: Internal Assessments – Class Tests, Assignments and Class Room Presentations.

The performance of the students at the end semester examinations are analyzed and discussed and the necessary steps like – organization of extra classes, remedial coaching and more assignments are given to the students to overcome the obstacles in learning.

2.6.5 What are the new technologies deployed by the university in enhancing student learning and evaluation and how does it seek to meet fresh/ future challenges?

The following technologies have been deployed during last few years for enhancing students learning and evaluation:

Establishment of Campus-wide Area Network with Internet connectivity of 1 Gbps under NKN (National Knowledge Network) Project of MHRD for e-resource access is under process

Free access to e-journals, databases and other online resources through INFLIBNET UGC-Infonet Digital Library Consortium.

Smart-classrooms in each Department equipped with LCD projector, other accessories.

Computer Laboratories with Internet connectivity to the students in Few of our departments.

Desk-top computers/lap tops, printer, scanner with Internet connectivity have been provided to each faculty.

Establishment of language laboratory in the Department of English is an important step in providing ICT-enabled platform to the students to improve their communication skills, group discussion practices, and phonetics.

The university has procured special softwares such as – MATLAB, PROWESS, Capitaline, and many others.

Any other information regarding Teaching, Learning and Evaluation which the university would like to include.

CRITERION III: RESEARCH, CONSULTANCY AND EXTENSION

3.1 Promotion of Research

3.1.1 Does the university have a Research Committee to monitor and address issues related to research? If yes, what is its composition? Mention a few recommendations which have been implemented and their impact.

The University has a statutory body known as BUTR which monitors and addresses issues related to research and Ph. D. program.

Ph. D. Screening Committee consists of

- Dean of the concerned faculty (Convener)
- Chairman of Board of Studies of the subject concerned
- Head of the Department concerned,
- Ph. D. guides of the subject concerned (not more than three, nominated by the Vice Chancellor),
- Not more than two Subject Expert from other University, nominated by the Vice Chancellor.
- The University strictly follows UGC specified minimum standards and procedures for the award of Ph. D. degree, Regulation 2009.

Candidates having cleared the written entrance test (First and second sections) will be required to take an oral viva-voce of 100 marks conducted by the concerned university department. It will be compulsory for all candidates (including the candidates who have cleared Net/Set etc. or passed M.Phil. with entrance tests after 2009) to take oral viva-voce and clear the same ,separately, with a minimum of 40% marks.

For allotment of students and identifying proper guides (depending upon the expertise of the guides and areas of interest of students) there is four member committee chaired by the heads of the university departments of the concerned subjects. Decision of the committee shall be final in this matter.

A soft copy of the thesis (PDF format) must be forwarded to INFLIBNET and the same PDF format in CD must be forwarded to the UGC New Delhi. If the language used in the thesis is other than English, a summary in English must be submitted along with the thesis and the same must be forwarded to the INFLIBNET and UGC.

On recommendation of the Board of University Teaching and Research (BUTR), the Executive Council shall appoint a panel of three Examiners, one of whom shall be an internal referee; the University teacher guiding the candidate's work, and the other two must be external ones, i.e. from outside the Gujarat state. For this purpose the Board of University Teaching and Research shall recommend a panel

of at least 7 (seven) names of examiners in the subject besides the guide (s).

University has installed research software like SPSS, Matlab, PROWESS, capitaline CL 2000, ACE Analyzer (Accord Fintech) etc. and has subscribed online research sources like Proquest, DELNET, etc. Various journals, books, magazines, etc. are also procured routinely to promote the research activities of University.

International and national level conferences have been organized at regular intervals to share the research knowledge with outside world.

Research Methodology Workshops, Case Writing Workshops, Seminars and FDPs for faculty members and Research Paper Presentation are organized in the University at regular intervals.

Faculty members of the university participate regularly in various national and international seminars and conferences as resource persons/delegates.

3.1.1 What is the policy of the university to promote research in its affiliated / constituent colleges?

University has conducted one initiative for promoting research under which university has organized Research Marathon in three phases like Research Initiatives Phase-I, II, III Workshop under which all participant from university ,affiliated and constituent colleges have prepared research proposals in various interdisciplinary areas and submitted to different funding agencies like UGC, ICSSR, DSTs, CSIR, GUJCOST, GSBTM and many more.

Details of research marathon are mentioned below:

1. 1st phase of research marathon was conducted on 21st Oct 2010, in which 46 participants participated.
2. 2nd phase of research marathon was conducted on 10-12 Jan 2011, in which 66 participants participated and 62 proposals were prepared.
3. 3rd phase of research marathon was conducted on 5th July 2011, in which 35 participants participated.
4. Again in association with AIU one workshop “*March towards the Research*” on research was conducted from 21-24 Nov 2011 were 127 participants from various affiliated colleges who attended it.

3.1.2 What are the proactive mechanisms adopted by the university to facilitate the smooth implementation of research schemes/ projects?

University facilitates faculty member to undertake research in emerging disciplines by providing research funds (seed money). Rs. 15 lac disbursed amongst the faculty members in World Class Uni. Grant (SG)

Adequate attention is paid to proposal preparation and their submission to relevant funding agency. All proposals are channelized and forwarded through registrar office.

As soon as the proposals are accepted and university is informed about sectioning the grant amount, the CAO takes care to see that the research grant is released to the PI as quickly as possible.

The audit section informs PI & Co-PI about maintaining Heads of allotted grants and timely submission of progress report. On final completion of the project, the report is submitted to funding agency with utilization certificate.

3.1.3 How is interdisciplinary research promoted?

University departments are associated with various prestigious organizations for our research projects like

1. International Bear Research and Management Association, USA,
2. The Ruffords Foundation, UK,
3. Ministry of Consumer Affairs, New Delhi,
4. Science and Engineering Research Board, DST, New Delhi,
5. Sardar Sarovar Narmada Nigam Ltd,
6. Gujarat Forest Research Institute, Gandhinagar,
7. Gujarat State Biotechnology Mission, Gandhinagar,
8. Gujarat Council On Science & Technology (GUJCOST), Gandhinagar,
9. Indian Council of Social Science Research (ICSSR), New Delhi
10. UGC, New Delhi

The University encourages its faculty members to conduct more interdisciplinary research work, and various funding agencies have also provided grants to our faculties.

The university has received total Rs. 27628347/- grant from above mentioned funding agencies.

Details of research projects is as under

Sr. No	Title	Name of PI	Funding Agency	Amount
1	Evaluation and Assessment of Man-Animal Conflicts in North Gujarat Region	Dr. Nishith Dharaiya	Gujarat Forest Research Institute, Gandhinagar	684000
2	Study on Occurrence, Distribution and Status of Small Mammals in North Gujarat	Dr. Nishith Dharaiya	Gujarat Forest Research Institute, Gandhinagar	660000

3	Isolation of PHB producing microorganisms from edible oil contaminated soil	Mr. Darshan Marjadi	UGC	180000
4	Study of Novel Antibiotic from Saline Desert Microbial Diversity for Anti MRSA Activity	Dr. Rajesh Patel	UGC (Ref : F/37-550/2009, Dated Dec 23, 2009)	200000
5	Cumin Blight Managment Strategy Formulation	Dr. Rajesh Patel	Gujarat council on Science and Technology (Ref : Gujcost /SSP/201469/2009-10, Dated Jan 8, 2010)	25000
6	Saline desert Metagenomics exploration for Commercially valueable enzyme	Dr. Rajesh Patel	Gujarat State Biotechnology Mission, Gandhinagar	1213480
7	Microbial degradation hydrocarbon and Bio Surfactant Production from oil well isolates of North Gujarat Region	Dr. Rajesh Patel	Gujarat State Biotechnology Mission, Gandhinagar (ref Gujcost 2010-11/409, Dated March 14, 2011)	18000
8	Metaproteomic Analysis of a Different Protein Response to Soil Salinity.	Dr. Ashish Patel	University Grant Commission (UGC)	1473830
9	UGC-BSR Start up Grant	Dr Himanshu Bariya	UGC, New Delhi	600000
10	Identification of Enteric Pathogens from Wild Bird Population	Dr. Sanjay Dave	GUJARAT COUNCIL ON SCIENCE & TECHNOLOGY (GUJCOST), GANDHINAGAR	18400

11	Identification and Characterization of Enteric Bacteria in Wild Bird Species	Dr. Sanjay Dave	GUJARAT STATE BIOTECHNOLOGY MISSION (GSBTM), GANDHINAGAR	1057300
12	Role of Mass Communication in Tribal Development – A Case Study of Tribal Sub Plan Area of Gujarat	Dr. Manoj Kumar Lodha	University Grants Commission, New Delhi	125000
13	Violation of Women Rights in Patan District	Mr. Mitul Deliya	Indian Council of Social Science Research (ICSSR), New Delhi	508475
14	Women's Empowerment : A study of Sakhi Mandal Yojana (SMY) & Its Impact on Women of Rural Area of Patan District	Dr. Nishith Bhatt	UGC, New Delhi	130000
15	Study on synergistic effect of phytochemicals with antibiotics against multidrug resistance bacteria	Dr. Piyush Vyas	UGC (Ref UGC F/41/361/2012, Date july 13, 2012	
16	Evaluating habitats and Human-bear conflicts the in North Gujarat	Dr. Nishith Dharaiya.	The Ruffords Foundation, UK	390000
17	Restoration of endangered plants around Narmada Canal in North Gujarat through ex situ conservation: Saraswati Van	Dr. Nishith Dharaiya	Sardar Sarovar Narmada Nigam Ltd	1350000
18	“A Study on effectiveness of Environmental	Dr.Smita B. Vyas	UGC	80000

	Laws in North Gujarat, Special Reference to Human Rights”			
19	Effect of Brassinosteroids on Protein Profiling of some Groundnut Cultivars of Gujarat under Salinity Stress	Dr. Illa C patel	UGC	908800
20	Influence of Arid and Semi-arid Soil Microbial Composition on Growth, Water Status and Nutrient Uptake Mechanism in Certain Bioindicator Plant of North Gujarat Region Under Saline Condition	Dr. Ashish Patel	Gujarat State Biotechnology Mission (GSBTM)	1900600
21	Characterization of fungal elicitors and their role in expression of resistance gene in <i>Arachis hypogaea</i> L.	Dr. Himanshu Bariya	Science and Engineering Research Board, DST, New Delhi	1085000
22	Patan Jain Gyan Bhandar : Importance, Limitations and Solutions	Prof. Devsinh Bhalabhai Rathva	UGC, New Delhi	130000
23	Contribution of Mass Media in Socio-Economic Development (A Study of Tribal Area Sub Plan of Gujarat)	Dr. Manoj Lodha	Hemchandracharya North Gujarat University, Patan	120000

24	A Comparative study of impact of TV commercials on Rural-Urban Girls of Gujarat	Dr. Manoj Lodha	University Grants Commission, New Delhi	100000
25	Monitoring and Assessment of coastal wetlands of Gulf of Kachchh using avifauna as a key indicator	Dr Nishith Dharaiya	University Grants Commission	983800
26	Estimating carbon sequestration from native trees: an Approach to combat the climate change	Dr Nishith Dharaiya	Gujarat Council on Science and Technology	138000
27	Detecting and monitoring sloth bears at the northern edge of their range	Dr Nishith Dharaiya	International Bear Research and Management Association, USA	250000
28	Ruffords Booster Research Grants	Dr Nishith Dharaiya	Ruffords Small Grants Foundation, UK	700000
29	Data mining from Sanskrit literature and its relevance with current scientific information for metal technology	Prof. Dilip C. Patel	UGC, New Delhi	85000
30	Exploring and Creating the database of extinct words from local Language of North Gujarat Region.	Dr. Sanat B. Joshi	UGC, New Delhi	100000
31	Cause and Condition of Child Labor in Patan District	Mr. Mitul M. Deliya	Hemchandracharya North Gujarat University, Patan	105000

32	INSPIRE Programme	Dr. Ashish Patel	Department of Science and Technology	3200000
33	Monitoring and Evaluating A Nutritional Health Status and Morbidity of School Going Children and Initiating Nutrition Health Education Programme.	Dr. Ashish Patel	Department of Science and Technology (DST)	1224000
34	મહેસાણા -પાટણ જિલ્લામાં આવેલી બીજી થી સોળમી સદી શુધીની પ્રાચીન વાવાનો કાળ નિર્ણય અને તેની સાથે જોડાયેલ દંતકથાઓ અને તેની ઐતિહાસિક મૂલ્યોને ઉદઘાટીત કરવું .	Prof.Dilip C.Patel	Hemchandrachary North Gujarat University ,Patan	110000
35	Diversity and Biotechnological application of Endophytic Microflora of Saline Desert	Dr. Rajesh Patel	Hem. North Gujarat University	110000
36	Development of effective propagation methods for some conservation	Dr. Illa C. Patel	Hemchandracharya North Gujarat University, Patan (Research Fund)	120000

	concern medicinal plants of north Gujarat			
37	A Comparative Study Of Primary Schools Having Higher & Lower Grade Assigned During Gunotsav	Tandel Sudhirkumar Haribhai	SSA, Gandhinagar	670000
38	Impact of Direct to Home Services on Television viewing habits of rural consumers: Implications for DTH and other potential industries -A comprehensive Study of Rural area of North Gujarat	Mrs. Kavita Trivedi	UGC	121000
39	A study on Consumer Satisfaction from Healthcare organizations : Promoting Healthcare Consumerism at Gujarat	Dr. Ashwin Modi	Ministry of Consumer Affairs, New Delhi	379000
40	Evaluation of some potent anti-HIV compounds obtain from medicinally important plants / heros available around North Gujarat region of India	Dr. K. A. Parmar	UGC, World Class University Grants, HNGU, Patan	150000
41	Isolation, Identification and activity of pesticide	Dr. Shreyas A. Bhatt	UGC, World Class University Grants, HNGU, Patan	120000

	degrading microorganisms from semi-arid soils of North Gujarat			
42	Synthesis characterization Biochemical and catalytic studies on novel complexes of Amino salicylic acid derivatives	Dr. J G. Gurjar	UGC : F:47/Z068/11(WRO)	140000
43	Preparation of Database of Migrants from Gujarat	Dr. Adesh Pal	UGC	*
44	Equilibrium and solid state studies on some hetero chelates	Dr. A. S. Prajapati	UGC	*
45	Vatan Seva : NRG's Contribution of Gujarat	Dr. Adesh Pal	UGC, New Delhi under Area Study Center	*
46	Centre for Indian Diaspora and Cultural Studies Phase 1	Dr. Adesh Pal	UGC, New Delhi under Area Study Center	4,00,000
47	Sonochemical and Photochemical Degradation of Dyes	Prof. Sangita Sharma	GUJCOST	511000
48	Evaluation and Pharmacological Study of few herbs and plants used in Indian system in medicine	Dr. K. A. Parmar	UGC F No: 41-1318/2012 (SR)[2011-12]	155000
49	Study of soil enzymes involved in nitrogen transformation in	Dr. Shreyas A. Bhatt	UGC	197500

	semi-arid soils.			
50	Corrosion inhibition of Tin coated Steel in Acidic medium	Dr. Sangita S. Sharma	UGC	190000
51	Economical position of Retires (Senior Citizen) with special Emphasis on saving, Consumption and Investment Decisions : A study report for North Gujarat region	Ms. Riddhi Gopalkumar Agrawal	UGC	125000
52	DEVELOPING AND TESTING OF SOIL/ INVERTEBRATE INTERACTION	Dr. Sanjay Dave	UGC, NEW DELHI	256000
53	Causes of low utilization of Primary level of Healthcare services in North Gujarat	Dr. Bhupinder Chaudhary	HNGU, Patan	40000
54	Development and evaluation of a novel topical treatment for acne with dual agent loaded nanoliposomes.	Dr. Dhara B. Patel	University Grants Commission	600000
55	Extraction, screening and designing nano novel particulate herbal formulation of Wattakaka Volubilis for anti diabetic and	Dr. Shirish R Patel	University Grants Commission	600000

	hepatoprotective activity			
56	Impact of Sakhi Mandal Yojana on Women Empowerment	Mr. Mitul M. Deliya	UGC, New Delhi	130000
57	Soil / Invertebrates Interaction	Dr. Sanjay Dave	UGC, New Delhi	256000
58	Protein Expression Profile of Haloalkalophilic Bacteria	Dr. Rajesh Patel	GSBTM, Gandhinagar	75000
59	Multi institutional HRD project BitVirtual (Virtual Institute of Bioinformatics) for M. Phil in Bioinformatics	Dr. Rajesh Patel	GSBTM	100000 per year
60	Empowering investors by demystifying performance measurement communications: A study on investors of North Gujarat	Dr. Ashwin Modi	HNGU, Patan	90000
61	Elderly in the Rural areas of north Gujarat: Role, status, Life conditions, problems, solutions	Dr. Gargiben N. Raval	UGC	143000
62	Phytochemical survey and chemical screening of some medicinal plants and herbs: An approach to the	Dr. K. A. Parmar	UGC	87000

	pharmacological activity			
63	Acoustic and Transport Properties of Binary solution of beta pinene with some aromatic hydrocarbon	Dr. Sangita Sharma	GUJCOST	17062
64	Evaluation of social culture and economic transformation in costal communitis of Gujarat	Prof Hemixa Rao	UGC	692100
65	INIPIRE Programme	Dr. Ashish Patel	DST	1600000
66	Centre for Indian Diaspora and Cultural Studies - Phase 2	Prof. Adesh pal	UGC	1000000
67	Economic and social issues confronting the marginalized social groups of Gujarat state	Prof. B A Prajapati	ICSSR, New Delhi.	12,48,000
68	A Comparative study of primary schools having higher & lower grade assigned during Gunotsav	Dr.S H Tandel	SSA Gandhinagar	6,70,540
69	A Study of Administrative & Cultural Adaptation required for Access, Retention and Learning of Tribal Children	Dr.S H Tandel	SSA Gandhinagar	7,57,777
70	UGC-BSR Start Up grant for	Dr. Himanshu	University Grant Commission (UGC),	600000

	newly recruited faculty at Assistant professor level in science department funded by University Grant Commission (UGC), New Delhi	Baraiya	New Delhi	
71	Characterization of fungal elicitors and their role in expression of resistance genes in <i>Arachis hypogaea</i> L. funded by Science and Engineering Research Board, DST, New Delhi	Dr. Himanshu Baraiya	DST, New Delhi	1085000
72	Fungal DNA Barcoding sponsored by Gujarat State Biotechnology Mission (GSBTM), Gandhinagar	Dr. Himanshu Baraiya	Gujarat State Biotechnology Mission (GSBTM), Gandhinagar	1950000

3.1.5 Give details of workshops/ training programmes/ sensitization programmes conducted by the university to promote a research culture on campus.

The University Departments conduct conferences, seminars, workshops or training programmes regularly for promoting a research culture amongst the academics and students, few examples of which are mentioned below:

Sr. No	Name of Training	Name of Organizer	Time Duration(In week)	Year
1	Research Methodology in Social Science	H.N.G. University Patan sponsored by Indian Council of Social Science Research, New Delhi	1.5	2013-14
2	SAKSHAM	H.N.G. University Patan in association with Microsoft	1	2013-14
	Challenges, Opportunities and Innovations in Pharmaceutical Sciences, 13th Feb 2014	Dept. of Pharmaceutical Sciences, HNGU, Patan		2013-14
3	Saksham-It Champion Training Programme	H.N.G. University Patan	1	2013-14
4	Akhil Bhartiya Hemchandracharya Samaroh	H.N.G. University Patan	1	2011-12
5	All India Young Social Scientists Workshop 2011 on "Technology and Society: Issues and Challenges 2011	H.N.G. University Patan	0.4	2011-12
6	Awareness of ISO 9001 : 2008 - Requirements : Quality Management System	H.N.G. University Patan	0.2	2011-12
8	Faculty Development Programme	H.N.G. University Patan	1	2011-12

9	Management Development Programme on Quality Aspects in Healthcare Administration	Department of Hospital Management, HNGU	0.5	2011-12
10	National Workshop on Research Methodology- A March Towards Creating Research Culture	H.N.G. University Patan	0.6	2011-12
11	Training Course on Awareness of ISO 9001 :2008 - Requirements: Quality Management Systems	H.N.G. University Patan	0.2	2011-12
12	All india young scientists "Technology and Society :Issues And Challenges"	H.N.G. University Patan		2010-11
13	Capacity Building	H.N.G. University Patan	0	2010-11
14	Capacity Building Workshop	KCG & HNGU, Patan	1	2010-11
15	Capacity building, 15 October, 2010	H.N.G. University Patan	-	2010-11
16	National Workshop on Research Methodology: A March Towards Creating Research Culture	Jointly organized by AIU Delhi, KCG Gandhinagar, HNGU Patan and NAAC Bangalore	0.6	2010-11
17	Quality Aspects in Healthcare Administration, 23rd - 25th March,	Department of Hospital Management, HNGU, Patan	-	2010-11

	2011.			
18	RESEARCH INITIATIVES	Life Science Department, Hem. North Gujarat University, Patan	-	2010-11
19	Workshop on “Capacity Building”	H.N.G. University Patan	1	2010-11
20	workshop on “Management of higher education in Gujarat state”	H.N.G. University Patan	1	2010-11
21	Workshop on “RESEARCH INITIATIVES”	Life Science Department, Hem. North Gujarat University,	1	2010-11
22	Workshop on “Right to Information Act, 2005 at a glance”	Department of Law, Hem. North Gujarat University,	1	2010-11
23	“Management development programme on quality aspects in healthcare administration”	department of hospital management	1	2010-11
24	Research initiative for HNGU Teachers Phase-I	Department of life sciences, Hem. North Gujarat University, patan. 21 October, 2010	-	2009-10
25	A workshop for reconstruction of CBSC Curriculum and annual Sangoshhthi”	H.N.G. University Patan	-	2008-09
26	Effective Teaching Workshop	Dept. of Computer Science, HNGU,	0.2	2008-09

		PATAN		
27	Research Marathon"	Department of Sanskrit and Bharatiya Vidya and Hemchandracharya North Gujarat University	-	2008-09
28	Research Methodology: A March towards creating research culture,	jointly organized by AIU Delhi, KCG Gandhinagar and NAAC Bangalore Hemchandraua North Gujarat University,patan	-	2008-09
29	Seminar on Super Computing, 2005	Dept. of Computer Science, HNGU, PATAN	0.2	2008-09
30	Workshop of "project Management" based on IUCEE	Dept. of Computer Science,H N G University	1	2008-09
31	International Conference on Relative Economics	MBA	0.5	2011-12
32	National Conference on Financial Aspects	MBA	0.2	2010-11
33	WRSCC-2007	Dept. Of Computer Science, HNGU, PATAN	0.5	2008-09

How does the university facilitate researchers of eminence to visit the campus as adjunct professors? What is the impact of such efforts on the research activities of the university?

The university has provision for appointment of adjunct professors.

3.1.6 What percentage of the total budget is earmarked for research? Give details of heads of expenditure, financial allocation and actual utilization.

University facilitates faculty members to undertake research in emerging disciplines by providing research funds (seed money). Rs. 15 lac has already been disbursed amongst the faculty members in World Class Uni. Grant (SG)

3.1.7 In its budget, does the university earmark fund for promoting research in its affiliated colleges? If yes, provide details.

No.

3.1.8 Does the university encourage research by awarding Post Doctoral Fellowships/Research Associate ships? If yes, provide details like number of students registered, funding by the university and other sources.

Yes. Post Doctoral Fellowships/Research Associate ships are provided by the UGC, DST, DBT, CSIR and others.

Under the Indian council for social sciences research, Ministry of human resource development, JNU Campus, New Delhi university has got project on “ Economic and social issues confronting the marginalized social groups of Gujarat state” amounting Rs.1248000/-.

Under this project two Research Assistants have been appointed whose names are given bellow:

1. Mr. Bharat M Prajapati
2. Mr. Nisarg A Khamar

Under project from Ministry of Consumer affairs, New Delhi - A study on Consumer Satisfaction from Healthcare organizations: Promoting Healthcare Consumerism at Gujarat amounting Rs .379000/-

Under this project one Research Assistant has been appointed whose name is given bellow:

1. Miss. Aarti V Dave

What percentage of faculty has utilized the sabbatical leave for pursuit of higher research in premier institutions within the country and abroad? How does the university monitor the output of these scholars?

None of the university faculty has availed of sabbatical leave in the last five years.

3.1.9 Provide details of national and international conferences organized by the university highlighting the names of eminent scientists/scholars who participated in these events.

The details about national and international conferences organized by the university are mentioned below:

- The UGC Area Study Centre for Indian Diaspora and Cultural Studies organized an international conference on “Reconnecting Gujarati Diaspora with its Homeland: Contribution to its Development with focus on Building a Knowledge society” from 17th to 19 January, 2009 in which the following eminent scholars participated actively:
 - Dr. Kamlesh Lulla, Chief Scientist in Human Exploration Science, NASA, Johnson Space Centre, Houston, Texas (USA)
 - Prof. Mohan K. Gautam, Deptt. Of South and Central Asian Studies, Leiden University, Netherlands.
 - Edward Simpson, Department of Anthropology and Sociology, SOAS(School of Oriental and African Studies), University of London

- The UGC Area Study Centre for Indian Diaspora and Cultural Studies organized an international conference on “Celebrating 50th Year of Swarnim Gujarat: The Role of Gujarati Diaspora” from 2nd to 4th January, 2011 in which the following eminent scholars participated actively:
 - Shri J.C. Sharma, Secretary (Former), Policy planning, Consular and Diaspora, Ministry of External Affairs, Government of India, New Delhi
 - Dr. Kamlesh Lulla, Chief Scientist in Human Exploration Science, NASA, Johnson Space Centre, Houston, Texas (USA)
 - Mr. Deepak B. Trivedi, Director, Information Services, Council on Foreign Relations, New York, USA
 - Edward Simpson, Department of Anthropology and Sociology, SOAS(School of Oriental and African Studies), University of London
 - Patricia Lee Dorff, Editorial Director, CFR Publishing, Council on Foreign Relations, New York.

- Jacqueline Leckie, Associate Professor, Department of Anthropology, University of Otago, Dunedin, New Zealand.

3.2 Resource Mobilization for Research

3.2.1 What are the financial provisions made in the university budget for supporting students' research projects?

University facilitates students to undertake research in emerging disciplines by providing research funds (seed money). Rs. 10 lac was disbursed amongst the students under the World Class Uni. Grant (SG)

3.2.2 Has the university taken any special efforts to encourage its faculty to file for patents? If so, how many have been registered and accepted?

No

3.2.3 Provide the following details of ongoing research projects of faculty:

A. University Awarded Projects

Sr. No	Title	Name of PI	Funding Agency	Amount
1	Contribution of Mass Media in Socio-Economic Development (A Study of Tribal Area Sub Plan of Gujarat)	Dr. Manoj Lodha	Hemchandracharya North Gujarat University, Patan (Research Fund)	120000
2	Cause and Condition of Child Labor in Patan District	Mr. Mitul M. Deliya	Hemchandracharya North Gujarat University, Patan (Research Fund)	105000
3	મહેસાણા -પાટણ જિલ્લામાં આવેલી બીજી થી સોળમી સદી શુધીની પ્રાચીન વાવાનો કાળ નિર્ણય અને તેની સાથે	Dr.Dilip C.Patel	Hemchandracharya North Gujarat University, Patan (Research Fund)	110000

	જોડાયેલ દંતકથાઓ અને તેની ઐતિહાસિક મૂલ્યોને ઉદઘાટીત કરવું .			
4	Diversity and Biotechnological application of Endophytic Microflora of Saline Desert	Dr. Rajesh Patel	Hemchandracharya North Gujarat University, Patan (Research Fund)	110000
5	Development of effective propagation methods for some conservation concern medicinal plants of north Gujarat	Dr. Illa C. Patel	Hemchandracharya North Gujarat University, Patan (Research Fund)	120000
6	Evaluation of some potent anti-HIV compounds obtain from medicinally important plants / heros available around North Gujarat region of India	Dr. K. A. Parmar	Hemchandracharya North Gujarat University, Patan (Research Fund)	150000
7	Isolation, Identification and activity of pesticide degrading microorganisms from semi-arid soils of North Gujarat	Dr. Shreyas A. Bhatt	Hemchandracharya North Gujarat University, Patan (Research Fund)	120000
8	Causes of low utilization of Primary level of Healthcare services in North Gujarat	Dr. Bhupinder Chaudhary	Hemchandracharya North Gujarat University, Patan (Research Fund)	40000
9	Empowering investors by demystifying performance	Dr. Ashwin Modi	Hemchandracharya North Gujarat University, Patan (Research Fund)	90000

	measurement communications:A study on investors of North Gujarat			
--	--	--	--	--

B. UGC Awarded Projects

Sr. No	Title	Name of PI	Funding Agency	Amount
1	Isolation of PHB producing microorganisms from edible oil contaminated soil	Mr. Darshan Marjadi	UGC, New Delhi	180000
2	Study of Novel Antibiotic from Saline Desert Microbial Diversity for Anti MRSA Activity	Dr. Rajesh Patel	UGC (Ref : F/37-550/2009, Dated Dec 23, 2009)	200000
3	Metaproteomic Analysis of a Different Protein Response to Soil Salinity.	Dr. Ashish Patel	University Grant Commission (UGC)	1473830
4	UGC-BSR Start up Grant	Dr Himanshu Bariya	UGC, New Delhi	600000
5	Role of Mass Communication in Tribal Development – A Case Study of Tribal Sub Plan Area of Gujarat	Dr. Manoj Kumar Lodha	University Grants Commission, New Delhi	125000
6	Women's Empowerment : A study of Sakhi Mandal Yojana (SMY) & Its Impact on Women of Rural Area of Patan District	Mr. Nishith Bhatt	UGC, New Delhi	130000
7	“A Study on effectiveness of Environmental	Dr.Smita B. Vyas	UGC, New Delhi	80000

	Laws in North Gujarat, Special Reference to Human Rights”			
8	Effect of Brassinosteroids on Protein Profiling of some Groundnut Cultivars of Gujarat under Salinity Stress	Dr. Illa C patel	UGC, New Delhi	908800
9	Patan Jain Gyan Bhandar : Importance, Limitations and Solutions	Prof. Devsinh Bhalabhai Rathva	UGC, New Delhi	130000
10	A Comparative study of impact of TV commercials on Rural-Urban Girls of Gujarat	Dr. Manoj Lodha	University Grants Commission, New Delhi	100000
11	Monitoring and Assessment of coastal wetlands of Gulf of Kachchh using avifauna as a key indicator	Dr Nishith Dharaiya	University Grants Commission	983800
12	Data mining from Sanskrit literature and its relevance with current scientific information for metal technology	Dr. Dilip C. Patel	UGC, New Delhi	85000
13	Exploring and Creating the database of extinct words from local Language of North Gujarat Region.	Dr. Sanat B. Joshi	UGC, New Delhi	100000

14	Impact of Direct to Home Services on Television viewing habits of rural consumers: Implications for DTH and other potential industries - A comprehensive Study of Rural area of North Gujarat	Mrs. Kavita Trivedi	UGC, New Delhi	121000
15	Synthesis characterization Biochemical and catalytic studies on novel complexes of Amino salicylic acid derivatives	Dr. J G. Gurjar	UGC : F:47/Z068/11(WRO)	140000
16	Preparation of Database of Migrants from Gujarat	Dr. Adesh Pal	UGC, New Delhi	
17	Equilibrium and solid state studies on some hetero chelates	Dr. A. S. Prajapati	UGC, New Delhi	
18	Vatan Seva : NRG's Contribution of Gujarat	Dr. Adesh Pal	UGC, New Delhi under Area Study Center	
19	Centre for Indian Diaspora and Cultural Studies	Dr. Adesh Pal	UGC, New Delhi under Area Study Center	400000
20	Evaluation and Pharmacological Study of few herbs and plants used in Indian system in medicine	Dr. K. A. Parmar	UGC F No: 41-1318/2012 (SR)[2011-12]	155000
21	Study of soil enzymes involved in nitrogen transformation in semi-arid soils.	Dr. Shreyas A. Bhatt	UGC, New Delhi	197500
22	Corrosion inhibition	Dr. Sangita	UGC, New Delhi	190000

	of Tin coated Steel in Acidic medium	S. Sharma		
23	Economical position of Retires (Senior Citizen) with special Emphasis on saving, Consumption and Investment Decisions : A study report for North Gujarat region	Ms. Riddhi Gopalkumar Agrawal	UGC, New Delhi	125000
24	DEVELOPING AND TESTING OF SOIL/ INVERTEBRATE INTERACTION	Dr. Sanjay Dave	UGC, NEW DELHI	256000
25	Development and evaluation of a novel topical treatment for acne with dual agent loaded nanoliposomes.	Dr. Dhara B. Patel	UGC, New Delhi	
26	Impact of Sakhi Mandal Yojana on Women Empowerment	Mr. Mitul M. Deliya	UGC, New Delhi	130000
27	Soil / Invertebrates Interaction	sanjay dave	UGC, New Delhi	256000
28	Elderly in the Rural areas of north Gujarat: Role, status, Life conditions, problems, solutions	Dr. Gargiben N. Raval	UGC, New Delhi	143000
29	Phytochemical survey and chemical screening of some medicinal plants and herbs:An approach to the pharmacological activity	Dr. K. A. Parmar	UGC, New Delhi	87000

30	Evaluation of social culture and economic transformation in costal communities of gujarat	Prof Hemixa Rao	UGC, New Delhi	692100
31	Centre for Indian Diaspora and Cultural Studies	Prof. Adesh pal	UGC, New Delhi	1000000

C. Other Institutions Awarded projects:

Sr. No	Title	Name of PI	Funding Agency	Amount
1	Evaluation and Assessment of Man-Animal Conflicts in North Gujarat Region	Dr. Nishith Dharaiya	Gujarat Forest Research Institute, Gandhinagar	684000
2	Study on Occurrence, Distribution and Status of Small Mammals in North Gujarat	Dr. Nishith Dharaiya	Gujarat Forest Research Institute, Gandhinagar	660000
3	Cumin Blight Managment Strategy Formulation	Dr. Rajesh Patel	Gujarat council on Science and Technology (Ref : Gujcost /SSP/201469/2009-10, Dated Jan 8, 2010)	25000
4	Saline desert Metagenomics exploration for Commercially valueable enzyme	Dr. Rajesh Patel	Gujarat State Biotechnology Mission, Gandhinagar	1213480
5	Microbial degradation hydrocarbon and Bio Surfactant Production from oil well isolates of North Gujarat Region	Dr. Rajesh Patel	Gujarat State Biotechnology Mission, Gandhinagar (ref Gujcost 2010-11/409, Dated March 14, 2011)	18000

6	Identification of Enteric Pathogens from Wild Bird Population	Dr. Sanjay Dave	GUJARAT COUNCIL ON SCIENCE & TECHNOLOGY (GUJCOST), GANDHINAGAR	18400
7	Identification and Characterization of Enteric Bacteria in Wild Bird Species	Dr. Sanjay Dave	GUJARAT STATE BIOTECHNOLOGY MISSION (GSBTM), GANDHINAGAR	1057300
8	Violation of Women Rights in Patan District	Mr. Mitul Deliya	Indian Council of Social Science Research (ICSSR), New Delhi	508475
9	Evaluating habitats and Human-bear conflicts the in North Gujarat	Dr. Nishith Dharaiya.	The Ruffords Foundation, UK	390000
10	Restoration of endangered plants around Narmada Canal in North Gujarat through ex situ conservation: Saraswati Van	Dr. Nishith Dharaiya	Sardar Sarovar Narmada Nigam Ltd	1350000
11	Influence of Arid and Semi-arid Soil Microbial Composition on Growth, Water Status and Nutrient Uptake Mechanism in Certain Bioindicator Plant of North Gujarat Region Under Saline Condition	Dr. Ashish Patel	Gujarat State Biotechnology Mission (GSBTM)	1900600
12	Characterization of fungal elicitors and their role in expression of resistance gene in <i>Arachis hypogaea</i> L.	Dr. Himanshu Bariya	Science and Engineering Research Board, DST, New Delhi	1085000

13	Estimating carbon sequestration from native trees: an Approach to combat the climate change	Dr Nishith Dharaiya	Gujarat Council on Science and Technology	138000
14	Detecting and monitoring sloth bears at the northern edge of their range	Dr Nishith Dharaiya	International Bear Research and Management Association, USA	250000
15	Ruffords Booster Research Grants	Dr Nishith Dharaiya	Ruffords Small Grants Foundation, UK	700000
16	INSPIRE Programme	Dr. Ashish Patel	Department of Science and Technology	3200000
17	Monitoring and Evaluating A Nutritional Health Status and Morbidity of School Going Children and Initiating Nutrition Health Education Programme.	Dr. Ashish Patel	Department of Science and Technology (DST)	1224000
18	A COMPARATIVE STUDY OF PRIMARY SCHOOLS HAVING HIGHER & LOWER GRADE ASSIGNED DURING GUNOTSAV	Tandel Sudhirkumar Haribhai	SSA, Gandhinagar	670000
19	A study on Consumer Satisfaction from Healthcare organizations : Promoting Healthcare	Dr. Ashwin Modi	Ministry of Consumer Affairs, New Delhi	379000

	Consumerism at Gujarat			
20	Sonochemical and Photochemical Degradation of Dyes	Prof. Sangita Sharma	GUJCOST	511000
21	Protein Expression Profile of Haloalkalophilic Bacteria	Dr. Rajesh Patel	GSBTM, Gandhinagar	75000
22	Acoustic and Transport Properties of Binary solution of beta pinene with some aromatic hydrocarbon	DR. Sangita Sharma	GUJCOST	17062
23	INPIRE Programme	Dr. Ashish Patel	DST	1600000

3.2.4 Does the university have any projects sponsored by the industry / corporate houses? If yes, give details such as the name of the project, funding agency and grants received.

Yes, Department of Life Science (Dr. Nishith Dharaiya) has received grant of Rs. 1350000/- from Sardar Sarovar Narmada Nigam Limited for Restoration of endangered plants around Narmada Canal in North Gujarat through ex situ conservation: Saraswati Van

3.2.5 How many departments of the university have been recognized for their research activities by national / international agencies (UGC-SAP, CAS; Department with Potential for Excellence; DST-FIST; DBT, ICSSR, ICHR, ICPR, etc.) and what is the quantum of assistance received? Mention any two significant outcomes or breakthroughs achieved by this recognition.

University departments are recognized for their research activities by national/international agencies

Department of Life sciences/Department of Biotechnology/
Department of Chemistry are recognized by

- International Bear Research and Management Association, USA,
- The Ruffords Foundation, UK,
- Gujarat Forest Research Institute, Gandhinagar,
- Science and Engineering Research Board, DST, New Delhi,
- Sardar Sarovar Narmada Nigam Ltd,
- Gujarat State Biotechnology Mission, Gandhinagar,
- Gujarat Council on Science & Technology (GUJCOST), Gandhinagar
- UGC, New Delhi

Department of Commerce and Management is recognized by

- Ministry of Consumer Affairs, New Delhi,,
- Indian Council of Social Science Research (ICSSR), New Delhi
- UGC, New Delhi

3.2.6 List details of

a. research projects completed and grants received during the last four years

Title	Agency	Sanction Date	Period	Amount	Major/Minor
Department of Chemistry					
Dr. K.A. Parmar					
Evaluation and pharmacological study of few herbs and plants used in Indian system in medicine.	U.G.C. Minor Research Project		F.No.41-1318/2012 (SR) 01-07-2012	1,55,000/-	Completed
Department of Education					
Dr. Rupesh Patel					
Comparative study of schools having higher grades and lower grades during gunotsav programme	SSA, Gandinagar Govt. of Gujarat	24/3/2013	One year	6,70,000/-	major
Dr. Sudhir H. Tandel					

“A Comparative study of primary schools having higher & lower grade assigned during Gunotsav” & “A Study of Effectiveness of Gunotsav Programme on Classroom Teaching”	SSA, Gandhinagar	24/3/2013	One Year	6,70,000/-	Major
Department of Law					
Dr. H. K. Patel					
“A Legal Study on Government Education Policies in Constitutional Perspectives, with special reference to public private partnership in present scenario.”	UGC, New Delhi	F.No. 23-2606/11(WRO) Dt.24/02/2012	2 Years	81,500	Minor Research Project
Department of Biotechnology					
Dr. Sanjay M. Dave					
Identification of enteric pathogens from wild bird population	GUJCOST, Gandhinagar		1 year	18400/-	Minor
Identification and characterization of enteric bacteria in wild bird species	GSBTM, Gandhinagar		3 years	1057300/-	Major

A. (Funded by National/International agencies).
As mentioned in 3.2.3 C.

B. Inter-institutional collaborative projects and grants received
As mentioned in 3.2.3 B, C

3.3 Research Facilities:

3.3.1 What efforts have been made by the university to improve its infrastructure requirements to facilitate research? What strategies have been evolved to meet the needs of researchers in emerging disciplines?

Various journals, books, magazines, etc. are subscribed to promote the research activities of University. International and national level conferences have been organized at regular intervals to share the research knowledge with outside world.

Research Methodology Workshops, Case Writing Workshops, Seminars and FDPs for faculty members and Research Paper Presentation are organized in the University at regular intervals.

Faculty members of the university have participated in various seminars and conferences both at national and international levels as resource persons/delegates. University allows and encourages its faculty members to use the infrastructure such as laboratory, Library, equipments, etc. for an in-depth research in emerging areas and disciplines. Faculty members can explore the facilities of lab, lib, equipments etc.

Faculty members are also encouraged to participate in national and international conferences organized by other universities and institutions in emerging area & disciplines.

Almost all departments have ongoing research, research linkage or academic collaboration with other reputed institutions as a result of which they are motivated further for extensive work in the same area.

University has its own Research Publication 'ANART'.

University Research Initiative is formed to encourage the Research activity amongst staff and students.

3.3.2 Does the university have an Information Resource Centre to cater to the needs of researchers? If yes, provide details of the facility.

	Existing		Newly added		Total	
	No.	Value	No.	Value	No.	Value
Total No. of books in Library	67637	30203095	2195	2299131	69832	32502226
Total No. of Journals Subscribed	-	-	110	300158	110	300158
e-Journals	<ol style="list-style-type: none"> 1. Bentham Pharmacy 2. UGC Infonet 3. INFLIBNET 					

	4. DELNET					
CD & Video	841		364	16295	1205	
Other (Specify) phd Thesis	1060	-	78	-	1138	-
Information on INFLIBNET utility	1. UGC Infonet Programme 2. SOUL 2.0 Software					

E – Journals for Faculty:

Publisher	URL	No. of Journals
American Chemical Society	http://www.pubs.acs.org	37
American Institute of Physics	http://www.aip.org	18
American Physical Society	http://www.aps.org	10
Annual Reviews	http://arjournals.annualreviews.org	33
Blackwell Publishing	http://www.interscience.wiley.com	497
Cambridge University Press	http://journals.cambridge.org	224
Emerald	http://www.emeraldinsight.com	29
Institute of Physics	http://www.iop.org/ej	46
ISID	http://isid.org.in	Database
JCCC	http://www.jccc-ugcinfonet.in	Portal
Oxford University Press	http://www.oxfordjournals.org	202
Project Muse	http://muse.jhu.edu/journals	407
Royal Society of Chemistry	http://www.rsc.org	29+6 Database
Springer Link	http://www.springerlink.com	1950
Taylor and Francis	http://www.informaworld.com	1076
IEEE	http://ieeexplore.ieee.org	147

University has installed research software like SPSS, Matlab, PROWESS etc. and subscribed online research sources like Capitaline, Proquest, Delnet, etc.

3.3.3 Does the university have a University Science Instrumentation Centre (USIC)? If yes, have the facilities been made available to research scholars? What is the funding allotted to USIC?

Central Instrumentation Facility has been developed with the help of

UGC in Department of Chemistry, it is available to researchers of M.Phil and Ph.D. Central Instrumentation Maintenance Facility (CIMF) is also constituted for proper and timely maintenance of sophisticated instruments.

List of equipments

3.3.4 Does the university provide residential facilities (with computer and internet facilities) for research scholars, post-doctoral fellows, research associates, summer fellows of various academies and visiting scientists (national /international)?

Yes, the University provides hostel accommodation to the research scholars, post-doctoral fellows, and research associates, summer fellows of

Sr. No	Instrument Name	Brand Name	Amount
1	CHNS Analyzer	Elementar	2675805.00
2	TGA/DSC.	Mettler-Toledo	3379699.00
3	Gas Chromatography	Bruker	1097733.00
4	HPLC	Elico	796000.00
5	FT IR Spectrometer	Bruker	978226.00
6	Density and Sound Velocity meter	Anton paar	1700544.00
7	Faraday Magnetic Balance	Polytronic	825000.00
8	UV-Vis Spectrometer (Double beam)	Shimadzu	415000.00
9	Spectrofluorophotometer	Shimadzu	895000.00
10	UV-Vis Spectrometer (Double beam)	Thermo Scientific	385000.00
11	UV-Vis Spectrometer (Single beam)	Elico	130000.00

various academies and visiting scientists of the state. While national/international fellows are served with computer and internet facilities under hostel accommodation.

3.3.5 Does the university have a specialized research centre/workstation on-campus and off-campus to address the special challenges of research programmes?

Yes, the University has specialized research centre/workstation on-campus to address the special challenges of research programmes such as Centre/ Chapter of Quality Council of India, New Delhi, Centre/Chapter of Academy of Hospital Administration, New Delhi. This centre assess the quality of healthcare services provided by the healthcare providers. The university also has other centres like:

The Centre for M.Phil Bio-technology, The Centre for BIT Virtual, The Centre for Research Excellence under CIF Cell., The UGC Area Study

Centre for Indian Diaspora and Cultural Studies

3.3.6 Does the university have centres of national and international recognition/repute? Give a brief description of how these facilities are made use of by researchers from other laboratories.

- ❖ The UGC Area Study Centre for Indian Diaspora and Cultural Studies : International scholars from various universities of Australia, Fiji, U.K., and USA have visited the Centre and delivered lectures to the students of the CIDCS.
- ❖ BIO-NUT Research Centre

3.4 Research Publications and Awards

3.4.1 Does the university publish any research journal(s)? If yes, indicate the composition of the editorial board, editorial policies and state whether it/they is/are listed in any international database.

University has its own Research Publication ‘ANART’ which is a bi-annual journal published regularly in the month of June and December every year. ISSN : 2229-4376

Editorial Board: Dr. M.G. Patel, Dr. J. H. Pancholi, Dr. S. A. Bhatt, Dr. K. S. Parikh, Dr. N. H. Bhatt, Dr. B. D. Patel

3.4.2 Give details of publications by the faculty:

The details are as below

Publications	2014-15	2013-14	2012-13	2011-12	2010-11	Total
International level	1	23	109	98	59	301
National level	-	06	33	30	28	99
State level	-	02	03	01	-	06

Publications of Faculties:

Sr. No	Faculty	Research Papers	Books/ Chapter	Research Project	Seminar/ Conference	Training/ FDP	Invited Lectures	Research Students
1	Dr. Manoj lodha	11	4	3	8	0	6	0
2	Darshna Dalvadi	0	0	0	2	0	0	0
3	Agrawal Riddhiben G	3	0	1	3	1	0	0
4	Ar. Bhavesh M. Patel	0	0	0	0	0	0	0
5	Ar. Kaushik Panchal	0	0	0	0	0	0	0
6	Ar. Mayank	0	0	0	0	0	0	0

	K. Patel							
7	Barot Payal Pravinkumar	0	0	0	1	8	4	0
8	Bhaves M Patel	1	0	0	1	10	0	0
9	Chokhawala kiritkumar I	0	0	0	2	0	0	0
10	Dharaben B. Patel	13	2	1	7	2	0	2
11	Dr. A R Patel	15	1	0	1	1	0	0
12	Dr. Aadesh Pal	0	1	3	0	0	0	33
13	Dr. Ashish Patel	8	1	4	1	0	1	0
14	Dr. Ashwin Modi	17	0	2	0	0	0	0
15	Dr. Atul V Kadia	0	2	0	3	2	3	0
16	Dr. B A Prajapati	13	6	0	0	1	0	13
17	Dr. Bhupinder Chaudhary	7	1	1	14	1	0	0
18	Dr. Darshan G Vyas	10	0	0	8	0	0	0
19	Dr. Devsinh B Rathva	8	3	1	7	2	1	32
20	Dr. Dilip C Patel	9	2	3	29	2	11	0
21	Dr. Gargi N Raval	1	0	1	3	0	0	0
22	Dr. Girish J Thakkar	0	0	0	2	0	0	0
23	Dr. H. K. Patel	9	7	0	11	0	0	0
24	Dr. Hetal S Patel	1	2	0	2	3	0	10
25	Dr. Himanshu Baraiya	7	1	2	1	1	0	5
26	Dr. Ila C Patel	21	6	2	22	0	0	6
27	Dr. J. K. Joshi	8	0	0	1	1	0	11
28	Dr. K K Patel	4	0	0	13	0	1	23
29	Dr. K L Rathod	11	0	0	4	0	0	6
30	Dr. Kokila A Parmar	49	0	3	16	0	0	0
31	Dr. Nilam	18	2	0	1	0	0	0

	K. Patel							
32	Dr. Nileshkumar A Patel	3	7	0	0	2	0	4
33	Dr. Nisha Patel	7	5	0	0	1	0	0
34	Dr. Nishith Bhatt	10	0	1	7	4	0	14
35	Dr. Nishith Dharaiya	28	2	9	8	4	12	12
36	Dr. R M Patel	7	6	0	3	0	0	0
37	Dr. Rajesh Patel	19	8	8	22	9	25	14
38	Dr. Roshan V Agrawal	8	5	0	0	2	0	0
39	DR. Rupesh Patel	14	2	0	13	0	0	0
40	Dr. Sangeeta S Sharma	46	0	2	14	0	0	0
41	Dr. Sanjay M Dave	4	1	4	12	2	0	3
42	Dr. Shakuntala Patel	7	0	0	0	0	0	0
43	Dr. Shirish Patel	14	2	1	1	3	0	0
44	Dr. Shreyash A Bhatt	31	4	2	10	0	2	10
45	Dr. Smita B Vyas	27	5	1	27	3	29	11
46	Dr. Tapas Chakrabarti	0	4	0	0	0	0	30
47	Dr. V. G. Chaudhary	6	0	0	7	1	0	14
48	Dr. V. H. Upadhyay	6	3	0	3	0	0	16
49	Dr. Vipin Soni	0	0	0	0	0	0	0
50	Modi Jayeshkumar N	2	0	0	3	3	0	0
51	Mr. Anand A Patel	1	0	0	2	7	0	0
52	Mr. Ashish Raval	0	0	0	0	0	0	0
53	Mr. Bharat D Prajapati	8	1	0	8	9	0	0
54	Mr. Bhaskargiri R. Goswami	0	0	0	0	0	0	0
55	Mr. Darshan	0	0	0	0	0	0	0

	Patel							
56	Mr. Deliya Mitul	16	9	3	11	7	0	0
57	Mr. Nimesh Bhojak	4	1	0	8	2	0	0
58	Mr. Niramalsinh P Jadeja	0	0	0	0	0	0	0
59	Mr. Sushman Sharma	1	0	0	0	0	0	0
60	Mr. Jay Y Trivedi	6	0	0	8	5	1	0
61	Prof. J J Vora	32	0	2	7	0	8	0
62	Prof. Mahendra B Prajapati	4	0	0	16	2	0	0
63	Rajput Alpa C.	0	0	0	0	0	0	0
64	Smt. Sumanben A Thakker	2	0	0	0	0	0	0
65	Tandel Sudhirkumar H	10	1	1	1	4	0	10
66	Trivedi Kavita A	5	0	1	0	0	1	0
67	V. R. Chaudhary	2	0	0	0	1	3	14
68	Vishal H Bhemwala	0	0	0	4	2	4	0

3.4.3 Give details of (Individual/faculty member response is required)

* faculty serving on the editorial boards of national and international journals

Many of our faculty members are serving on editorial board in national and international journals

* faculty serving as members of steering committees of international conferences recognized by reputed organizations / societies

Some of our faculty members has served as steering committee member

3.4.4 Provide details of research awards received by the faculty and students

Research Excellence Award Period (2011-13)

First Prize :

Dr. Ashish Patel [Highest Number of Research Project]
Dr. Ashish Patel [Highest Grant for Research Project]
Dr. Ashish Patel and his Students
Dr. Manoj Lodha and his Students
Dr. Nishith Dhariaya and his Students
Dr. Ashwin Modi [Highest Number of Research Publication]

Second Prize:

Dr. Nishith Dhariaya [Highest Grant for Research Project]
Dr. Rajesh Patel [Highest Number of Research Project]
Dr. Shirish Patel [Highest Number of Research Publication]
Ms. Nilam Patel [Highest Number of Research Publication]
Mr. Mitul Deliya [Highest Number of Research Publication]

* national and international recognition received by the faculty from reputed professional bodies and agencies

Dr. S.A.Bhatt: Taylor & Francis (Book Reviewer)
Dr. Nishith Dhariaya : Chair Person, IUCN Sloth bear Expert Team

3.4.5 Indicate the average number of successful M.Phil. and Ph.D. scholars guided per faculty during the last four years. Does the university participate in *Shodhganga* by depositing the Ph.D. theses with INFLIBNET for electronic dissemination through open access?

Yes, since June 2012, University participates in Shodhganga by depositing the Ph.D. theses with INFLIBNET for electronic dissemination through open access. University has signed MOU with INFLIBNET for Shodhganga & Shodhgangotri.

Details of M.Phil successful students

Year	Total
2009-10	196
2010-11	135
2011-12	96
2012-13	307
2013-14	271

Details of Ph.D successful students

Year	Total
2009-10	72
2010-11	146
2011-12	177

2012-13	112
2013-14	73
2014-15	72

3.4.6 What is the official policy of the university to check malpractices and plagiarism in research? Mention the number of plagiarism cases reported and action taken.

Official Committee has been constituted under BUTR to check the malpractices and plagiarism. University has decided to purchase licensed software of plagiarism and all thesis to be submitted after December 2014 to be scrutinized through this software.

3.4.7 Does the university promote interdisciplinary research? If yes, how many interdepartmental / interdisciplinary research projects have been undertaken and mention the number of departments involved in such endeavours? (Details)

Dr. Ashok & Dr. P.J.Bhatt for a Student of Ph.D.
 Dr. P.J.Vyas & Dr. Rajesh Patel
 Dr. Sangita & Dr. Rajesh Patel
 Dr. H.V.Rao & Dr. Rajesh Mehta

Yes, University promotes interdisciplinary research and collaborations with national/international institutes & industries, and therefore, the eachers of the same and different departments submit research projects to various funding agencies.

3.4.8 Has the university instituted any research awards? If yes, list the awards.

Yes, Research Awards are instituted under the following category.
 Highest Number of Research Publications,
 Highest Number of Research Projects,
 Highest Grant mobilized through Research Project.

3.4.9 What are the incentives given to the faculty for receiving state, national and international recognition for research contributions?

The range of Seed Money/Start -up Grant to the Faculty members is between Rs. 25,000 to Rs.2,00,000
 The maximum limit of Seed Money/Start-up Grant to Ph.D/M.Phil aspirants is Rs. 5,000.
 TA/DA & Study Leave are also provided.

3.5 Consultancy

3.5.1 What is the official policy of the University for Structured Consultancy? List a few important consultancies undertaken by the university during the last four years.

The university encourages consultancy the details of which are given below.

Dr. Ashwin Modi From the Department of commerce and management has got a consultancy project from Ministry of Consumer Affairs, New Delhi on “A study on Consumer Satisfaction from Healthcare organizations : Promoting Healthcare Consumerism at Gujarat”.

3.5.2 Does the university have a university-industry cell? If yes, what is its scope and range of activities?

Yes, the office of the University-Industry Linkage Cell was established on April, 2014 to facilitate the development of symbiotic relationships between the University and partners from different industrial sectors. Initially, the partnerships will be aimed to support the newly implemented mandatory industry internships for the campus graduate, postgraduate and research programs. The aim of University-Industry Linkage cell is to act as a dynamic liaison unit with industry counterparts in order to identify opportunities to develop innovative solutions for technological and industrial problems.

3.5.3 What is the mode of publicizing the expertise of the university for consultancy services? Which are the departments from whom consultancy has been sought?

University has prepared detailed consultancy policy

3.5.4 How does the university utilize the expertise of its faculty with regard to consultancy services?

University has prepared detailed consultancy policy

3.5.5 List the broad areas of consultancy services provided by the university and the revenue generated during the last four years.

Recently received project from Ministry of Consumer Affairs, New Delhi

3.6 Extension Activities and Institutional Social Responsibility (ISR)

3.6.1 How does the university sensitize its faculty and students on its Institutional Social Responsibilities? List the social outreach programmes which have created an impact on students' campus experience during the last four years.

Regular In-Campus Events

Blood Donation Camps

Aids Awareness Camps

Thelesemia Prevention Camps

Legal Literacy Camp on Women Empowerment Camps

Yoga Camps

Non Formal Education for School Drop-outs

Other Societal Activities

Girl Child education Promotion in Villages

Awareness programme in remote villages to parents to send their children for Higher Education

Plantation Programmes in Villages

Sports & Cultural Activities

Tournament on Table Tennis, Hand Ball, Badminton, Basket Ball, Wally Ball, Kabaddi, Hokey, Cricket, Athletic Meet

Youth Festival

Music, Drama, Dance, Folk Dance, Painting, Clay Modeling, Story writing Etc

Society for Environment Protection

Workshop on Biodiversity Conservation (Jointly organized by Wildlife Training Division, Gandhinagar)

Desert Exploration and Tracking

Hands on Training on Snake Handling - I

Jessore Expedition

Camp Water bird census in Patan District Vulture Conservation Action Plan

State level Summit on Nature Conservation Organized by Gujarat Conservation Groups

State level Training on Biodiversity Assessment

Snake awareness program in Eklavya Residential Schools in Tribal area of Gujarat

3.6.2 How does the university promote university-neighbourhood network and student engagement, contributing to the holistic development of students and sustained community development?

The university is actively considering students engagement and their development by conducting various programmes within campus, the university conducts such programmes under the banner of "Inspire". The university has received sponsorship of Rs.32.5 lakhs from Department of Science and Technology, New Delhi.

The objective of programme is to aware students about basic science and to increase their interest towards science, and there by ensuring student's development.

Dissemination of Information: The faculty is actively involved in dissemination of knowledge and information not only in their respective academic interest areas, but also in areas of national and global importance. Expert lectures on diverse subjects are delivered by the faculty in various institutions. Important national / international events like World AIDS Day, Environment Day, Women Day, Van Mahotsav, Ozone Day, Science Day, Population Day, World Wetland Day, Wildlife Week and Mothers Day are regularly observed by the university. Various departments also actively contribute to disseminate knowledge on sustainable technologies for conservation and management of natural resources.

Health and Nutrition: The Department of Life-Science, Biotechnology & Department of Hospital Mgt. arranges several camps for health check-up, health awareness, nutrition and life style, Blood donation along with blood testing. It propagates vital information on these issues for the benefit of the university community and general public, particularly in rural areas. The Departments also arrange training for the students on mental health check-up and behavioral problems & aberrations.

Gardi Chair Activities:

Smt. Vidyaben Deepchandbhai Gardi Chair was established through the financial support of Shri Deepchandbhai Gardi in Hem. North Gujarat University Campus to help prepare the students of North Gujarat to successfully compete in national and state level examinations like UPSC, GPSC, NET, SLET, etc.

The Gardi Chair was official inaugurated on May 17, 2011 by Hon. Dr. D. Purandeswari (Minister of State For Human Resource Development) and Hon. Prof. Vasuben Trivedi (Minister of Higher & Technical Education, Women & Child Development, Gujarat State).

No	2011 Activity	Student
1	GPSC Coaching	100
2	GCET Coaching	19
3	BACK PO Coaching	38
4	NET Coaching	117
5	CAT Coaching	62
6	GCET Coaching	45
7	TAT Coaching	18

8	Career Induction Camp Seminar	100
9	Rising on Horizon SeMinar	90
Total Student		589

No	2012 Activity	Student
1	GPSC Coaching	41
2	NET Coaching	130
3	TET(PTC) Coaching	130
4	TET(PTC) Coaching	76
5	Sub Registrar Coaching	130
Total Student		507

No	2013 Activity	Student
1	GPSC Coaching	68
2	NET Coaching	14
3	TET Coaching	88
4	Slet Coaching	73
5	Spipa Coaching	34
6	UPSC Coaching	46
7	Abhimnyu Award	5013
8	Rising on Horizon Seminar	137
9	IAS Awareness Program Seminar	213
10	Chanky Award	288
Total Student		5974

NO	2014 Activity	Student
1	GPSC Coaching	145
2	NET Coaching	70
3	TET Coaching	89
4	Slet Coaching	38
5	Talati Coaching	42
6	Army Work shop	12
7	Bin Sachiyalay Coaching	31
8	Pre Abhimanyu Comparative Exam Preparation Seminar	4160
9	RTI Seminar	400
10	PATAN VISENI Quiz	150
11	Pathfinder Seminar	56
12	GPSC Awareness Seminar	184
13	IBPS Awareness Seminar	21
Total Student		5137

Gardi Chair Vision & Mission

❖ Vision

The vision of the chair is to create a community of students who have evolved as competitive individuals with innovative ideas.

❖ Mission

- To Shape, sensitize and inculcate competitive approach in students.
- To equip students with knowledge and skill for higher education, research, job and administrative carrier building.
- To stimulate entrepreneurship passion.
- To integrate existing resources for career building.
- To find new sources in inherent assets for sustainable development.

3.6.3 How does the university promote the participation of the students and faculty in extension activities including participation in NSS, NCC, YRC and other National/ International programmes?

NSS office organizes various shibir for provides training to students to enable them to contribute in their respective ways to various community service activities. These volunteers run cleanliness and other social service campaigns in both rural and urban areas from time to time.

Applied for NCC unit

3.6.4 Give details of social surveys, research or extension work, if any, undertaken by the university to ensure social justice and empower the underprivileged and the most vulnerable sections of society?

HDI Project: Dr. Manoj Lodha

Pilot Project for Patan District : HDI

Women Cell has been established to provide legal advice & organized legal awareness programme.

University has facilitated free residential facilities in university hostels.

Dr. Babasaheb Ambedkar Chair is working for up liftment of Scheduled Caste students.

3.6.5 Does the university have a mechanism to track the students' involvement in various social movements / activities which promote citizenship roles?

Yes, the record of involvement of the on-roll students in

various social activities is maintained by the respective departments and Co-ordinator/Dean Students Welfare and NSS Coordinator. Besides, most of the departments have formed a University Alumni Association. The outgoing students are encouraged to register as members of the Association

3.6.6 Bearing in mind the objectives and expected outcomes of the extension activities organized by the university, how did they complement students' academic learning experience? Specify the values inculcated and skills learnt.

Besides delivering knowledge for career development, the university promotes the inculcation of values in the students to make them good human beings and responsible citizens.

- They become sensitive to environmental protection, national integration and a host of other social issues.
- They become aware of their civic duties like maintaining cleanliness on the campus and not polluting the environment and the city. They are also sensitized about the virtue of donating blood which saves many lives.

3.6.7 How does the university ensure the involvement of the community in its outreach activities and contribute to community development? Give details of the initiatives of the university which have encouraged community participation in its activities.

As per 3.6.2 The Department of Life Science, The Co-ordinator of NSS & Student Welfare, The Department of Hospital Management, The Department of Social Work, The Department of Journalism and other departments of the university do reach out to the community in their respective ways , for example:

- Red-Ribbon Programme is organized to educate the community about AIDS
- The university celebrates the Environment Protection day
- The university celebrates the Women Empowerment Day

3.6.8 Give details of awards received by the institution for extension activities and/contributions to social/community development during the last four years.

Year : 2012-13

N.S.S. Voluntary

Boys	Girls	Total
5802	4603	10405

No. of Afiliated Colleges join in N.S.S

DISTRICT	COLLEGE
Sabarkantha	29
Banaskantha	22
Mehsana	24
Patan	09
Gandhinagar	02
Total	86

Regular Activities :-

1. Plantation.
2. Thelesemiya.
3. Blood Donation.
4. Thelesemiya & Blood Group Testing.
5. Sahid Din Blood Donation Camp.
6. Malnutrition related lecture.
7. HIV & Rehabilitation Programme.
8. Eradication of Drug abuse awareness Programme.
9. Free Eye Check up Camp.
10. Rakshabandhan.

The above mentioned Regular Activities are held by Various Colleges on regular basis.

Special Shibir :-

1. Cultural Programme.
2. Public awareness Wall slogan.
3. Superstitions Prevention & Beti Bachavo campaign.
4. Garba, Dance.
5. Animal Health Diagnostic Centre.
6. Maintaining the Health of the Environment.
7. Child Marriage evils (Drama).
8. Padyatri Seva Camp.
9. Fire Extinguisher demonstration of Travel Under Disaster Management.
10. Musical Evening.

The above special activities are held by various colleges 7 days workshop/shibir camp is organized on several issues.

Shibir at the University Level :-

1. Celebration of N.S.S Day:-

Pramukh Swami Science & H.D. Patel Commerce College, Kadi.
Dated on 24/12/2012 organized one day Shibir. No. 130 Students (boys & Girls) from different colleges attended the shibir.

2. Yuva Leadership Training Shibir:-

R.M. Parajapati Arts College, Satlasana. Dated 9,10,11 February 2013. Organized 3 days shibir. Total 60 Volunteer (Boys & Girls) from different colleges attend the shibir. In the shibir Training for Yuva Leadership Lecture deliver by Expert and other Cultural Programme.

3. Water Accumulation Awarers Shibir :-

Arts & Commerce College, Radhanpur dated on 16,17 February (Two Days) Total 70 Volunteers (Boys & Girls) Information provide to Students Riddle in Water in the Desert. Area & raining Water for Storage.

4. Natural/Artificial Wisaster Training Shibir :-

Sabar Gram Seva Mahavidhyalaya Sonasan, dated on 21,22 February 2013 organized two days Total 56 voluneer's Boys & Girls from university, college participated in programme. During the shibir Provide Information to Volunteers.

1. Health Service provide by Govt. like 108 ambulance service.
2. Industrial Safety.
3. Change of Climate.
4. Emergency Medical Treatment etc..
- 5.

5. Environment Protection Training Shibir :-

Science & Commerce College, Palanpur, dated 15,16 March 2013. organized two days No. of 49 Volunteer Boys & Girls from various colleges

Demonstration on Field Trip nearest Forest area for the Students, Effect on Environment of Water, Site & Misfortune of Water, Responsibility for Water of Person. The above information Provide to Students by experts.

Zonal Level Programme :-

1. Pre- R.D. Camp:-

Republic Day Pared Camp at Nagpur, 27th October to 5 November 2012.

Raval Manishaben Maheshbhai, M.N.College ,Visanagar.

State Level Programme :-

1. **Training for 31 N.S.S Programme Officer :-**
In Various College at Sadra During Period of 24 October 2012 to 28 February 2013.
2. **Rashtra Katha :-**
Date : 30/12/2012 to 06/01/2013, Vaidik Mission Trust, Pransala (Rajkot) participated N.S.S. Students in Various Colleges.
3. **Red-Ribin Club :-**
At University Level Gujarat Aids Control Society, Ahemedabad.
Purpose of HIV/Aids and Blood Donate Programme in University,
Diff. Department.

National Level :-

1. **Tot on Gender Equity :-**
Rajiv Gandhi Institute of youth Development, Peramdur, Date: 1st to 7th December 2012., J.P Nayak Centre for Education & Development at Pune., 7 Day Training Period.
Programme Officer : A.D. Parmar, V.R.Patel Commerce College, Mehsana.
2. **North Eastern Festival :-**
Govt. Of Arunachal, Itanagar, 7th to 9th November 2012., 6 Participants Of N.S.S Voluntary, Arts College, Modasa.
3. **National Service Skill Development Schem :-**
Meeting attend at Bombay, Programme Officer Dr.J.D. damor, Hemchandracharya Northa Gujarat University, Patan. Date 28 January 2013.
4. **Adventure Camp :-**
14th June to 23rd June 2012 at Shimla (Narkanda) Mahila Arts College, Nardipur. 2 Girls , Arts College Shamlaji 2 Boys.
5. **Inter state Youth Exchange Programme :-**
14th March to 23rd March 2013 Madhurai (Tamilnadu), B.C.A College Berana Himmatnagar (2 Boys), M.N. College, Visanagar (2 Girls).
6. **Youth in Poverty Elivation Traninng Prgramme :-**
National Institute of Rural Development at Hyderabad, 28 to 31 January 2013, Dr. J.D.Damor, Progamme co-ordinator Participate.
7. **Human Development Index :-**
State Govt.'s Co-ordination,
Arts College, Shamlaji.
Arts & Commerce College, Bhiloda.

Arts College, Rajendranagar.
Dist- Banaskatha,
Ta. Bhiloda's 39 Villeges Survey on mobile.

3.7 Collaboration

3.7.1 How has the university's collaboration with other agencies impacted the visibility, identity and diversity of activities on campus? To what extent has the university benefitted academically and financially because of collaborations?

- University has signed MOUs with different Institutions/Universities and Industries.
 - MOU with Inflibnet resulted in Grant of Rs. 25 lac.
 - MOU with GSBTM resulted in Academic benefits
 - MOU with CIMS Hospital & Shalby Hospital : benefitted through Placements & Internship.

3.7.2 Mention specific examples of how these linkages promote

*** Curriculum development**

Curriculum development: The linkages with the academic and research institutions enable the faculty to keep abreast with the latest developments in their respective areas of interest/ specializations. It helps the faculty to benchmark their course curricula with those of the other leading institutions. It enables the students to carve a distinctive niche for themselves.

Internship: The linkages with the academic and research institutions provide opportunities to the students of the university to work with leading scientists in their respective areas of research interest. These enable the students to complete their projects. The university has signed MoUs with leading institutions to this effect.

On-the-job training: Faculty exchange and development: All the current institutional linkages with the university primarily entail collaborative research. Accordingly, the faculty comes across newer ideas and techniques to improve their teaching skills and research endeavors. This helps in generation and dissemination of knowledge which gets refined and enriched in the process both qualitatively and quantitatively.

3.7.3 Has the university signed any MoUs with institutions of national/ international importance/other universities/ industries/corporate houses etc.? If yes, how have they enhanced the research and development activities of the university?

- CIMS Hospital
- Shalby Hospital
- 108 GVK EMRI
- Abellon Clean Energy

- Geer Foundation
- De Mont Ford University
- California State University
- Georgia University
- Inlibnet Centre
- Kadi Sarva University
- Gujarat University
- Bhutan University
- S.P.University

3.7.4 Have the university-industry interactions resulted in the establishment /creation of highly specialized laboratories / facilities?

The university-industry interactions have not yet resulted in the establishment / creation of highly specialized laboratories / facilities.

Any other information regarding Research, Consultancy and Extension, which the university would like to include.

CRITERION IV: INFRASTRUCTURE AND LEARNING RESOURCES

4.1 Physical Facilities

4.1.1 How does the university plan and ensure adequate availability of physical infrastructure and ensure its optimal utilization?

Physical facility augmented in university campus. Financial resources are mobilization of resources through SF courses. Now onwards we celebrate the grand event youth festival in university premises and optimally using the convention halls and other hostel facility of university.

4.1.2 Does the university have a policy for the creation and enhancement of infrastructure in order to promote a good teaching-learning environment? If yes, mention a few recent initiatives.

University has always ensured to create / enhance infrastructure to promote good teaching – learning environment.

The university has taken several initiatives to promote good teaching learning environment which are as follows:

- (i) Construction of state of art departmental building for Master of Hospital Management Programme.
- (ii) Construction of state of art departmental building for Bachelor degree in Architecture Programme.
- (iii) Construction of additional hostels for boys and girls. Total two more hostels for boys and one more hostel for girls have been constructed by the university. This enables students to stay on the campus and save their time and energy which can be used for improving their knowledge and learning.
- (iv) Construction of Convention Hall which comprises of three different auditorium halls having capacity of 800, 350 and 150 persons respectively. The university already has two other auditorium, Kilachand Rangbhavan and Gandhi Smruti hall which have capacity of 450 and 200 persons respectively. As a result of which the university is now well equipped to organize all their programmes like seminars/conferences, youth festival, cultural programmes of the university as well as of the affiliated colleges. Some schools of Patan city are also organizing their cultural programme in the university auditorium hall. These halls are utilised by government agencies like Election commission, DDO office, office of the

Collector, and such other for the purpose of meeting or their awareness programme for the benefit of the ordinary citizens.

4.1.3 How does the university create a conducive physical ambience for the faculty in terms of adequate research laboratories, computing facilities and allied services?

For every faculty appropriate and suitable environment is basic need so that they can improve their performance in academic field and in research. The university is committed to provide such environment to their teachers so that they are motivated to conduct research. The university has shown growth in their research activities over the past five years as compared to the preceding five years.

Adequate laboratory facilities are available in the departments of Life Sciences, Chemistry, and Physics & Electronics. Apart from these, the university has established Central Instrument Facility for the researchers.

The faculties of every departments are provided latest computers and printers along with internet facility. Separate and spacious rooms are provided to each faculty in every department.

Following table shows instrument facilities available in departments of the university:

Sr.	Name of departments	Name of instruments	Brand make	Price(Rs.)
1.	Department of Sanskrit And Bhartiya Vidya	1-Overhead Projector	1-Epson	65,000/-
2.	Department of English	1-Xerox machine	Canon iR 2318	Not available
		3-Overhead Projector	1-Epson, 1-In focus 1-Panasonic PT-P1 SDEA (Small)	Not available
		5-Printer	2-Canon LBP 2900 2-Epson Stylus TX111 1-Hpdeskjet 5550	Not available
		2-Sound System	2-MIPRO MR 515/525, 2-Handheld 2-Headset	Not available
3.	Department of Commerce And Management	5 – Projectors	EPSON	4,85,000/-
		1 – Photocopy Machine	Canon	1,65,000/-
4.	Department of Chemistry * Subjected To University Approval	TGA-DSC.1	Mettler toledo	3379699/-
		CHNS Analyzer	Elementer Gmbh	2675805/-
		Density&Sound velocity meter	Anton paar	1700544/-
		HPLC	Elico	796000/-
		Gas Chromatography	Bruker	1097733/-
		FTIR Spectroscopy	Bruker	978226/-

		UV Visible Spectrophotometer	Shimadzu	415000/-
		Magnetic Balance(Faraday's)	Polytronic Corp	825000/-
5.	Department of Mathematics	1-Overhead Projector	1-Epson	65,000/-
6.	Department of Life Sciences	1-Overhead Projector	1-Epson	65,000/-
7.	Department of Computer Sciences	12- Projectors	--	Not Available
		Sun solaris server		
		HP unix Server		
		12- Printers		
8.	Department of Physical Education	Ultra Valet Therapy Inst.	--	--
		Ultra Sound Therapy Inst.	--	--
		jeem Inst.	--	--
		Ground Inst.	--	--
9.	Department of Education	1-Overhead Projector	1-Epson	65,000/-
10.	Department of Pharmaceutical Science	UV-Visible spectrophotometer	Shimadzu	415000
		Spectrofluorimeter	Shimadzu	895000
		Brookfield Viscometer	Veego	160000
		Weighing balance	Shimadzu	141905
		Stability chamber	Remi	268576
		Tablet compression Machine	Corwte	328570
		Tablet Coating Pan	Memoze	152381
		Dissolution Apparatus	Labindia	204744
11.	Institute of Architech	1-Overhead Projector	1-Epson	65,000/-
12.	Center of Indian Diaspora & Cultural Studies	1-Xerox machine	1-Canon iR 232OL	Not available
		1- Overhead Projector	1-Epson	Not available
		4-Printer	1-Canon IBP 2900B 2-HP DeskJet 3940, 840C 1-HP LaserJet 3050	Not available
		2-Sound System(Wireless Amplifier	2-AHUJA 2-Amplifier 2-Mike	Not available
13.	R. J. Computer Center	1-Overhead Projector	1-Epson	65,000/-
14.	Yoga Centre			
15.	Department of Hospital Management	3-Overhead Projector	Epson	1,95,000/-
16.	Department Library And Information Science	LCD projector	Panasonic	5000/- approx
17.	Department of Social Work	Computer	Acer	Purchase by University
		Projector	Sony	Purchase by University

18.	Department of Biotechnology	PCR	EPPEN DROF	2,25,000/-
19.	S. K. College of Business Management	5 – Projectors	EPSON	4,85,000/-
20.	PG Diploma in Industrial Sefty	1.Laminar Airflow (LAF)	Diamond	80,953/-
		2. Dust Sampler	Instrumex	1,68,574/-

4.1.4 Has the university provided all departments with facilities like office room, common room and separate rest rooms for women students and staff?

The university has provided ample office room to all departments. The university has provided separate rest room/common room for female students in all departments.

4.1.5 How does the university ensure that the infrastructure facilities are disabled-friendly?

The university has designed its new infrastructure projects in such a way as to make them disabled-friendly.

4.1.6 How does the university cater to the requirements of residential students? Give details of

- Capacity of the hostels and occupancy (to be given separately for men and women)
- Recreational facilities in hostel/s like gymnasium, yoga centre, etc.
- Broadband connectivity / wi-fi facility in hostels.

The Following table shows the details of university hostel:

Hostel Accommodations	Area in Smt.	No. of Room	No. of Students	No. of Students Allotted
U.G. Boys' Hostel	3588	72	216	94
P.G. Boys' Hostel	4054	68	204	190
Tribal Boy's Hostel	4727	96	192	144
U.G.C Ladies Hostel-1	2030	31	93	120
U.G.C.Ladies Hostel - 2	2418	33	99	139
Tribal Ladies Hostel	2274	32	96	59

Hostel with dining hall facility & multipurpose hall

Boy's Hostel				Ladies Hostel		
	Room	Capacity	Area in Sq.mt.	Room	Capacity	Area in Sq.mt.
OLD	72	216	3588	31	93	2030
TDD	68	204	4054	32	96	2418
PG	96	192	4727	33	99	2274

The occupancy generally remains full in all the hostels. Since the TDS level in the water in this region is much above WHO prescribed standard, the university has installed RO plant in each hostel to provide better quality water to all hostel students. The university has also provided geyser facility in the hostel.

There are no recreational facilities at present in the hostels for students. But, students of the hostel can access gymnasium and yoga centre facilities in the university at any time. Entry to gymnasium and yoga centre for university hostel students is free. The university is planning to install television sets in all hostels. There is no broadband and wi-fi facility in hostel for students at present. The university has plans to make the entire campus wi-fi and computer centre of the university has already initiated the process.

4.1.7 Does the university offer medical facilities for its students and teaching and non-teaching staff living on campus?

Yes, the university offers medical facility for its students and teaching and non-teaching staff living on the campus. The university has one health centre and one qualified doctor is appointed in the health centre. Apart from it, the departments also keep first aid kit. In case of emergency service of 108 ambulance facility is also available.

4.1.8 What special facilities are available on campus to promote students' interest in sports and cultural events/activities?

To promote students interest in sports and cultural activities the university has established Board of Sports and Board of Extramural Studies. Both boards organise various activities in the university on regular basis. The annual schedule is also sent to various colleges and departments at the beginning of the year. Detail about various events conducted by the university is also available on university website. The link for the same is [http://www.ngu.ac.in/ department/](http://www.ngu.ac.in/department/)

[SPORTS%20COMPLEX/SPORTS%20COMPLEX.htm](#)

The winners of the sport events are sent to play at Inter-University level, State level, Zonal level and National level. University coach and Physical Education department of the university ensures promotion of sports in the university and affiliated colleges.

The competitions for the following games are covered every year in various events for boys and girls:

- | | |
|-------------------------|------------------------|
| 1. Archery, | 15. Judo, |
| 2. Athletics, | 16. Kabbadi, |
| 3. Badminton | 17. Kho-kho, |
| 4. Chess, | 18. Kusti, |
| 5. Ball Badminton, | 19. Netball, |
| 6. Basketball, | 20. Power Lifting, |
| 7. Best Physique, | 21. Softball, |
| 8. Boxing, | 22. Swimming, |
| 9. Cricket, | 23. Table Tennis, |
| 10. Cross country race, | 24. Tennis singles & |
| 11. Cycling, | doubles, |
| 12. Football, | 25. Volleyball, |
| 13. Handball, | 26. Weightlifting, and |
| 14. Hockey, | Yoga |

The university has following ground and indoor facilities for sports:

- | | |
|----------------------|----------------------|
| 1. 400 meter Track, | 7. Tennis Court |
| 2. Football Ground | 8. Basket Ball Court |
| 3. Ground for Hockey | 9. Badminton Court |
| 4. Handball | 10. Softball Field |
| 5. Volleyball Court | 11. Judo & Kusti |
| 6. Khokho & Kabbadi | 12. Gymnastic |

To promote sports among the university employees (teaching and non-teaching) the university has sports room in the administrative building.

Following things are available:

1. Carom Board – 2
2. Table Tennis – 1
3. Chess – 2
4. Cricket Kits – 1

The university cricket team consists of young teaching and non-teaching staff. The team participates every year at state level cricket competition between universities of Gujarat.

Cultural activities are organized by the students of departments

on a regular basis. The students normally perform cultural activities in the auditorium. The university has five auditoriums for performance of such events. The university also promotes cultural activities in departments and affiliated colleges by organising Youth Festival every year. The university has following facility for promotion of cultural events and activities.

1. Gandhi Smruti Hall (Seating Capacity 200)
2. Kilachand Rang Bhavan (Seating Capacity 375)
3. Convention Hall Unit 1 (Seating Capacity 800) (Under construction)
4. Convention Hall Unit 2 (Seating Capacity 350) last stage)
5. Convention Hall Unit 3 (Seating Capacity 150) “

The winning team from each category is sent for Zonal level competition. The university has won 1st position in Elocution Competition and 3rd position in instant drawing competition at Zonal level in the academic year 2013-2014.

4.2 Library as a Learning Resource

4.2.1 Does the library have an Advisory Committee? Specify the composition of the committee. What significant initiatives have been taken by the committee to render the library student/user friendly?

Yes, the university library has an advisory committee. The chairman of advisory committee is the Vice-Chancellor of the university. Members of the advisory committee are as follow:

- (i) Dr. R. L Godara (Vice-Chancellor, HNGU)
- (ii) Dr. Dipoooba Devda (Pro- Vice-Chancellor, HNGU)
- (iii) Dr. L S Patel (Dean, Faculty of Arts)
- (iv) Dr. Lilaben Swami (Dean, Faculty of Commerce)
- (v) Dr. M B Prajapati (Dean, Faculty of Science)
- (vi) Shri K R Trivedi (Dean, Faculty of Law)
- (vii) Dr. S G Patel (Dean, Faculty of Education)
- (viii) Dr. Pinakin N Trivedi (Dean, Faculty of Medicine)
- (ix) Dr. B. A Prajapati (Dean, Faculty of Management)
- (x) Smt. Bhavnaben J Shah (Dean, Faculty of Home Science)
- (xi) Dr. Himmatsing C Rajput (Dean, Faculty of BRS)
- (xii) Dr. S A Bhatt (Head, Department of Life Science)
- (xiii) Dr. J J Vora (Head, Department of Chemistry)
- (xiv) Dr. Adesh Pal (Head, Department of English)
- (xv) Dr. D B Rathva (Head, Department of Sanskrit and Bhartiya Vidhya)

- (xvi) Dr. A R Patel (Head, Department of M. Sc. CA&IT)
- (xvii) Dr. D R Patel (Principal, Department of Art & Science College, Mehsana)
- (xviii) Dr N A Patel (Co-Ordinator, Department of Library & Info. Science)
- (xix) Dr. B K Chaudhary (Librarian, Arts College Satlasana)
- (xx) Dr. Jagdish Arora (Director, Inflibnet Center)
- (xxi) Dr. J D Damor (CAO, HNGU)
- (xxii) Dr. K A Jani (I/C University Librarian, HNGU)

The committee meets twice in a year and discusses & plans the activities of library so that the library and its resources become accessible to larger number of students and teachers of the university. Following initiative have been taken by the library committee for the benefit of students, researchers and teachers of the university:

- (i) Membership of British library. The students, researchers and teachers of the university can access resources of British Library online through its website www.britishcouncilonline.org.
- (ii) Access to delnet online resources. DELNET provides access to online international / national journals of repute in area of science/arts/commerce/management and other disciplines. Teachers and researchers can access more than 4700 journals.

4.2.2 Details of the Library building is as following:

- (i) The total area of the library building is 2486.41 sq.mts.
- (ii) Total seating capacity of the library is as follow:
 - (a) The reading hall has capacity to accommodate 160 students
 - (b) The Research hall can accommodate 60 candidates.
 - (c) The reference section can accommodate 50 students.
- (iii) Working hours (on working days, on holidays, before examination, during examination, during vacation) is as follow:

Library Office working time: 10.30 am to 6.10 pm
 Reading hall time: 8.00 am to 8.00 pm every day.
 Reading hall time: 8.00 am to 10.00 pm before & during examination period.
 Stack room time: 8.00 am to 8.00 pm every days
 Reference Hall time 10:30 am to 6:10 pm during working days of the vacation.

The Library remains close on 26th Jan, 15th Aug, and 2nd Oct.

(iv) Layout of the library showing individual reading carrels, lounge area for browsing and relaxed reading, IT zone for accessing e-resources is as below:

Library Ground Floor Plan

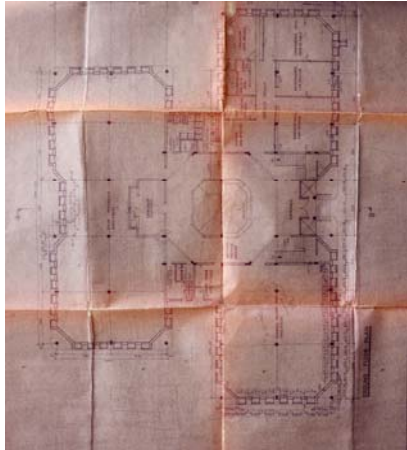

Library First Floor Plan

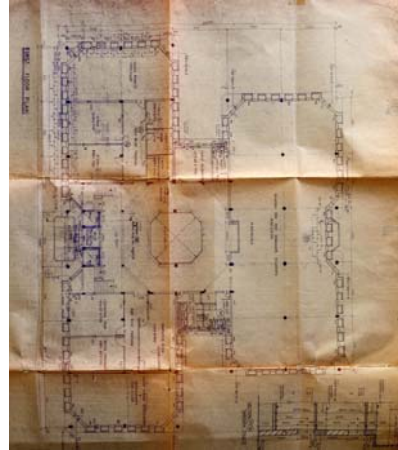

□ There is adequate sign boards present in the library; fire extinguishers are also kept in the library building.

4.2.3 Give details of the library holdings:

a) Print (books, back volumes and theses):

Books : 67,637

Ph.D Thesis: 1092

MPhil Dessertation: 1092

BackVolumers: 2336

Special Collection: 4252

b) Average number of books added during the last three years

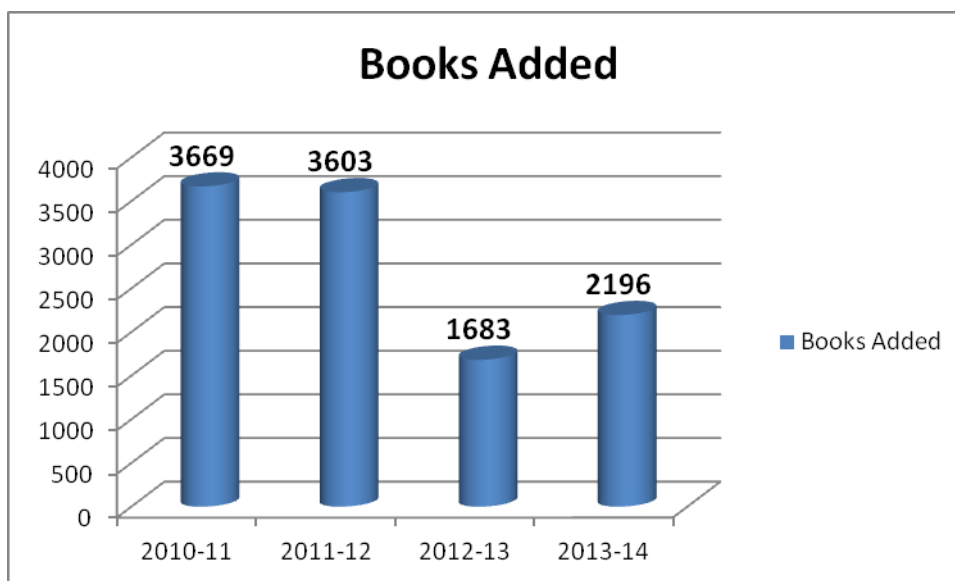

Books added in the year 2013-2014: 2195
 Books added in the year 2012-2013: 1683
 Books added in the year 2011-2012: 3603
 Books added in the year 2010-2011: 3639

- c) Non Print (Microfiche, AV) :
 Audio-Video collection: 841

- d) Electronic (e-books, e-journals):
 The university library has subscribed to e-journals through 'DELNET' and "UGC Infonet" through Infflibnet. The number of e-journals that can be accessed by the teachers and research scholars are mentioned below:

Name of Publisher	Number of Journals
American Chemical Society	37
American Institute of Physics	18
American Physical Society	10
Annual Reviews	33
Blackwell Publishing	497
Cambridge University Press	224
Emerald	29
Institute of Physics	46
Oxford University Press	202
Project Muse	407
Royal Society of Chemistry	29
Springer Link	1950
Taylor and Francis	1076

IEEE	147
Total	4705

The university also has subscribed to online database through 'DELNET' which are as follows:

Name of Publisher of database	Number of database
ISID	01
Royal Society of Chemistry	06

- e) Special collections (e.g. text books, reference books, standards, patents) : 4252
- f) **Book Banks :**
Book bank is maintained by various departments. The Computer Science department for M.Sc. (CA & IT programme), and S. K. College of Business Management for BBA and B.Com. programme has maintained book bank.
- g) Question Banks : One

4.2.4 What tools does the library deploy to provide access to the collection?

The library has modernised its operation by employing computers. Latest version of 'SOUL' is installed in the network. Students can access to network and can find things in which they are interested. Students can also find availability of book online. There are seven computers available in the library for the same.

- **OPAC**

The Online Public Access Catalog (OPAC) is available in the university library. Users can search a library catalog principally to locate books and other material available at the library. Three computers have been kept for the purpose in the library.

- **Electronic Resource Management package for e-journals**

The university library also has a cyber cafe for students. Students can access online journals subscribed by the university from the cyber café. Federated searching tools to search articles in multiple databases:

The university library uses SOUL software for searching of databases.
Library Website

There is no dedicated website of the university library. Link has been provided in the university website for library resources.

In-house/remote access to e-publications

Teachers and researchers can access e-publication in-house /remote.

User ID and Password is provided for the purpose.

4.2.5 To what extent is ICT deployed in the library? Give details with regard to

Library automation

Library work is automated. The data pertaining to book availability, issue, return etc is in the final stages of computerization. Latest version of 'SOUL' is used. Till to date data about 58,928 books have been computerized.

- Total number of computers for general access

Seven computers are available for general access to students and researchers.

- Total numbers of printers for general access

One printer is available for general access.

- * Internet band width speed

Internet band width speed in the university library is 1 mbps

- Institutional Repository

The library received the late Dr. B.J.Sandesara's personal library as a gratis. It contains about 4,252 books and some back volumes of literary and indological journals. This collection is very rich in the areas of Gujarati and Sanskrit literature, History, Culture, Jainology and Indology. The library is also planning to build a local history museum and a Hemachandracharya corner.

- Content management system for e-learning

- * Participation in resource sharing networks/consortia (like INFLIBNET)

The university library has participated in resource sharing network / consortia by joining INFLIBNET.

4.2.6 Provide details (per month) with regard to

- Average number of walk-ins

Following table shows number of students visits to library

Average number of visitors per month year wise

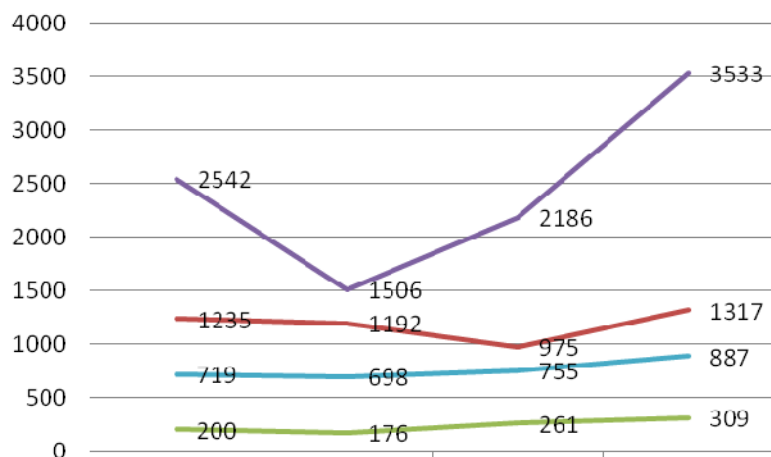

	2010	2011	2012	2013
Property Counter	1235	1192	975	1317
Cyber Cafe	200	176	261	309
Reading Room	2542	1506	2186	3533
Reference Room	719	698	755	887

➤ Average number of books issued/returned is as follow:

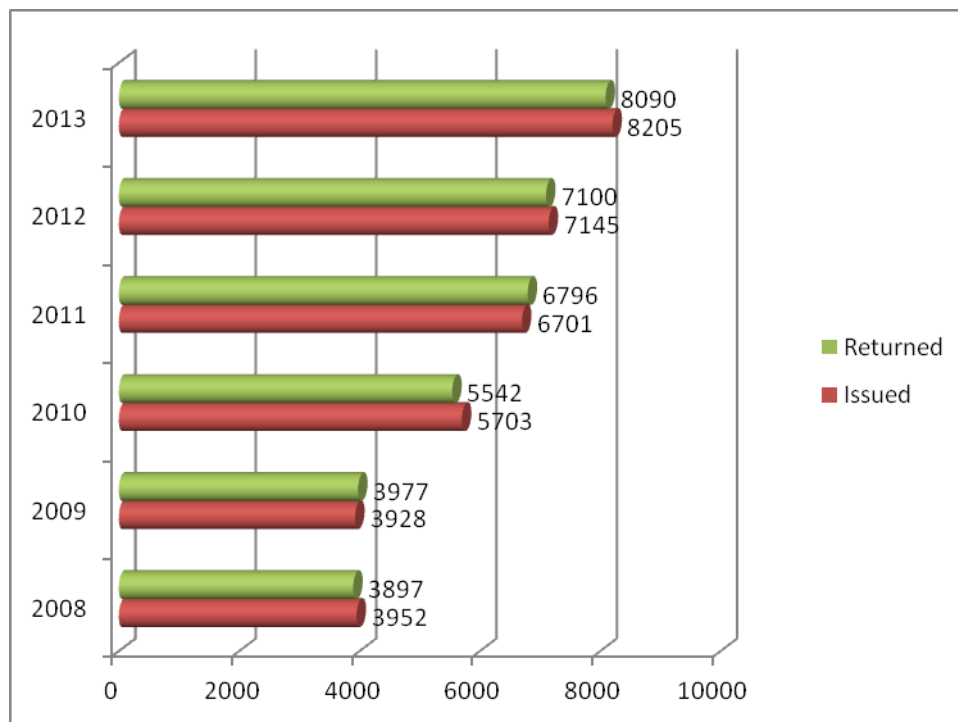

- Ratio of library books to students enrolled is as follow:

Year	Members	No. of Books	Ratio
2008-09	386	55900	144:1
2009-10	470	58712	124:1
2010-11	427	62351	146:1
2011-12	555	65954	118:1
2012-13	595	67637	113:1
2013-14	664	69832	105:1

GRAPH- Library books to students

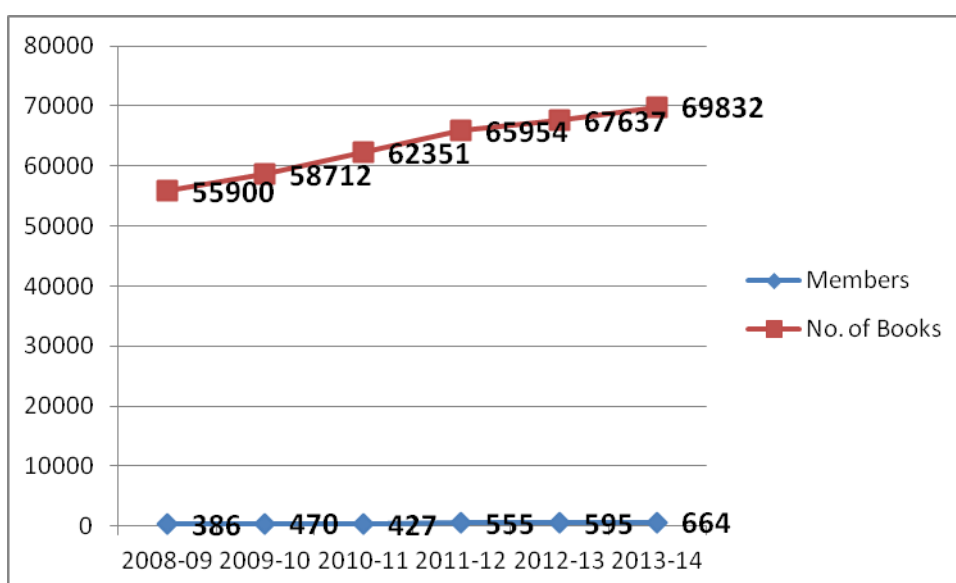

- Average number of books added during the last four years

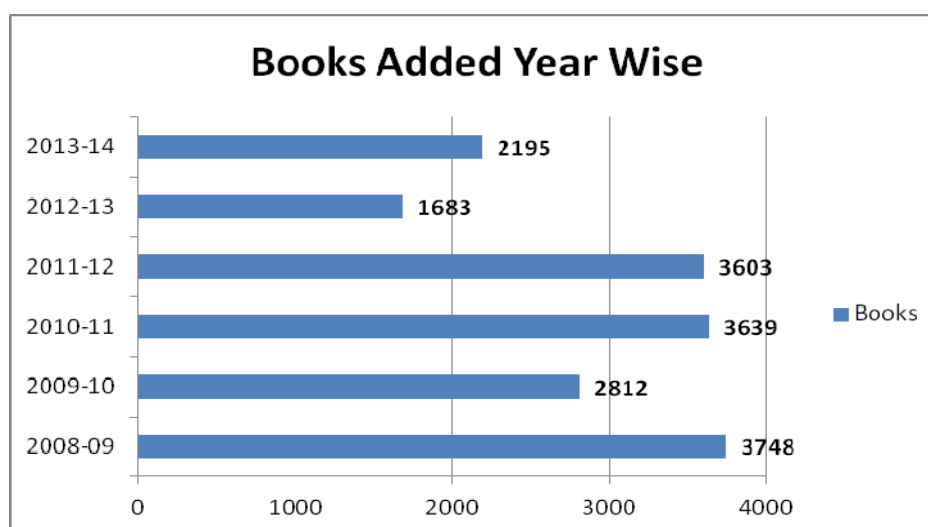

- Average number of login to OPAC

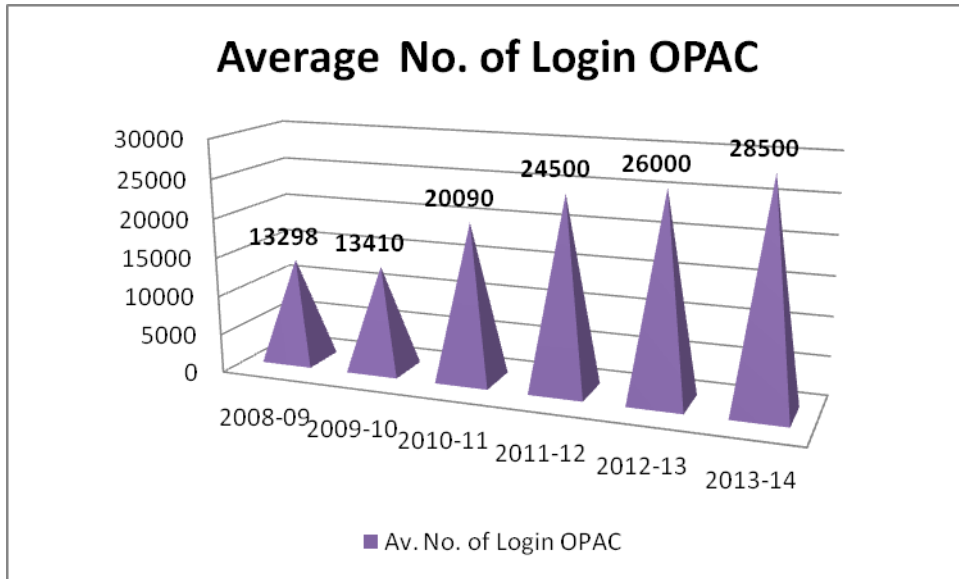

- Average number of login to e-resources

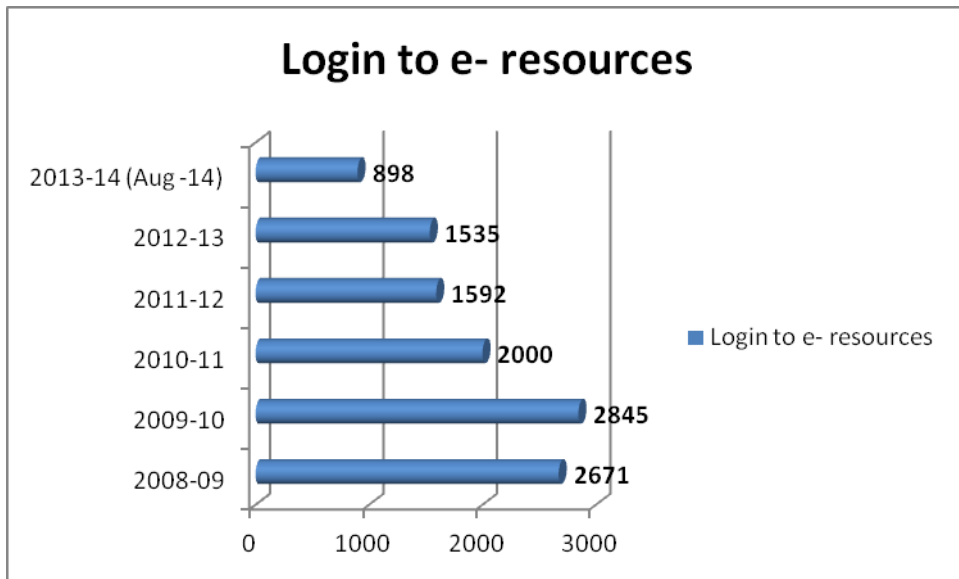

- Average number of e-resources downloaded/printed

Year	Printed
2008-09	1080
2009-10	1460
2010-11	1745
2011-12	1025

2012-13	1620
2013-14	1200

Number of IT (Information Technology) literacy trainings organized
The university library has organised following training program on IT literacy:

1. N-List
2. e-Rosources
3. Workshop for SOUL 2.0
4. Library literature and E-Journals search for students
5. How to operate Computers

4.2.7 Give details of specialized services provided by the library with regard to

- Manuscripts - Yes
- Reference - Yes
- Reprography/Scanning - Yes
- Inter-library Loan Service - Yes
- Information Deployment and Notification - Yes
- OPACS - Yes
- Internet Access – Yes
- Downloads- Yes
- Printouts - Yes
- Reading list/ Bibliography compilation - Yes
- In-house/remote access to e-resources - Yes
- User Orientation - Yes
- Assistance in searching Databases - Yes
- INFLIBNET/IUC facilities - Yes

4.2.8 Provide details of the annual library budget and the amount spent for purchasing new books and journals.

Following table shows detail of annual budget and the amount spent for purchasing new book and journals in the central library of university:

Year	Budget (Rs. Lakh)	Amt. Spent(Rs. Lakh)
2013-14	43.44	22.29*
2012-13	46.60	46.65
2011-12	37.60	26.34*
2010-11	15.50	15.50

- to be spent during five year plan.

4.2.9 What initiatives has the university taken to make the library a ‘happening place’ on campus?

1. ‘Budhvariya’ – a weekly open group discussion Forum for students. Held every Wednesday evening at 5.00 p.m.
2. Orientation for university department students.
3. ‘Vanchan Shibir’ (reading workshop) for students.
4. Debate competition for students.
5. Book fair/exhibition for students and teachers of the university.
6. Help & support from library staff to students, researchers and faculties of the departments.
7. Good reading facility and environment
8. Individual cabin like structure for reading for researchers.
9. Air-conditioned reading environment

4.2.10 What are the strategies used by the library to collect feedback from its users? How is the feedback analysed and used for the improvement of the library services?

A suggestion box is kept in the library. The students / researchers /faculty can also register complain on the university website. Complaints are immediately attended to by the concerned authority. Suggestions are also brought to the knowledge of appropriate authorities and decisions are taken based on their merits..

4.2.11 List the efforts made towards the infrastructural development of the library in the last four years.

1. Increase in the number of reading tables and chairs
2. Replacing old photo copy machine with latest and new machine.
3. Adding new latest configuration computers for students
4. Development of research room with air conditioning facility.
5. Replacing old news paper stand with new.
6. Updating facility of Property counter.
7. Installing Multimedia projector in library
8. Purchasing new cleaning machine.
9. Installing CCTV Camera in library area from security point of view.
10. Purchasing new wooden rack and iron cupboard for storing books.
11. Digitalization of “Sandesara” Collection.

4.3 IT Infrastructure

4.3.1 Does the university have a comprehensive IT policy with regard to

IT Service Management - Yes
Information Security - Yes
Network Security - Yes
Risk Management - Yes
Software Asset Management - Yes
Open Source Resources - Yes
Green Computing - Yes

4.3.2 Give details of the university's computing facilities i.e., hardware and software.

Number of systems with individual configurations

Computer-student ratio

Dedicated computing facilities

LAN facility

Yes, LAN facility is available in the university. Computers are connected through LAN in the administrative building, central library building, result centre of the university, computer science department, hospital management department, commerce & management department, R.J Computer centre, BBA department, department of mathematics and all other departments of the university where computer laboratory is available for students.

Proprietary software

The university's computer centre is responsible for hardware and software related issues. The centre keeps and maintains all proprietary software. SPSS is used by department of commerce and management, MATLAB is used by department of mathematics. Cyberoam is used by computer centre of the university.

Number of nodes/ computers with internet facility: 500

Any other (please specify)

4.3.3 What are the institutional plans and strategies for deploying and upgrading the IT infrastructure and associated facilities?

The computer centre of the university regularly previews existing computer infrastructure and suggest, if required, the upgradation of IT infrastructure and associated facilities. Also, The university departments and administrative section put up their proposal for upgradation and other IT related requirements to the computer centre of the university. The system analyst of the university then starts

the process of procurement and installation of the same.

4.3.4 Give details on access to on-line teaching and learning resources and other knowledge and information database/packages provided to the staff and students for quality teaching, learning and research.

Teachers of some departments provide information regarding online resources to students. The Department of management has subscribed to the following database/packages for students and teachers:

(i) PROWESS: It is the database of financial performance of over 27000 companies. It also provides news and other related information about these companies.

(ii) ACE Analyzer (Ace Equity): It is a database application which gives a comprehensive and analytical statistics for company information with user friendly navigation. It also provides news and other related information of various industries and companies.

(iii) Capitaline (CL2000) : It provide financial and non-financial digital database of more than 26,000 Indian companies, classified under more than 300 industries, with analytical tool.

The above database/ application are available to faculty/students and researcher of the university.

4.3.5 What are the new technologies deployed by the university in enhancing student learning and evaluation during the last four years and how do they meet new / future challenges?

The university is exploring possibilities of using latest computing technology to enhance students' learning and evaluation. Barcode stickers are also used on trial basis in B.Sc. programme.

The faculties of the university are using technology and preparing power point slides, pdf files, word files etc for dissemination of knowledge. It is also provided to students through mail so that students can use it to enhance their learning. Use of multimedia projector is also there in every department. Students are also shown subject/ topic related short films on multimedia whenever required.

4.3.6 What are the IT facilities available to individual teachers for effective teaching and quality research?

The university has provided separate cabin to every teacher. Every teacher in the university has a desktop/laptop or both along with printing and high speed internet facility in the department. Class rooms are equipped with wi-fi/wired multimedia projectors for effective teaching. IT related complaints of the teacher is immediately attended

to by the computer centre of the university. E-Journals/database is also accessible from the table of the teachers.

4.3.7 Give details of ICT-enabled classrooms/learning spaces available within the university? How are they utilized for enhancing the quality of teaching and learning?

Most of the class rooms in the university are equipped with multimedia projector. Internet facility is also available in the classroom / laboratory in some departments of the university. The auditorium of the university “Rangbhavan” is also equipped with multimedia. The university has initiated the process to make entire campus wi-fi.

4.3.8 How are the faculty assisted in preparing computer- aided teaching-learning materials? What are the facilities available in the university for such initiatives?

All teachers are given computer/printer/internet facility to prepare teaching-learning material. In the year 2013-14 university has conducted two workshops in collaboration with Microsoft for teaching and non-teaching staff of the university.

4.3.9 How are the computers and their accessories maintained?

The computer centre of the university is responsible for maintenance of computers and its accessories. It has trained manpower. The university has also given annual maintenance contract, by inviting tender, for maintenance, repairing and supply of computer and accessories. The centre purchases new one in case the part / accessories is not repairable. It also up-grades hardware/software as and when required or on the recommendation of academic/administrative department.

4.3.10 Does the university avail of the National Knowledge Network connectivity? If so, what are the services availed of?

Yes, the university is connected to NKN under NMEICT.

4.3.11 Does the university avail of web resources such as Wikipedia, dictionary and other education enhancing resources? What are its policies in this regard?

Teachers and students of the university are using web resources like Wikipedia, dictionary etc. Teachers are aware of the limitations of these e-resources and they also inform students about it and ensure that other reference material is used. The teachers, students and researchers are encouraged to use other online reference, e-journals and database, available through university website. The university has membership

of British Library, DELNET, Inflibnet and Bentham and teachers, students and researchers are encouraged to access these resources online.

4.3.12 Provide details on the provision made in the annual budget for the update, deployment and maintenance of computers in the university.

The university has separate budget head for update, deployment and maintenance of computers in the entire university. The university every year gives AMC through tender to an outside agency for maintenance of computers and peripherals in university.

4.3.13 What plans have been envisioned for the gradual transfer of teaching and learning from closed university information network to open environment?

Presently no plan is made for open environment system.

4.4 Maintenance of Campus Facilities

4.4.1 Does the university have an estate office / designated officer for overseeing the maintenance of buildings, class-rooms and laboratories? If yes, mention a few campus specific initiatives undertaken to improve the physical ambience.

Yes, the university has estate office and has appointed full time Dy. Executive Engineer and Assistant Engineer to look after the maintenance of building, class rooms, laboratories and other physical facilities. The university has taken following initiatives to improve physical ambience:

- (i) Silver Jubilee Park in the campus.
- (ii) Pond with walk path.
- (iii) Landscaping, development of grass-lawn and plantation alongside every department.
- (iv) Internal beautification of every department by providing various plants.
- (v) Maintenance of these facilities is outsourced by the university.

4.4.2 How are the infrastructure facilities, services and equipments maintained? Give details.

The estate department of the university is responsible for maintenance of electric power, plumbing, and mechanical items, furniture and fixtures. The university has recruited electrician-1, motor-man-1, plumber-1, carpenter-1 and helper-3 for maintaining infrastructure facilities. Technical staffs (lab technician) are employed for maintenance of laboratory in chemistry, life science and bio-

technology department. The university has also recruited one technical officer and technical assistant in the central instrument laboratory for maintenance of instruments. In case of major fault in the instrument, the university calls service engineer of the company.

For maintenance of landscaping, grass-lawn, university has hired gardeners through an agency. Security personnel are hired through security agency. For sanitation and cleaning of departmental buildings, hostel buildings, auditorium and guesthouse, teaching and non-teaching quarters, road and other infrastructure sweepers are also hired through an agency.

Maintenance of computers and other IT facilities is done by the computer centre. Annual Maintenance Contract is given not only for computer and accessories but also for ACs and RO plants. Complaints are registered at the computer centre in cases of breakdown and malfunctioning of computers and accessories and with estate department in all other cases.

Any other information regarding Infrastructure and Learning Resources which the university would like to include.

Many time the university auditoriums are used by other affiliated colleges and schools of surrounding areas, government and semi government agencies for educational, cultural and other activities.

The lush green campus of the university is often visited by the students of various schools of north Gujarat region.

Apart from the university library, few other departments of the university have departmental library. Department of Commerce and Management, Department of Computer Science, Department of Hospital Management and S. K. College of Business Management are having their own library. The university library / departmental library is also accepting donation in form of books.

The library of Commerce and Management department has received more than 850 books as donation from Dr. B. A. Prajapati on various management subjects' worth about Rs.2.60 lakhs. The department has specially created a place in the library known as 'Dr. B. A. Prajapati Books Corner'.

The reading room of the library is used by the people of Patan for reading, journals, newspapers and magazines. Not only students but also senior citizens attend the weekly "Budhavariya" meeting.

CRITERION V: STUDENT SUPPORT AND PROGRESSION

5.1 Student Mentoring and Support

5.1.1 Does the University have a system for student support and mentoring? If yes, what are its structural and functional characteristics?

- Academic Support and Mentoring is provided for each program which ensures academic inputs needed by students and mentor students.
- Guidance to students is provided regarding choice of specialization subject, summer training, placements, etc. Students also have faculty mentors for seminar presentations.
- University website (www.ngu.ac.in & www.hngu.net) helps student for availing of the following details
 - Academics : Admission, Syllabus, Old papers, Academic Calendar
 - Examination : Online Results, Examination Time Table
 - Facilities : UG/PG Hostel details, Health Center, Gymnasium, Sports complex
 - Formats : Examination forms, Forms for Colleges and Students and Statistical Formats.
- Student Welfare Schemes: Student welfare schemes (scholarships) are available to reserved categories students.
- Class for different competitive exams (Free of cost for reserved categories, career counseling, soft skill development, etc are available to the students. Student participation in co-curricular and extra-curricular activities is encouraged.
- The university has a career counseling and placement cell which helps to identify job opportunities and groom students for industry.
- The university has an equal opportunity cell & CASH (Committee against sexual harassment), SC/ST Cell.
- The university has a mechanism for timely redressal of student grievances. The university has gymnasium for students thus encouraging them to stay fit physically.
- University Campus has suvidha Kendra which has the following facilities for students:
 - SBI Bank – Opens zero balance a/c for students
 - Post office,
 - Employment Exchange,
 - Center of BAOU & IGNOU
 - Free Cyber café to university students, many departments have Wi-fi enabled buildings which provides free access to the students.

- Motivational mentoring through University Funds and Donations
 - Gold Medals are provided to the university toppers of all subjects.

5.1.2 Apart from classroom interaction, what are the provisions available for academic mentoring?

Academic mentoring is provided to students by a system of faculty program coordinators. Students are also mentored by faculty mentors for summer training projects, major research projects etc. Students, as part of internal assessment, are required to give Seminar presentations which they prepare under the guidance of faculty mentors. The continuous evaluation scheme of institute also ensures continuous academic mentoring.

Apart from classroom teaching, in every department remedial classes are organized under the UGC remedial classes scheme. UGC remedial classes are centrally coordinated by the coordinator and weaker students and students of SC/ST categories are mentored by the departmental faculties as well as sometimes the guest faculties as experts.

Moreover students are also sent for field work, industrial training, internship in NGOs, hospitals and concerned organizations for their academic and professional enhancement through the university.

5.1.3 Does the University have any personal enhancement and development scheme such as career counseling, soft skill development, career-path-identification, and orientation to well-being for its students? Give the detail of such schemes.

Yes, as mentioned above, the University has initiated some futuristic schemes for development of students.

1. The Programs of National Skills Development Certification (NSDC) in association with Government of India has been launched, which benefits the students of all programmes. The program is to empower the students with basic skills, so that he/she gets more exposure in the market.
2. Soft Skill Development: The university has implemented choice based credit system (CBCS) system at UG and PG level for regular assessment of the students. The assessment gives equal weightage to the written, verbal and presentation skills, which is assessed by regular presentations, seminars, assignments and internal test of the students. This process helps to identify slow learning students from the advanced learning students. The advanced learners are given opportunities to present their research work in various national and

international conferences and are also given platform to conduct market survey and research relating to corporate and social topics.

3. The Gardi Chair frequently organizing courses for personality development, communication and leadership development at a nominal cost for all university students.
4. The University conducts NET/SET Coaching and Remedial Coaching classes through Gardi Chair on regular basis.
5. The University has SPIPA nodal center for IAS/IPS residential coaching for students.
6. The Equal Opportunities Cell organizes Spoken English, Personality Development, and Soft Skills Workshops for SC/ST students on the campus every year.
7. Career Counseling Cell is formulating such courses especially for the students of PG departments.

5.1.4 Does the university provide assistance students for obtaining educational loans from banks and other financial institutions?

On campus branch of State bank of India offers zero balance account opening to all the university students and the heads of all departments help the students in their efforts.

Few departments, like department of computer science, department of commerce and management are assisting students for obtaining bank loans especially for purchase of personal computers, laptops and for abroad visits.

5.1.5 Does the university publish its updated prospectus and handbook annually? If yes, what are the main issues/ activities/ information included / provided to students through these documents? Is there a provision for online access?

University publishes e brochures as well as for the departments (Join – HNGU on www.ngu.ac.in)

Apart from this, some departments which offer professional courses also publish departmental brochures containing placement information and course achievements.

Departments are also publish their course handbooks containing detailed curriculum, academic planners, list of internal evaluation activities and reading references for the specific courses.

5.1.6 Specify the type and number of university scholarships/ freeships given to the students during the last four years. Was financial aid given to them on time ? Give details (in a tabular form) for the

following categories: UG/ PG/ M.Phil / Ph.D / Diploma / others (please specify).

University offers fee concession to toppers in some of our departments, Freeship to Children of university employee studying in various programs (zero tuition fees).

5.1.7 What percent of students receive financial assistance from state government/ central government and other national agencies (Kishore Vaigyanik Protsahan Yojana (KVPY), SN Bose Fellow, etc.)?

Year	No of students getting financial assistance from government
2013-14	1001
2012-13	1055
2011-12	996
2010-11	942

Approx 1 percent of students are getting financial assistance from central government

5.1.8 Does the university have an International Student Cell to attract foreign students and cater to their needs?

At present, the university does not have such cell, however, the University has initiated the process to attract international students for M.Phil and Ph.D. programmes.

5.1.9 Does the university provide assistance to students for obtaining educational loans from banks and other financial institutions?

The university campus is having suvidha Kendra where Bank, Post office, Rojgar Kendra, Canteen, ATM such facilities are available students take optimum benefit of such facilities, Bank (SBI) helps students to avail the educational loan and university departments helps students in documentation process.

5.1.10 What type of support services are available for

- Overseas students: No overseas student has been enrolled in the university so far.
- physically challenged / differently-abled students: The state government norms for physically challenged students are adhered to at the time of admission.
- SC/ ST/, OBC and economically weaker sections: the university follows the Gujarat Government rules for reservation of SC/ST/ OBC and weaker sections students.

- Students participating in various competitions/ conferences in India and abroad: the University provides registration fee and the logistic support as per the availability of funds.
- Health center, health insurance etc.: The University health center provides medical services at a token case fee of Rs. 1 only for university students.
- Department of life sciences organizes camps for Health checkup, Thellasemia, HIV, etc and other health related tests free of costs.
- Skill development (spoken English, Computer literacy, etc.): Gardi chair and Career Counseling Cell of the university frequently organizes skill development programmes for the university students.
- Cyber café in the central library is available at free of cost for university student.
- Performance enhancement for slow learners: UGC remedial classes scheme launched from last academic year which assists the slow learners.
- Some departments organize weekly test and improvement programmes for slow learners.
- Exposure of students to other institutions of higher learning/ corporate/ business houses, etc.
- Publication of student magazines: University library publishes its quarterly magazine “Uttara” for students.
- Apart from these, University departments like, Architecture, Life Sciences, Computer Science, etc publish their own e news letters, e journals for the concerned subjects.

5.1.11 Does the university provide guidance and /or conduct coaching classes for students appearing for Civil services, Defense services, NET/ SET and any other competitive examinations ? If yes, What is the outcome?

Yes, recently the Nodal centre of SPIPA (Sardar Patel Institute of Public Administration, Gov. of Gujarat) has been established in the university which facilitates residential coaching to selected aspirants for IBPS and SSC.

The University has established Gardi Chair through the financial support from the kind Donor, Shri Deep Chand Gardi. The chair provides guidance and coaching classes for students for such competitive exams like Bank PO, TAT (Teaching Aptitude Test), Talati, Clerk, Railways Exam, Clerical Exam, GPSC, etc. NET/SLET coaching is conducted regularly for the students.

5.1.12 Mention the policies of the University for enhancing student participation in sports and extracurricular activities through strategies / schemes such as

The University encourages the students to participate in various sports/extracurricular activities. The policies of the University for enhancing students' participation in sports and extracurricular activities are given below:

Additional academic support and academic flexibility in examinations.

The students who are participating in sports and extracurricular activities are given special attention by the faculty. The laboratory work of such students is adjusted accordingly with the next batch and internal tests, if missed due to sports and extracurricular activities are also adjusted. Under the policy of Academic Flexibility, grace marks are given as a motivational measure to all students participating at AIU recognized National/International Sports events. The students participating in sports activities are also given grace marks in final results.

Special dietary requirements, sports uniform and materials:

The University offers sports uniforms, sport kits and other materials for team members. It also provides TA/DA @ of Rs.250 per day for students and Rs. 400, per day for coach & manager during competitions/tournaments.

The Department of Sports organizes sports training/conditioning camps of various sporting events at University Sports Complex. Special diet like - high energy breakfast and quality lunch and dinner are provided during the camps.

The University provides psychological counseling for the motivation and better performance of athletes.

5.1.13 Does the university have an institutionalized mechanism for students' placement? What are the services provided to help students identify job opportunities, prepare themselves for interview, and develop entrepreneurship skills?

University has a Career counseling and a development cell under UGC scheme. The focus and objectives of cell are mentioned below:

OBJECTIVES:

1. To accumulate information on job openings available in different Institutions ,Corporate/Industry etc and to synergize the technical expertise/manpower requirement / skills etc with the academic programs/curricula /training that the University offers.
2. To analyze information in the local, regional and national contexts to explore its relevance and utility for the students in their placements and training.

3. To organize guidance workshops for informing students about the emerging professional trends and events, job profiles, add to their resumes and to impart training in soft skills.
4. To promote discipline, healthy outlook and positive attitude towards opportunities in corporate world, improving their language proficiency, preparing them for personnel interview, group discussions.

5.1.14 Give the number of student selected during campus interview by different employers (list the employers and the number of companies who visited the campus during the last four years).

Name of Employer	#Students selected
Gujarat Mineral Development Corporation, Gandhinagar	04
Banas Dairy, Palanpur	12
John Energy Ltd, Jagudan	04
India Infoline ltd.	05
Motilal Oswal securities	01
Apothechem Pharmaceuticals Pvt. Ltd	03

More exhaustive list is available with departments.

5.1.15 Does the university have a registered Alumni Association? If yes, what are its activities and contribution to the development of the university?

No, the University does not have a registered Alumni Association, however the department of Commerce and Management has its own registered Alumni Association.

Other departments of the university do have Alumni Associations which are not registered.

The Alumni Associations meet once in a year and they help current students in their placement, project work and some alumni students are also providing free services by conducting guest lecturers in the concerned department.

5.1.16 Does the university have a student grievance redressal cell? Give detail of the nature of grievances reported. How were they redressed?

Yes the university has student grievances redressal cell. University website has a link to which the students can submit their complaints. the link address is <https://docs.google.com/spreadsheet/viewform?formkey=dHN2aUVyMXZwdW01WVNnWFhmU1NJR3c6MQ#gid=0> .

5.1.17 Does the university promote a gender-sensitive environment by (i) conducting gender related programmes (ii) establishing a cell and

mechanism to deal with issues related to sexual harassment? Give details.

Yes, A Committee against Sexual Harassment, CASH has been established by HNGU, Patan since January, 2014 with order of Honorable vice chancellor to provide a healthy and congenial atmosphere to the staff and students of the University.

The Committee consists of members of the faculty, administration, Non teaching staff, a doctor and an NGO representative.

A number of awareness programs were conducted in the campus by committee members on following two issues

- To sensitize the campus community on gender issues.
- To prevent discrimination and sexual harassment against women, by promoting gender amity among students and employees.

Details of visited departments are as under.

Sr. No.	Name of Departments	Date
1	Department of Commerce & Management	27/1/2014
2	Department of Computer Science	28/1/2014
3	Department of Education	27/1/2014
4	Department of English	27/1/2014
5	Department of Law	28/1/2014
6	Department of Library & Information Science	30/1/2014
7	Department of Life-Sciences Incl. Env. Sci. & Micro.	29/1/2014
8	Department of Biotechnology	28/1/2014
9	Department of Mathematics	29/1/2014
10	Department of Physical Education	27/1/2014
11	S. K. College of Business Management	28/1/2014
12	Department of Sanskrit & Bhartiya Vidya	27/1/2014
13	Department of Social Work	28/1/2014

14	Department of Hospital Management	29/1/2014
15	Department of Physics	29/1/2014
16	Institute of Architecture	30/1/2014
17	Department of Pharmaceutical Sciences	29/1/2014
18	Department of Chemistry	30/1/2014
19	Department of M.B.A	30/1/2014

- ❖ CASH had organized a seminar on Women Empowerment on 7th March, 2014



- ❖ In this seminar, there were 410 participants (university and nearby college teachers and postgraduate students) who actively took part in this program.
- ❖ Female students from almost all departments attended this one day program and 200 students participated in different activities of this one day program.
- Non- teaching female staff members also participated in many events of the program.

5.1.18 Is there an anti-ragging committee? How many instances, if any, have been reported during the last four years and what action has been taken in these cases?

Yes, University has an anti ragging committee.

Ragging in any form is strictly prohibited and students who indulge in any such activity are dealt with severely by the authorities of the University. The Anti Ragging Committee has been established in the University as per the UGC rules and plays a vital role for the welfare of the students. The university has not received any complaint regarding ragging from its departments

5.1.19 How does the university elicit the cooperation of all its stakeholders to ensure the overall developments of its students?

The University elicits the cooperation of various stakeholders through their views/suggestions that are received during the students' industrial visits, Teacher-Parent Association meetings, Alumni meets etc. These suggestions are taken into consideration and implemented for the overall development of the students.

The academic bodies of the University also communicate their views/suggestions about the academic functioning of the University which helps in solving the problems therein.

Members of Board of Studies and Internal Quality Assurance Cell (IQAC) actively participate in the meetings and offer their vital inputs/suggestions regarding the overall development of students.

Department of Sports as well as Department of Students Welfare interact with the management, Principals, teachers and students of the affiliated colleges and ensure overall academic and extra-curricular progress of students.

The teaching faculty also interacts with the parents whenever the parents meet the teachers and the suggestions provided by the parents are taken into consideration while formulating the future mission of the university.

The University invites contribution of endowment funds from stakeholders which with which the university organizes special lectures series (to inculcate social responsibility and human values), meets expenses for the gold medals (to motivate meritorious students)etc.

Retired teachers, eminent educationists, scientists are regularly invited to deliver lectures and interact with the students closely.

5.1.20 How does the university ensure the participation of women student in intra and inter-institutional sports competitions and cultural activities? Provide details of cultural activities where such efforts were made.

The participation of women students in intra-and inter-institutional competitions and cultural activities are ensured through their involvement in various activities conducted during Youth Festival, State Level Sport Meet, All India Inter-University Tournaments etc. They are given special attention during participation. Besides these, the women students are motivated to

organize/participate in various programmes conducted at the time of welcome/Farewell functions in all Departments. The women students who are staying in the hostels actively take part in various cultural activities.

Around 25% to 40% of women students participated in inter-collegiate and inter-university sports tournaments during the last four years.

5.2 Student Progression

5.2.1 **What is the student strength of the university for the current academic years? Analyze the Programme-wise data and provide the trends for the last four years.**

Student progression	%
UG to PG*	70%
PG to M.Phil.*	5%
PG to Ph.D.	2%
Ph.D. to Post-Doctoral	0%
Employed	
• Campus Selection	10%
• Other than campus recruitment	50%

5.2.2 **What is the programme-wise completion rate during the time span stipulated by the university?**

The rate is almost 100%

5.2.3 **What is the number and percentage of students who appeared/qualified in examination like UGC-CSIR-NET, UGC-NET, SLET, ATE / CAT / GRE / TOFEL / GMAT/ Central / State Services, Defense, Civil Services, etc.?**

Details are as below:

NET	SLET	GATE	GPSC	UPSC	GPAT	TAT/TET /H-TAT
19	13	1	8	1	1	67

5.2.4 **Provide category-wise details regarding the number of Ph.D. / D.Litt. / D.Sc. these submitted / accepted / resubmitted? Rejected in last four years.**

From 2009 to 2014, 652 students have submitted their Ph.D thesis.

Year	Total
2009-10	72
2010-11	146
2011-12	177
2012-13	112
2013-14	73
2014-15	72

5.3 Student Participation and Activities

5.3.1 List the range of sports, cultural and extracurricular activities available to students. Furnish the programme calendar and provide details of students' participation.

Physical Education & Sports Activities

Year (2009-10)

University Board of Sports has been active since 1988 for students' welfare and development in the fields of sports and culture. The 21st Youth Athletic meet was organized by the Department of Physical Education.

Year (2010-11)

The 22nd Youth Athletic meet was organized by the Department of Physical Education.

Year (2011-12)

The 23rd Youth Athletic meet was organized by the S.B. Mahila Arts College, Himatnagar.

Year (2012-13)

The 24th Youth Athletic meet was organized by the Grow More College of Education, Himatnagar.

Year (2013-14)

The 25th Youth Athletic meet was organized by the Department of Physical Education, H.N.G. university, Patan.

5.3.2 Give detail of the achievements of students in co-curricular, extracurricular and cultural activities at different levels: University / State / Zonal / National / International, etc. during the last four years.

Board of student welfare is concerned with the activities, which can bring out the hidden talents in the students. The board has organized several Programmes on performing art, drama, dance, music, literature, career advancement, computer awareness etc. The youth

festival is organized every year by the board in collaboration with the affiliated colleges or the P.G. departments. The board recommends the outstanding students for participation at the zonal level youth festival.

The university's B.B.A. Department hosted the 25th and 26th Youth Festival of the University last year and current year. Above two thousand two hundred participants attended the youth festival at the university's vast campus. Selected meritorious student/ artists were nominated to participate in the 28th Inter University Youth Festival (West Zone) organized by Sivaji University, Kohlapur (Maharashtra). Given below is the list of students who won prizes in various categories:

In Elocution

Mr. Ansari Mahmud Akram A. got first prize

In spot photography

Mr. Pravin Premjibhai Chaudhary got third prize.

In Debate

Ms. Nirali Jyotindrakumar Patel, Dept. of Pharmaceutical Sciences, got Third prize.

In Collage

Ms. Unnati Pravinbhai Amin, Dept. of Pharmaceutical Sciences, got third prize.

5.3.3 Does the university conduct special drives / campaign for students to promote heritage consciousness?

Heritage walk was organized by the department of Architecture

5.3.4 How does the university involve and encourage its students to publish materials like catalogues, wall magazines, college magazine, and other material? List the major publication / material brought out by the students during the last four academic sessions.

- Publication of student magazines: University library publishes its quarterly magazine "Uttara" for students.

Apart from these, University departments like, Architecture, Life Sciences, Computer Science, etc publishes their own e newsletters, e journals for the concerned subjects.

Many departments have e study materials for students on Google Groups, which is accessed by students for their preparations.

5.3.5 Does the university have a Student Council or any other similar body? Give details on its constitution, activities and funding.

No, University does not have a student council.

5.3.6 Give details of various academic and administrative bodies that have student representatives on them. Also provide details of their activities. Senate, Extra mural studies, Board of sports, Board of cultural activity Different bodies of the university

On various academic and administrative bodies student representatives have their presence as mentioned below,

Senate-10 students,
Sports board - 02 students,
Board of student welfare – 04 students

Any other information regarding Student Support and Progression which the university would like to include.

**CRITERION VI:
GOVERNANCE, LEADERSHIP AND MANAGEMENT**

6.1 Institutional Vision and Leadership

6.1.1 State the vision and the mission of the university.

Vision of the university

- To inculcate values of equality, unity and justice
- To provide leadership in higher education by imparting quality and socially relevant knowledge
- To contribute to advancement of knowledge through research, publications and dissemination
- To make students conscious of their duty to the country and fellow human beings

Mission of the university

- To educate students in all areas of scholarship and to advance knowledge
- To develop citizens with knowledge, skill and character leading to social transformation and national development
- To develop aptitudes and skill of students to equip them to face the challenges and needs of fast emerging society
- To create greater opportunities for girl-students in order to prepare them to be effective leaders.

6.1.2 Does the mission statement define the institution's distinctive Characteristics in terms of addressing the needs of the society, The students it seeks to serve, the institution's tradition and value orientations, its vision for the future, etc.?

Yes, mission statement defines the university's distinctive characteristics in terms of addressing the needs of the society. The university's mission is to provide quality education by innovating and continuously improving upon the disciplines. it seeks to serve the students by nurturing institutions which disseminate wholesome knowledge.

The University's mission is educating students in all areas of scholarship and to advance knowledge. The social and ethical values are imparted along with technical education that promotes expertise. Students are groomed by the advanced methods of training and meaningful research.

6.1.3 How is the leadership involved in ensuring the organization's management system development, implementation and continuous improvement?

The Vice-Chancellor is the Head of the Institution. He is assisted by the Registrar, Controller of Examinations, and Deans of all different Faculties in all academic and administrative matters. The Executive Council is the supreme body of university, there are other bodies like Academic council, Senate, planning board, Board of university teaching and research (BUTR). As the chairperson of these bodies, the Vice-Chancellor ensures the smooth functioning of the university in the development of management system, implementation of policies framed and for continuous improvement.

As Chairperson of the Board of Studies and Board of Examinations, the Head of the department plays a leadership role in curriculum development and evaluation. This process ensures involvement of leadership at all levels, as per the statutory provisions of the university.

- **in interacting with its stakeholders?**

The University leadership interacts with all the stakeholders, viz. the students, parents, alumni, faculty, support staff, industry, and the community.

Interaction with the students begins from the time of admission and continues up to placement. In fact, the relationship continues even after the students leave the university through alumni associations. All the faculty and Head of the department are easily approachable by the students. All the students, faculty and non-teaching staff can meet with the Administrator every day at fixed time slots to discuss any academic matters or for grievance redressal. The management interacts with the parents during admission and whenever the parents seek an audience. The University fosters a strong interaction with the Industry by including industrialists in the Boards of Studies; university has constituted Academy-Industry linkage cell on the campus.

- **in reinforcing a culture of excellence?**

The University has conducted initiatives for promoting research culture like Research Marathon which was conducted in three phases: Phase-I, II, III Workshop under which all participants

from university departments and affiliated colleges prepared research proposals in various interdisciplinary areas and submitted the same to different funding agencies

- **in identifying organizational needs and striving to fulfill them?**

In view of the above, the faculty and the administrative authorities identify the needs of the University through various meetings and delegations. The authorities strive to fulfill the needs of the University. The short-term and long-term plans are designed and complied with the physical and financial supports.

6.1.4 Were any of the top leadership positions of the university vacant for more than a year? If so, state the reasons.

Yes, many of the top level positions are vacant for more than one year like post of Registrar, Director of Physical Education & Youth activities, University Librarian, Asst. Librarian some of the departments like Department of Hospital management and Department of Architecture are running with an incharge head of the department and till to date the above mentioned posts are not filled up because of the Govt policies.

6.1.5 Does the university ensure that all positions in its various statutory bodies are filled and meetings conducted regularly?

Yes, all positions in its various statutory bodies are filled up as and when they become vacant if it is in the purview of university administration; and meetings are conducted regularly with prior assignment of agenda.

6.1.6 Does the university promote a culture of participative management? If yes, indicate the levels of participative management.

Yes, the university promotes a culture of participative management. There are different bodies/ boards to manage different functions of university. Top most body is executive council which has representatives from different sections /strata like professors, governor nominees, state government nominees, commissioner of higher education, Principals from colleges, a Reader of university, a Dean from the university etc. EC is chaired by VC.

Other bodies are also conglomeration of various sections of

people as per the requirement of the body.

As per Section-16 university court is governed by Class-I Ex-Officio Members, University Officers, The Chancellor, The Last Vice-Chancellor, The Pro-Vice-Chancellor, The University Librarian, The Director of Higher Education, The Director of Technical Education, The Director of Health And Medical Services And Medical Education, The Chairman of Gujarat Secondary Education Board, Gujarat State, The Director of Employment And Training, Heads of University Departments, Class-II Ordinary Members, One member representative from Secondary school Teachers, Two Members from the Gujarat Legislative Assembly.

6.1.7 Give details of the academic and administrative leadership provided by the university to its affiliated colleges and the support and encouragement given to them to become autonomous.

There is a statutory provision for autonomous status, no college has applied for the same.

6.1.8 Have any provisions been incorporated / introduced in the University Act and Statutes to provide for conferment of degrees by autonomous colleges?

There is a statutory provision for autonomous status, no college has applied for the same.

6.1.9 How does the university groom leadership at various levels? Give details.

The University grooms the leadership at various levels such as Heads of the departments, Deans of Faculties, Officers of administrative departments/examination sections of the University and Principals of the affiliated colleges.

The University delegates academic and administrative powers to them and the Vice- Chancellor regularly conducts review meetings to discuss the academic, administrative and developmental matters. The University regularly organizes meetings with Principals of the affiliated colleges to guide them regarding academic plans, reforms in examination system and developmental schemes of UGC, New Delhi. As a result, an effective internal coordination monitoring system is practiced at each level.

6.1.10 Has the university evolved a knowledge management strategy? If yes, give details.

Knowledge Management Strategies of the University

Knowledge creation means

- Through research initiative acquired Minor and Major Research Projects.
- 69832 books, 110 journals, 09 news papers, 4705 e-journals, 841 CD & video, 1060 Ph.D thesis
- ICT based teaching-learning aids.
- Well furnished Computer Laboratory with Internet connectivity.
- Choice Based Credit System.
- MoUs with National/International Universities/Institutes / Industries
- Organization and participation in National/International Seminars/Conferences/ Workshops.

6.1.11 How the following values are reflected the functioning of the university? Contributing to national development: Fostering global competencies among students: University has MoUs with globally known university; there is exchange of students and faculty among many departments of the university.

Under “International Academic Relation Cell” following collaborations have taken place:

1. California State University, USA April 2011
2. West Chester University, USA January 2009
3. Penn State University, USA January 2009
4. Bhutan University 2013

- Inculcating a sound value system among students
 - Sadbhavna
 - Manav chetna Shibir
 - Personality development 22 workshops
 - Buthwariyu
 - Saptdhara
 - Vanchan sibir

- Promoting use of technology
 - Wi-Fi facility in many depts., Use of smart boards in class rooms
 - Use of projectors and smart boards in all most all departments.
 - Language lab., e-learning
 - Conducting entrance examination for M. Phil. And Ph. D degrees.
 - On line admissions, Enrolment
- Quest for excellence

The quest for excellence is reflected through the following activities:

1. The University rigorously follows the guidelines of various regulatory bodies and the syllabi of National eligibility/Entrance Tests of UGC/CSIR/ SET/ JEST/GATE and other competitive examinations, while developing and restructuring the curricula of UG and PG Programmes.
2. The UGC (Minimum Standards and Procedure for the Award of M.Phil. and Ph.D. Degree) Regulation-2009 has been adopted and implemented by the University.
3. Encouragement for research publications in reputed refereed International Journals with high impact factors.
4. Several MoUs have been signed for National/International collaborations.
5. Good research laboratories with sophisticated instruments have been developed in the departments like life sciences, Pharmaceutical science & Chemistry in their respective thrust areas/subjects.
6. Central Instrumentation Facility (CIF) & Central Instrument Maintenance Facility (CIMF) under UGC scheme are established for providing strong analytical support to active research.

6.2 Strategy Development and Deployment

6.2.1 Does the university have a perspective plan for development? If yes, what aspects are considered in the development of policies and strategies?

Yes, the university has a vision document

The vision document includes strategies and action plan for future development in terms of teaching, research, publications and extension activities.

Future Plans which are also in pipeline include:

- Plan to improve enrolment ratio in departments of university.
- Plan to Introduce Single window system for students.
- Plan to Strengthen the Alumni association and its activities
- Planning New collaborations with Industry/Universities for new courses and Training/Placement activities.
- Strengthening/Encouraging science departments for filing patents.
- Promote culture of research by acquiring more Research Project/Consultancy Projects from various funding agencies and Corporate.
- Introduction of Community Radio by university.
- Paper less administration by introduction of ERP system.
- To generate revenue from surplus land of university.
- Wi-Fi facility in whole university campus.
- Decrease student-teacher ratio in university departments.
- Making university environmental friendly by Use of Solar system for lightning, plastic free zone, Sound free zone.

6.2.2 Describe the university’s internal organizational structure and decision making processes and their effectiveness.

The university’s internal organizational structure is given below:

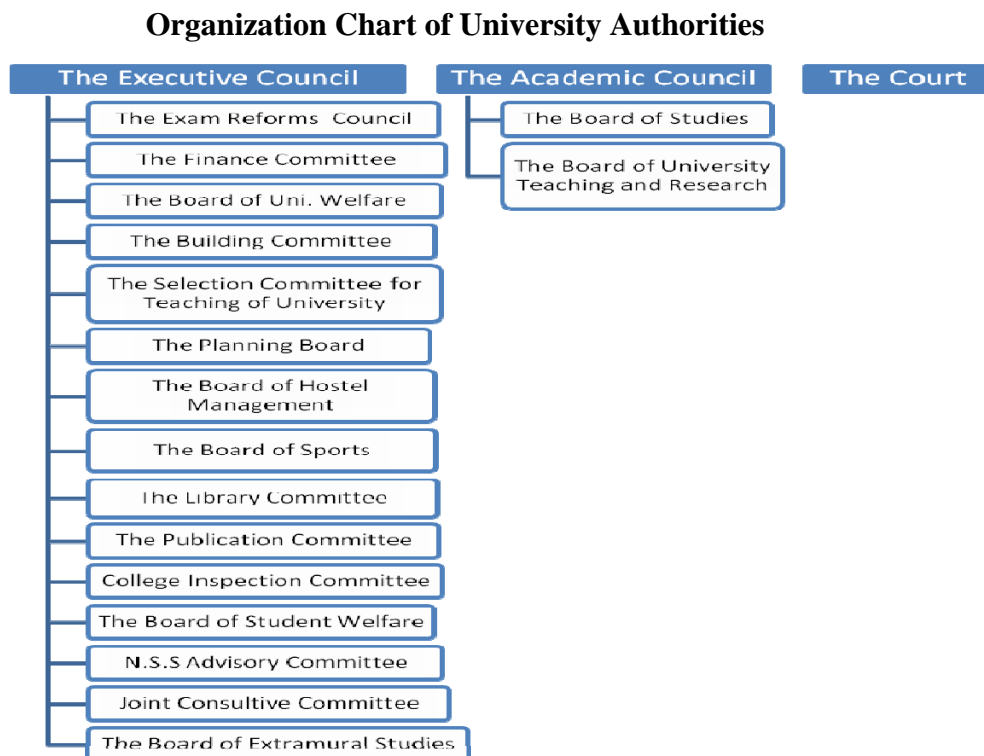

[A] Academic Wing

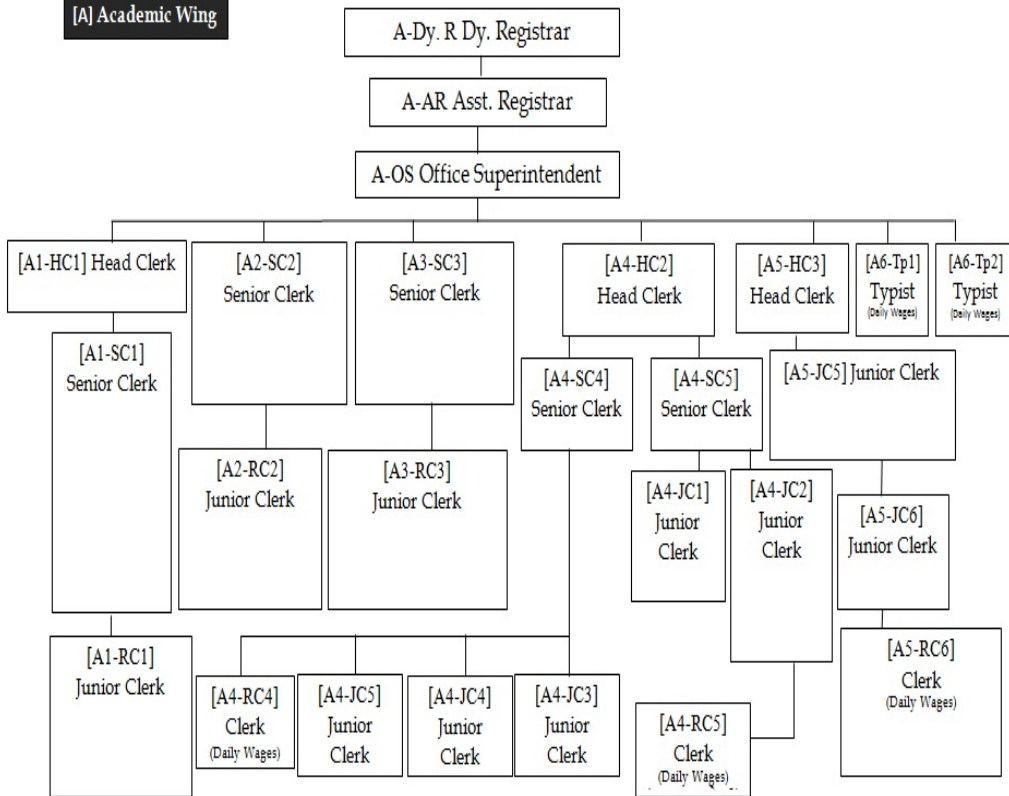

[C] Account

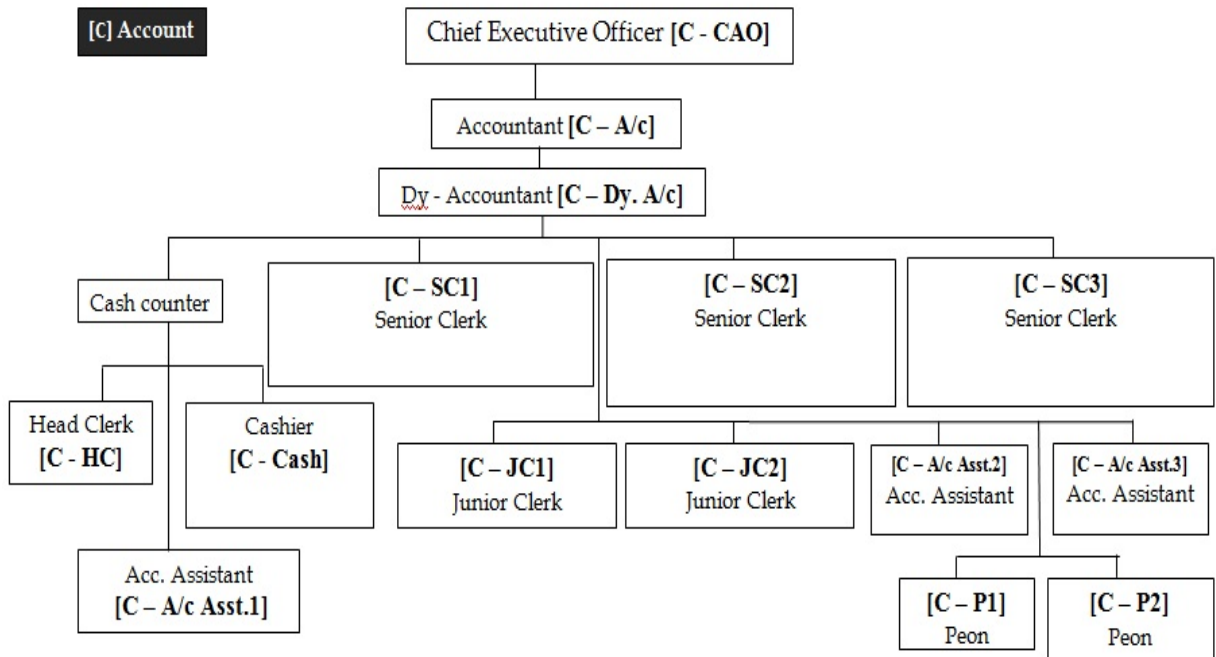

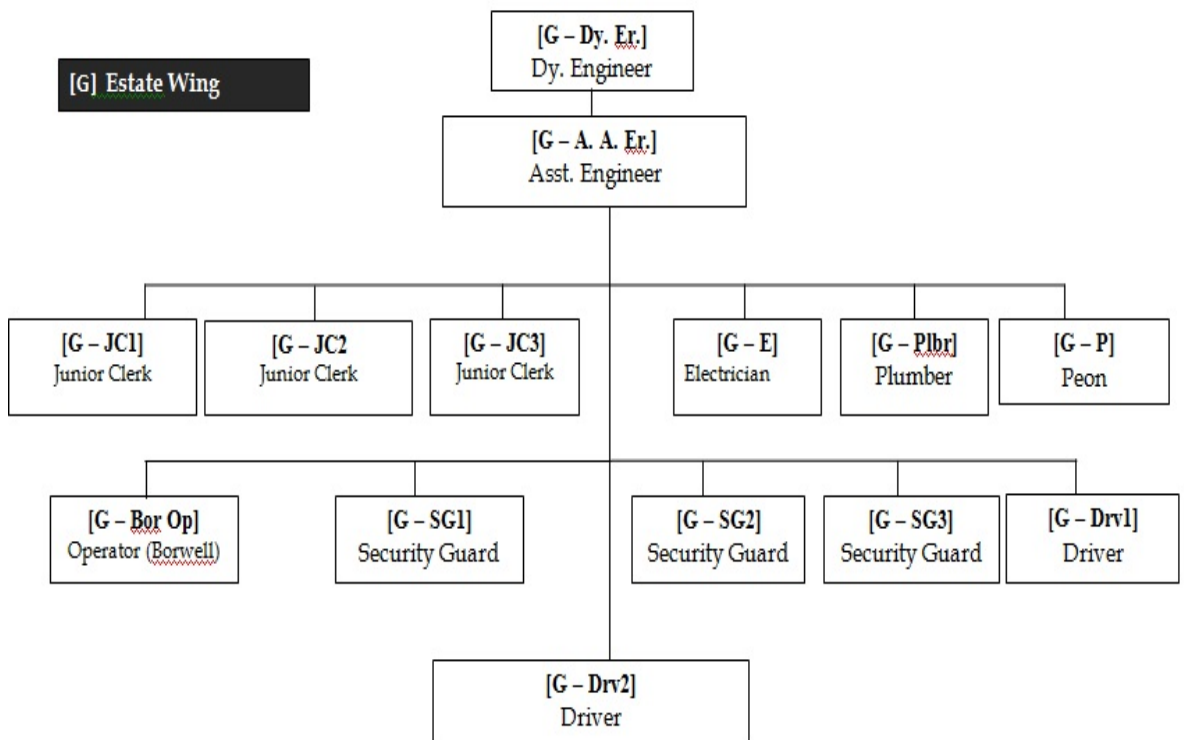
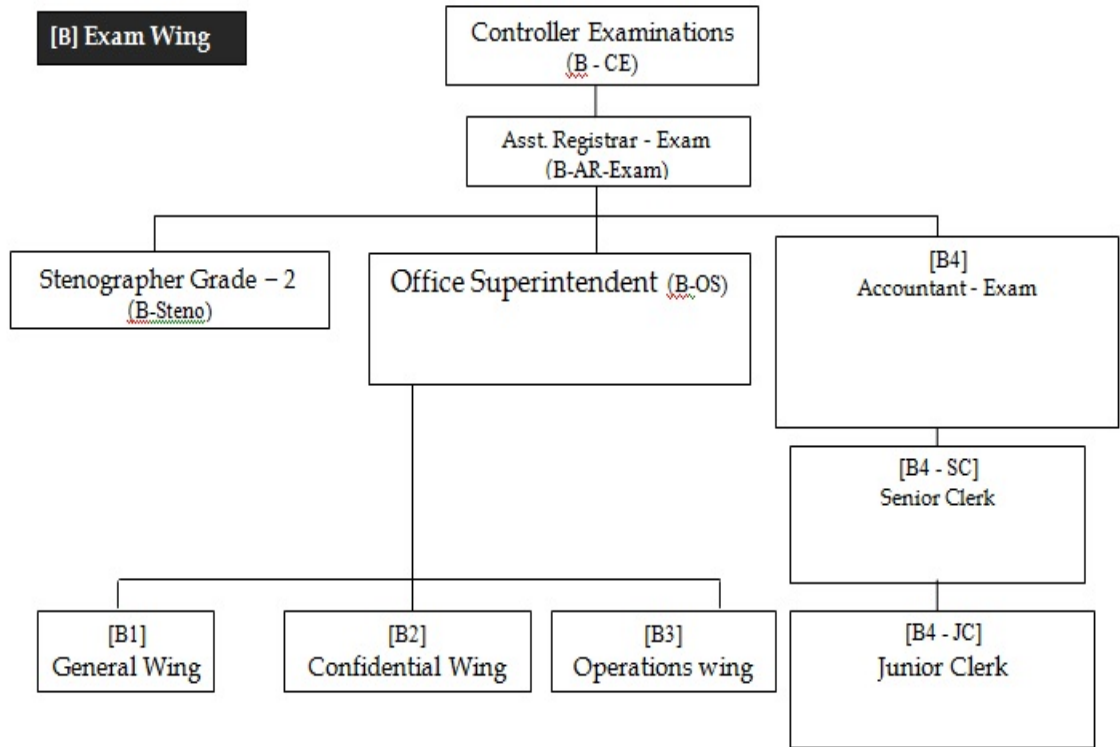

The University has four sections

- Academic section
- Accounts Section
- Examination Section
- Estate Section
- NSS
- VC Office
- Registrar Office

There are others sections UGC section, Sports section, NSS section. Each section is organised by Section in charge (SO) who is supposed to report to concerned assistant registrar. Then in the hierarchy, there is the deputy registrar, registrar, PVC. The Vice chancellor is at the top of the hierarchy and is the final signing authority.

All important/ strategic decisions are taken in the EC and VC/ PVC is the signing authority.

Routine decisions pertaining to day to day activities of the university are taken and executed by the administrative wing of the university which consists of Registrar, Deputy Registrar, Assistant registrar, Office Superintendent.

- To Ensure the effective functioning of various sections monthly/ quarterly/ half yearly table audits are conducted. During ISO certification process, a person was appointed and various teams were formed which also conducted inspection of various sections of the university.

6.2.3 Does the university have a formal policy to ensure quality? How is it designed, driven, deployed and reviewed?

Yes, the University has formally constituted a quality policy which is as follows:

Hemchandracharya North Gujarat University strives to be recognized as excellent centre of learning in higher education, technology and applied sciences. To achieve this, Hemchandracharya North Gujarat University is committed to:

Raising the quality of education and maintaining the university as effective human resource development institution under all changing conditions;

Contributing to the growth of higher education and upholding the highest ethical and professional standards;

Identifying competency needs and providing appropriate training and

professional development of staff to meet those needs;
 Conducting peer reviews of major university outputs and implementing improvements suggested;
 Maintaining dialogue with students and other stakeholders to understand their needs and expectations and determine their levels of satisfaction;
 Speedy, timely and fair disposal of the issues of students and teachers by coordinating with all departments;
 Continually improve the effectiveness of the quality management

6.2.4 Does the university encourage its academic departments to function independently and autonomously and how does it ensure accountability?

Yes, all academic departments are allowed to function independently and autonomously under the supervision of HODs/ coordinators and each department conducts a staff council meeting to decide the distribution of work of all teaching faculty. All important decisions relating to day to day activities and functioning of department are taken in the staff meetings. But all activities are decided as per the guidelines of the university.

At regular intervals the duties assigned are reviewed in the staff meetings.

Regarding financial matters, for day to day activities department heads are given sufficient autonomy as per Ordinance 22. For policy issues and big expenditures university guidelines are followed.

6.2.5 During the last four years, have there been any instances of court cases filed by and against the institute? What were the critical issues and verdicts of the courts on these issues?

Year	High Court Cases	Tribunal Cases
2010	9	4
2011	9	5
2012	1	12
2013	9	3
2014	2	1

6.2.6 How does the university ensure that grievances / complaints are promptly attended to and resolved effectively? Is there a mechanism to analyse the nature of grievances for promoting better stakeholder-relationship?

- A grievances cell has been constituted by the university which takes care of the grievances of the staff members of the university.

- Enquiries were conducted wherever required and the outcome of enquiry was communicated to the concerned faculty.
- Moreover, respective sections take due care in redressing grievances and tries to resolve the same as quickly as possible. Monitoring of grievances is done by Head/ Sectional head.
- Student grievances mechanism: Each department has a complaint box and a complaint register where student can register their grievances. The complaints that are received are resolved by respective Heads of the departments.

6.2.7 Does the university have a mechanism for analyzing student feedback on institutional performance? If yes, what was the institutional response?

Yes, combined feedbacks are taken from students and the analysed outcome is sent to respective departments. The outcome is distributed to all faculties in staff meetings. It is ensured in staff meetings that all issues raised by the students shall be incorporated in the future planning of the university.

6.2.8 Does the university conduct performance audit of the various departments?

YES, the university follows the ISO 9001: 2008 certification to conduct the performance auditing of its departments. According to the requirement of standards Quality Policy, Quality Management System was created by ISO cell. On May 9, 2012 first Internal Audit was done and final audit was done on May 15, 2012. Based on final audit University has been awarded ISO 9001: 2008 certificate on July 23, 2012. Citizen charter was released on September 28, 2012.

Office manual revision workshop was arranged by ISO cell during April 12-13, 2012.

The various bodies of the university namely Board of Studies, Academic Council and Executive Council and Finance Committee are reviewing process of university time to time.

The University achieved 48th rank in all India ranking.

	47	-	Jaipur National University, Jaipur
	48	-	Hemchandracharya North Gujarat University, Patan
	49	50	Mahatma Gandhi Kashi Vidyapeeth, Varanasi
	50	-	Maharaja Krishnakumarsinhji Bhavnagar University, Bhavnagar

The overall rank is based on the overall score comprising perceptual and factual scores, not on perceptual and factual ranks.  New entrant.

IQAC conducts internal audit regularly for university departments.

6.2.9 What mechanisms have been evolved by the university to identify the developmental needs of its affiliated institutions?

Creation of the University - College resource planning (URP) system jointly created with financial support from college and university. This included Computerization and atomization of processes, starting from the Admission, Enrolment, Examination, Electoral and other information management between College and University. Dynamic portal was created for collection of the input from the various faculties regarding their academic progress. ISO cell also initiated online registry in Inward section free of cost with collaboration of NIC India.

As and when applications of affiliated institutions are received by the University, the same is sent to various bodies/ boards of university keeping in mind the priority and the importance to be given to the needs and demands. The final signing authority is VC on the behalf of EC.

Most of boards/ Bodies of university have representatives of affiliated institutions/ colleges so that their needs get represented in the university. The university also conducts the surprise visit of colleges is also organized.

6.2.10 Does the university have a vibrant College Development Council (CDC) / Board of College and University Development (BCUD)? If yes, detail its structure, functions and achievements.

Yes, the university has a vibrant College Development Council (CDC) / Board of College and University Development (BCUD) as per the university Statute – 196

The college development committee Ensures the proper planning and integrated development of affiliated colleges and provides the colleges necessary help and guidance in their development. It serves as a link between the University; the University Grants Commission, the State Education Department and the affiliated colleges.

The College Development Committee consists of the following Members;

- (a) Vice-Chancellor (Ex-Officio) Chairman
- (b) The registrar (Ex-Officio) Secretary
- (c) One Dean from the Deans of the Faculties of arts, Science, Commerce by rotation to be nominated by the Vice-Chancellor.
- (d) One member of the Executive Council from amongst the members themselves, nominated by the Executive Council.
- (e) One member of the Academic Council to be nominated by the Executive Council.

- (f) One principal of an affiliated College to be nominated by the Executive Council from the Court.
- (g) One teacher from the University Department to be nominated by the Executive Council from the Court.
- (h) One representative of the Management of affiliated Colleges to be nominated by the Executive Council from the Court.
- (i) One teacher of the affiliated Colleges to be nominated by the Executive Council from the Court.
- (j) One representative of students to be nominated by the Executive Council from the University Court.
- (k) Such other members as may be nominated by the Vice-Chancellor subject to the condition that the total number of the member of the committee shall not exceed 15.

The terms of the office of the members other than Ex-Officio members of the Committee shall be three years. Provided that a member who is nominated on the Committee shall cease to be a member of the Committee if and when he ceases to hold the office by virtue of which he was nominated. In view of casual vacancy, the vacancy shall be filled in by nomination by the Vice-Chancellor for the unexpired portion of the term.

(3) The College Development Committee shall meet at regular intervals at least twice in an academic year, on a date to be fixed by the Vice-Chancellor.

(4) Following shall be the functions of the College Development Committee.

- (a) The College Development Committee shall be deliberative body.
- (b) It will make suggestions to the University on issues pertaining to the development of affiliated Colleges.
- (c) It will suggest strategies to benefit from various schemes of assistance of the University Grants Commission meant for affiliated Colleges.
- (d) It will suggest measures for improvement of standards of instruction and examination in affiliated colleges.

(5) The Vice-Chancellor, and in his absence a member elected by the Committee shall preside over the meetings of the Committee.

6.3 Faculty Empowerment Strategies

6.3.1 What efforts have been made to enhance the professional development of teaching and non-teaching staff?

Professional development of teaching staff is enhanced by organising/ attending seminars, conferences, workshop , Refresher and orientation courses. As per university policy all teaching faculty is

allowed to attend any of such activity two times a year. All faculty members are encouraged to present their research proposals and the university provides necessary support to them.

For non teaching staff members two workshops were organised on RTI Act, many staff members were sent for computer trainings. Workshops were also conducted for record keeping in coordination with SPIPA. ISO training was also conducted for both teaching and nonteaching faculty members.

6.3.2 What is the outcome of the review of various appraisal methods used by the university? List the important decisions.

The university has a self-appraisal system to evaluate the performance of its faculty as per Government norms. Each faculty member is required to submit a self-appraisal report annually on the basis of the parameters like - teaching hours, subjects taught, research papers/articles/books published, conferences attended, papers presented in the conferences, new curricula designed/developed, participation in extracurricular /cocurricular activities, extra responsibilities assigned by the university, and other contributions made towards the society. The self-appraisal reports of the teaching staff, duly verified by the Directors/ Heads of respective Schools/Institute are evaluated by the Hon'ble Vice-Chancellor.

As per Sixth Pay Commission, for all the appointments of Teachers/Librarian/ Directors of Physical Education and Career Advancement Promotions, the Academic Performance Indicators (API) are made mandatory.

6.3.3 What are the welfare schemes available for teaching and non-teaching staff? What percentage of staff have benefitted from these schemes in the last four years? Give details.

The following welfare schemes are available for the teaching and non-teaching staffs of the University:

The Karamchari Kalyan Trust is managed by university non teaching staff, which provides various facilitations to employees like - Teaching and nonteaching Rs 25000/ are given for any treatment (Related to health).

Vehicle loans are easily made available to all staff members at a low interest rates.

Provides loan for the purchase of computer/laptop at 0 % interest.

Provides medical treatment/facilities at concessional rates through the Health Center of the University.

Provides festival advance to Class-III and Class-IV employees every year.

Zero tuition fees for the wards of the employees for getting

admission in the Self financed course of University Schools/Institute.

Pension Scheme and Defined Pension Scheme for employees in the service of the University before and after 2005, respectively.

Leave Travel Concession (LTC) benefit is available to the employees of the University.

Sports complex and its resources like gymnasium are available to all employees.

Travel and accommodation allowance for attending workshops/seminars knowledge enhancement is available to employees.

The facility of **Day Care Centre** is available for the wards of female employees of the University.

The Maternity Leave of 180 days is given to the female employees and 15 days paternity leave to male employee.

Adequate accommodation (Quarter) facilities on the campus are provided for both teaching and non-teaching staff.

6.3.4 What are the measures taken by the University for attracting and retaining eminent faculty?

- Provisions for EL which is entailed to some of our faculties
Yes, there is provision for EL

For Self finance program there is provision of Gratuity and Provident fund

The following provisions are there for attracting and retaining eminent faculty:

- provides TA/DA and Reg. Fee to attend con/Workshop from uni fund./UGC
- In many depts. They are provided to and fro free convene to carryout various activities in the various dept.
- They are offered remuneration as per UGC guidelines or many times more than that.
- Their convenience taken into consideration even holidays are considered as working days for them.
- Free accommodation to guest faculty and many other facilities.

6.3.5 Has the university conducted a gender audit during the last four years? If yes, mention a few salient findings.

University has Committee against Sexual Harassment, Equal opportunity cell which takes care about relevant issues.

Gender data is collected every year by statistical cell and it is mentioned in yearly report of university.

6.3.6 Does the university conduct any gender sensitization programmes for its faculty?

- Committee against Sexual Harassment is functioning in the University and conducts relevant programmes regularly.
- MSW deptt. is also active and organizes such activities for students also.
- Female faculties are associated with WILPF.
- Seminars on women empowerment/Awareness on Domestic violence act were conducted.

6.3.7 What is the impact of the University's Academic Staff College Programmes in enhancing the competencies of the university faculty?

At present the university does not have an Academic Staff College. A Proposal has been sent to the UGC for the same.

6.4 Financial Management and Resource Mobilization

6.4.1 What is the institutional mechanism available to monitor the effective and efficient use of financial resources?

University has Accounts section in the administrative wing of the university.

- Finance Committee, Planning board, Executive Council, Senate approves the allocation of funds as decided by State Government and UGC.

Execution of purchase and distribution is done by estate, Store dept.; Finance committee takes a final decision in this matter. Purchase related to computer and accessories, Chemical & Glassware related tendering is done through departments and account section makes the payment.

HNGU is the only university in Gujarat adopted double entry system

The Local Fund Audit department is an independent audit department under the administrative control of Finance Department of the State Government which audits yearly the accounts of the university.

UGC – Projects and fund allocated as per guidelines of UGC are transferred to relevant departments/Pis.

Monitoring is done by carrying out internal audits twice a year and Audit by CA is done annually.

6.4.2 Does the university have a mechanism for internal and external audit? Give details.

Yes, as mentioned in 6.4.1, the university conducts internal as well as external audit.

Creation of online Inventory register/Dead stock is in progress.

6.4.3 Are the institution's accounts audited regularly? Have there been any major audit objections, if so, how were they addressed?

Yes. The accounts have been audited regularly as per the intimation and audit programme set by the external audit authority.

Audit Details

Local fund audit: audit has been completed up to the year 2010/11.

The audit for the period 2011/12 will commence from Jan-2015 as per the instructions received from Local Fund Office.

6.4.4 Provide the audited income and expenditure statement of academic and administrative activities of the last four years.

**INCOME AND EXPENDITURE ACCOUNT FOR THE YEAR
ENDED ON 31ST MARCH 2010**

EXPENDITURE	SCH.	AMOUNT	INCOME	SCH.	AMOUNT
	NO.	IN RS.		NO.	IN RS.
GRANTABLE EXPENSES	15	70992825	GRANTABLE INCOME	20	112102177.6
ADMINISTRATIVE EXPENSE	16	127949558.9	EXAMINATION INCOME	21	53810311
EXAMINATION EXPENSE	17	26120160	SELF FIN INCOME	22	43369759
SELF FINANCE EXPENSES	18	20768019	NON GRANTABLE INCOME	23	39106838.3
NON GRANTABLE EXPENSES	19	2558523			
		248389085.9			248389085.9

**INCOME AND EXPENDITURE ACCOUNT FOR THE YEAR
ENDED ON 31ST MARCH 2011**

Expenditures	Sch. No.	Amount	Incomes	Sch. No.	Amount
Expenses of Grantable Dept.	16	151604452	Income of Grantable Dept.	21	112790818.1
Administrative Expenses	17	24882667.03	Examination Incomes	22	62253797
Examination Expenses	18	29721231	Income of Self finance Dept.	23	47378759
Expenses of Self Finance Dept.	19	34618119	Other Income	24	48063068.37
Other Expenses	20	29659973.46			
Total		270486442.5	Total		270486442.5

**INCOME AND EXPENDITURE ACCOUNT FOR THE YEAR
ENDED ON 31ST MARCH 2012**

Particulars	Sch. No.	Amount
Expenditure:		
Expenses of Grantable Dept.	16	174885587
Administrative Expenses	17	26730795.21
Examination Expenses	18	41013083
Expenses of Self Finance Dept.	19	42934672
Other Expenses	20	40868278.23
Total		326432415.4
Income:		
Income of Grantable Dept.	21	100267014.9
Examination Income	22	80134946
Income of Self Finance Dept.	23	54796135
Other Income	24	91234319.57
Total		326432415.4

**INCOME AND EXPENDITURE ACCOUNT FOR THE YEAR
ENDED ON 31ST MARCH 2013**

Particulars	Sch. No.	Amount
Expenditure:		
Expenses of Grantable Dept.	16	173435507
Administrative Expenses	17	32514171.03
Examination Expenses	18	39118258.85
Expenses of Self Finance Dept.	19	46329717
Other Expenses	20	102705825.1

Total		394103479
Income:		
Income of Grantable Dept.	21	94619831
Examination Income	22	112142210
Income of Self Finance Dept.	23	67163508
Other Income	24	120177930
Total		394103479

6.4.5 Narrate the efforts taken by the University for Resource Mobilization.

The faculties of departments are encouraged through our research initiative programs to mobilize resources for research activities and strengthening the departmental facilities by applying to various funding agencies such as DST, UGC, GUJCOST, CSIR, ICAR-ICMR, ICSSR, etc..

- The outcome of this initiative is that the university has received more than 2.5 crore rupees as research grants in last few years.
- The University has also generated resources especially in terms of donations received from philanthropists and charitable trusts. More than 2 crore rupees have been received from various sources as donation.
- The University has a corpus fund of more than Rs.2.8 crore.
- The University has received Rs. 50 lakhs under WORLD CLASS UNIVERSITY scheme from the Government of Gujarat.
- The University has generated a sports complex development fund of more than 2.3 crore.
- The University has generated a Library development fund of more than 6 lakhs.
- The self-finance department/courses sfunctioning on the University campus deposits 25% of their revenue to the University Reserve Fund.

6.4.6 Is there any provision for the university to create a corpus fund? If yes, give details.

Corpus Fund	Amount
Aanart Donation	25001.00
Computer Tech. Edu.	1500000.00
Donation For Championship Trophy A/c	141000.00
Donation For I.H.Sheth Schollership (Maths)	60111.00
Donation - V.D. Gardi Chair Donation A/c	10000000.00
Goldmedal Donation	1810758.00

Guruvandana Sanskruti Vyakhyanmala	111111.00
Hem. Sahitya Research Donation	501000.00
M.I.Prajapati Sanskrit Vyankhy	30000.00
Donation For Prize For Sanskrit Student	600000.00
Siddhhem Prakasan Donation	750000.00
Sports Activities Donation	86000.00
Umashankar Joshi Vyankhyanmala	25000.00
Mohanlal Patel Vyakhanmala Donetion	500000.00
Matching Grant(U.G.C.)	12438694.00
University Corpus Fund	81000.00
Total	28659675.00

6.5 Internal Quality Assurance System

6.5.1 Does the university conduct an academic audit of its departments? If yes, give details.

The Academic audit of all the departments has been initiated by IQAC with an exhaustive audit tool served to each department. All departments conduct the academic audit as advised by the IQAC in their individual capacity. Such academic audit report is submitted to the IQAC by the end of the academic year.

6.5.2 Based on the recommendations of the academic audit, what specific measures have been taken by the university to improve teaching, learning and evaluation?

Following are the few initiatives taken for the overall improvement.

Teaching:

- The curriculum is revised and updated looking to global trends and local needs.
- Our University was the first among all the state universities to introduce CBCS.
- Departments on the campus are equipped with the excellent infrastructure and the latest teaching aids.
- Dipchandbhai Gardi chair prepares students for various competitive exams and arms students with a competitive edge.

Learning:

- The University has taken several measures to improve the academic atmosphere of the University and many administrative and academic steps and programmes are initiated.
- SPIPA training centre will help university staff in various training activities.
- The students are encouraged for further training, research and skill development at the University and at other places.
- The administrative staffs are also updated with computer skills (recent training with Microsoft) which help them serve better.

Evaluation:

- The evaluation system includes both internal and external exams for each paper/ course/program.
- The internal marks of the students are further divided into various modes like tests, assignments, oral viva, etc.
- Remedial classes are also arranged for slow learners.

6.5.3 Is there a central body within the university to continuously review the teaching learning process? Give details of its structure, methodologies of operations and outcome?

The Board of University Teaching and Research

The Board of University Teaching and Research is responsible for maintenance of standards of Post-Graduate teaching and research and also makes recommendations regarding the admission to and evaluation of research degrees. (Statute -177)

The Academic Council

The Academic Council is the Academic body of the University which is responsible for the maintenance and standards of teaching and examination of the university.

The meeting of the Academic Council was held on below mentioned dates during the reporting year.

1.) 21/04/2012 2.) 02/07/2012 3.) 31/08/2012 4.) 25/03/2013

(Section -21 – Four times in a year)

The Board of Studies

The Board of Studies recommends courses of studies in the subject in which the board is concerned and prescribes necessary books for study in the subject.

The College Development Committee

The College Development Committee ensures the proper planning and integrated development of affiliated colleges and provides the colleges necessary help and guidance in their development. It serves as a link between the University, the University Grant Commission, the State Education Department and the Affiliated Colleges. (Statute -196)

6.5.4 How has IQAC contributed to institutionalizing quality assurance strategies and processes?

The IQAC has helped institutionalize and streamline the process of quality assurance regarding the functioning of all aspects of the institution. The IQAC has a formal structure and holds regular meetings and communicates its findings to the different departments and administrative sections along with suggestions for improvement.

6.5.5 How many decisions of the IQAC have been placed before the statutory authorities of the university for implementation?

The IQAC had made several suggestions and placed them before statutory authorities of the University for Implementation. Some of them are mentioned below:

- To Introduce the CBCS.
- To constitute a Grievance Redressal Cell for the following :
 - Students
 - Non-teaching employees
 - Teachers
- To promote interdisciplinary teaching-learning and research and cross integration of various courses.
- Development of suitable feedback mechanism by all stakeholders of the University
- To review current practices in different teaching and administrative departments of the University and suggest necessary reforms/modification to enhance quality.
- To make necessary improvements in the existing infrastructure that may facilitate quality enhancement and service deliveries by the University.
- Phased introduction of e-governance (file tracking system, digitalization of records, single window system) for timely, transparent and quality delivery of various services to students, employees and employers.
- Promotion of linkage between academia and industry.
- Adoption of zero tolerance policy towards plagiarism.

6.5.6 Does the IQAC have external members on its committees? If so, mention any significant contribution made by such members.

YES, IQAC committee consists of internal members from university itself and external member as special invitee.

6.5.7 Has the IQAC conducted any study on the incremental academic growth of students from disadvantaged sections of society?

So far no study has been conducted on incremental academic growth of students from disadvantaged section of society, but due care

is being taken to facilitate such students, there are different cells which are working for disadvantaged students like SC/ST cell, Equal opportunity cell, career counseling cell, CASH, etc.

6.5.8 What policies are in place for the periodic review of administrative and academic departments, subject areas, research centres, etc.?

The Planning Board (Statute – 75)

The periodic review of administrative and academic departments is done by the planning board. The functions of the Planning Board are mentioned below:

The Planning Board shall advice and prepares long-term plans of the University to generate new ideas and programmes and to help the University in Periodical evaluation of its work. Motivate Board of Studies in all subjects to review and modify different syllabi in the Departments and affiliated colleges.

CRITERION VII INNOVATIONS AND BEST PRACTICES

Introduction

At every stage in its 25 years of history, the Hemchandracharya North Gujarat University has followed innovative and healthy practices for all its stakeholders and Higher Education at large. Higher educational institutions are expected to build optimally healthy practices in following areas:

1. Motivating students for diverse talent and ways of learning.
2. Encouraging increased interaction between students and faculty.
3. Developing cooperation among students.
4. Active learning through advanced teaching tools.
5. Total quality management in university education system.
6. Delegation of authority to staff and continuous feedback and monitoring system.

The essence of innovation consists in improving the human knowledge so that it can serve the society in a better way. The university follows the best practices and innovations in the field of learning process, human development and research.

7.1 Environment consciousness

7.1.1 Does University Conduct green audit for its campus:

The university has eco-friendly campus which addresses the issues of carbon neutrality, waste management and focuses on the plantations inside the campus. The university also encourages the students to reduce pollution inside the campus. All laboratories of science and technology departments are advised to follow the university recommended standard and safety measures. The department of industrial safety conducts regular audit of all departments and sections inside the university campus and advises them to follow strict safety measures.

7.1.2 What are the initiatives taken by the university to make campus eco-friendly:

Energy Conservations: The University is conscious about energy conservation on the campus. The following steps have been taken by the university to reduce energy consumption which in the long run helps to conserve energy:

- All electricity fittings are done with energy efficient tools like MCB and ELCB.
- Plans are underway to use solar energy power on the campuses to reduce power consumption and use alternative sources of generating power which would help in overcoming the power crisis.

- Air-conditioners are installed where there is utmost need and the air-conditioning units are branded and energy efficient.
- All buildings in the university campus have adequate ventilation and sunlight. It reduces the energy consumption during day-time.

Water Harvesting: Rain water harvesting is planned for all the new/proposed constructions in the University.

Drinking water safety: The ground water in the city has a very high level of fluoride. Therefore, the university has installed RO plants in all buildings including hostel buildings of the university campus. All water tanks are cleaned at a stipulated time. The RO and water purification system is serviced regularly.

Efforts for carbon neutrality: The University has planted Neem and other trees which support carbon neutrality. The campus has been declared as ‘NO SMOKING’ zone. The university encourages reuse of waste paper for regular administrative use. All waste papers, specially used answer books are sent for pulping by tender mechanism. The burning of laboratory waste and other waste materials is done with due care.

Hazardous waste Management: The disposable bio-waste and hazardous waste materials of laboratories are disposed as per the standards and laws set by the Government.

Plantations: The University conducts various awareness programmes for tree plantations for the students and society as a whole. The estate department of the university is given the overall responsibility to manage tree plantations inside the university campus.

Use of renewable energy: Plans are underway to use solar energy on the campuses to reduce power consumption and use alternative sources of generating power which would help in overcoming the power crisis. University has plans to install solar lights.

Safety Audit: The Department of Industrial safety conducts regular safety audit in all departments of the university. It also prepares reports and suggests precautionary measures to be adopted by concerned departments for the safety of students.

7.2 Innovations:

The universities are meant for research. The university requires innovations in Education, Research and Governance. The innovative

practices by the Hemchandracharya North Gujarat University in all three areas are given below:

7.2.1 Innovations in Education:

To nurture the innovation in education, this university has initiated the following steps:

- * Case based learning method in professional courses.
- * Developing students' creative thinking and problem solving capacity
- * Introducing innovative courses like health care management, environment safety and vocational course like fashion designing to address the problem of employability of the students and expectations of the employers.
- * To encourage and promote the faculty members to avail of various fellowships.
- * Making use of technology in classroom teaching.

The university also follows innovative approaches by introducing Innovative programmes looking to the societal needs like:

- o Programmes related to healthcare management: Master of Hospital Management and Executive programme for In-service doctors.
- o Five year integrated programmes like; M. Sc. (CA& IT) and MCA.
- o Programme for environment safety like; Post-Graduate Diploma in Industrial Safety.
- o The university has started Vocational courses on university campus with the financial support from University Grant Commission (UGC) from the academic year: 2014-15.
- o Plans are under way to start a Setelite campus of the university for tribal students. Recently, the university has acquired 100 acres of land from the state government at Vadali- Khedbhramma, District- Sabarkantha.

7.2.2 Innovations in Research:

Encouraging Faculty for research Work: Research workshops are organized regularly to encourage the faculty members for research. They are also taught to prepare research proposals, which is mentioned in criteria no: III.

Dissemination of research findings: Lab to Land programme has been initiated to ensure that all innovations achieved in all the laboratories of the Hemchandracharya North Gujarat University are shared with people at the grass root

level. Within this framework, the healthy practices introduced in the Hemchandracharya North Gujarat University can be classified as innovations which foster Institutional Health, healthy practices for Teachers as academic, service related, motivational and quality upgrading efforts, Healthy practices for Students as academic, infrastructural, financial and health support oriented efforts, Healthy practices for Administrative, Technical and Other Non-Teaching Staff Members.

7.2.3 Innovations in Governance:

The governance structure is based on delegations of powers and authority. The university follows good governance practices for the betterment of students as well as for the society. The university has a consistent record of declaring results of the examinations on time. The university has prepared citizen charter for the students wherein the time duration is specified for each kind of activity. The university also provides helpline facility for students. The single window system has been introduced by the university, so that students are provided quick and efficient service.

7.3 Best Practices:

7.3.1 Vision & Mission statement:

The university has a well defined vision and mission statement. This is displayed at all prominent places of university. The university is striving to work as per the vision and mission statements.

7.3.2 Citizen charter:

The University has prepared citizen charter for the students, which helps the students to know the duration of all types of activities. The time limit is specified for almost all administrative activities of the university. The citizen charter helps the students in getting a better service from the university administration..

7.3.3. Online admission and enrollment process:

The university has introduced online central admission procedure for courses run by the departments of university. The student enrollments procedure is also made online for university departments as well as for affiliated colleges of the university.

7.3.4 Career Guidance and Counseling

Smt. Vidyaben Deepchandbhai Gardi Chair was established through the financial support of Deepchandbhai Gardi in Hem. North Gujarat University Campus to stimulate the competitive approach in students. The aim of this chair is to Circulate information about career opportunities to interested students, Organizing seminars and presentations on personality development programs, Improving communication skills of students, Creating awareness about the opportunities to pursue higher studies in India and abroad, Conducting mock interviews on the campus, Develop competitive potential in graduate students of HNGU for exams like GATE, GCET, JNU, CAT, Develop competitive potential in Post graduate students of HNGU for exam like UGC NET, SET, Develop competitive potential in students of HNGU for job oriented exams like UPSC, GPSC, Bank recruitment , Railway recruitment and Entrepreneurship development

7.3.5 Manav Chetna Udhvarohan Samaroh:

Every year university organizes “Manav Chetna Udhvarohan Saptah”. Eminent Speakers are invited to deliver lectures on important Social and Religious issues where, University staff and peoples from Society are invited as audience .

“**Manav Chetana Urdvarohan Saptah**” organized every year by the University Library.

Sr. No.	Date / Year	Hon. Speaker	Subject
1.	Date : 23 November, 2009 to 29 November, 2009		
	23 November, 2009	Shri Sudarshan Aayangar	Gram Swaraj – Aja ni Anivaryata
	24 November, 2009	Sushri Jyotibahen Thanki	Shri Arvind nun Utkanti man Pradan
	25 November, 2009	"	Manthi Atimanas
	26 November, 2009	"	Dainik Jivan man Yogsadhana.
	27 November, 2009	Sushri Mirabahen Bhatt	Vinoba nun Niralun Vyaktitva.
	28 November, 2009	"	Ahinsa – Ajano

			Yugdharma.
	29 November, 2009	"	Stri – Purush nun Sah – Nagarikatva.
2.	Date : 11 September, 2010 to 17 September, 2010		
	11 September, 2010 to 17 September, 2010	Dr. Shri Ashvinbhai Kapadiya	Shrimad Bhagavat Gnanyagnan.
3.	Date : 17 September, 2011 to 22 September, 2011		
	17 September, 2011	Dr. Amrapali Marchat	Vartaman man Gandhi
	18 September, 2011	Dr. Prafulbhai Patel	Sanskritik Katokati man Manaviya Mulyo ni Sthapna.
	19 September, 2011	Dr. Manibhai H. Patel	Manav Chetana ane Sahitya
	20 September, 2011	Dr. Purushottambhai G. Patel	Vipashyana Adhyatma Jivan ni Shaili.
	21 September, 2011	Mahebbubhai Desai	Suki Santo ni Parampara man Islamano Sandesh.
	22 September, 2011	"	Islamno Sandesh Nava Sandarbhe.
4.	Date : 11 September, 2012 to 16 September, 2012		
	11 September, 2012	Shri Rohitbhai Shukla	Geeta-Upanishad-Vinoba
	12 September, 2012	"	"
	13 September, 2012	"	"
	14 September, 2012	Shri Pravinbhai K. Laheri	Samprat samaya man Sarvoday ni Bhumika
	15 September, 2012	Shri Vidhutbhai Joshi	Gandhi – Ajana Sandarbha man
	16 September, 2012	Shri Bhadrayu Vachchharajani	Gandhi-Vinoba Shikshan Vichar Aje Kyan Che ?
5.	Date : 11 September, 2013 to 16 September, 2013		
	11 September, 2013	Shri Gopalkrushna Bharad	Gandhi-Vinoba ane Amaro Prayas
	12 September, 2013	Shri Rajubhai Purohit	"
	13 September, 2013	Shri Anand Mazagavakar	"
	14 September, 2013	Shri Rajanibhai dave	"
	15 September, 2013	Shri Sanjaybhai Bhavasara	"
	16 September, 2013	Shri Mahendrabhai Bhatt	"
6.	Date : 8 September, 2014 to 12 September, 2014		

	8 September, 2014	Pujya Swami Nikhileshwaranaji	Sakaratomak Vichar ane Swami Vivekanand
	9 September, 2014	Shri Manibhai Patel	Sardar Katha
	10 September, 2014	"	"
	11 September, 2014	"	"
	12 September, 2014	Shri Narendra Trivedi	Swami Vivekanand ni Drashtie Vishvabandhutva.

University also organizes lecture series named “Shree Mohanlal Patel Bhartiya Sahitya Vyakhyanamala”

Shri Mohanlal Patel "Amrut Parv" Committee had donated 5,00,000 lacks on 28-12-2001 for the Shree Mohanlal Patel Bhartiya Sahitya Vyakhyanamala. University Library organized Lecturer Series From the interest received from donation amount "**Amrut Parv**".

Sr. No.	Date / Year	Hon. Speaker	Subject
1	17 March, 2009	Shri Raghuvir Chaudhari	Gujarati Aitihāsik Navalkatha man Patan
2	5 March, 2010	Dr. Chandrakant Sheth	Madhyakalin Sanskrutik Parivesh ane Kavi Premanand ni Sarjakta.
3.	15 March, 2011	Padmashri Bholabhai Patel	Ravindranath Tagor ni Kathasrushti.
4.	11 January, 2012	Pro. Indranath Chaudhari	Mahatma Gandhi Aur Ravindranath Tagor.
5.	28 February, 2013	Pro. Dr. Balavant Jani	Bharatiya Bhakti Parampara ni Anokhi Mudra : Nasihat ane Ginan Swarup ni Rachanao.
6.	12 February, 2014	Dr. Mahavirsinh Chauhan	Bharatiya Navjagaran Aur Narmad
7.	17 December, 2014	Pro. Dr. Vishvanatha Prasad Tiwari	Sahitya Aur Rachanaki Prakruti

Late Umashankar Joshi lecturer series is also organized every year by the University Library.

Sr. No.	Date / Year	Hon. Speaker	Subject
1	10 February, 2009	Shri Narottam Palan	Umashankar Joshi nun Purano man Sanshodhan.
2.	5 March, 20110	Dr. Ravindra Dave	Umashankar Joshi : Gujarati Shikshan na Preranastrot.
3.	15 March, 2011	Shri Mansukh Salla	Umashankar Joshi Shikshankar
4.	23 March, 2012	Padmashri Bholabhai Patel Shri Raghuvir Chaudhari Dr. Balavant Jani Pro. Chandrakant Sheth Dr. Manilal H. Patel Dr. Kishorsinh Solanki	Umashankar Joshi - Pannalal Patel Janmashatabdi Samaroh.
5.	21 January, 2014	Shri Ratilal M. Borisagar	Umashankar Joshi ni Kavyarachana : Karna-Krushna.

Guruvandana Granth Sanskruti Vykhanmala.

Shri Manibhai Prajapati (Ex. Librarian and Co-ordinator, Dept. of Library and Information Science, H. N. G. University, Patan) has donated Rs. 1,11,111 on 14 / 6 / 2009 for the lecture series.

Sr. No.	Date / Year	Hon. Speaker	Subject
1.	4 September, 2012	Padmashri Kavi Sitanshu Yashachandra	Granthasanskriti

7.3.6 Budhvariya:

The central library of the university organizes 'budhvariya', on every Wednesday, where vice-chancellor, Pro-vice chancellor, faculty members, librarian discuss various topics. The group discussion helps the students to acquire knowledge other than their study topics.

7.3.7 SPIPA Center:

University has started sub center of SPIPA (Sardar Patel Institute of Public Administration), to prepare students for competitive examination like UPSC and GPSC. The center started functioning from the academic year: 2014-15.

7.3.8 Dissemination of research findings

Lab to Land programme has been initiated to ensure that all innovations achieved in all the laboratories of the Hemchandracharya North Gujarat University are shared with people at the grass root level. The university has established 'Central Instrumentation Facility for Science and Technology Departments with the financial support from UGC. The samples of goods produced in the industries are also tested in the laboratory.

7.3.9 University library system

The campus of University is served by a large central library. All data pertaining to books and journals in the library are available in the computer system of the library. Besides maintaining a collection of print materials, the University Library system also maintains a collection of e- resources on CDs and also subscribes to e-journals under UGC's INFONET programme. Some university departments also have departmental libraries.

7.3.10 Free Hostel facility for ST Students.

Accommodation is provided to Schedule Tribe students both boys and girls free of cost on the university campus in hostels specially established for ST students. Hostel receives financial support from Tribal Development Department of the Government of Gujarat. Such type of hostel facility is provided by only two universities of Gujarat.

7.3.11 University Centre for International Relations

The Hemchandracharya North Gujarat University established the University Centre for International Relations to promote the free flow of students from other nations to HNGU, as well as allow our students to get educated in other nations. The primary motto of the international cell is to provide educational excellence and culturally appropriate ambience to all international students.

7.3.12 National Service Scheme (NSS)

The NSS Unit of the University organizes regular and special camps related to health and hygiene, literacy, etc. These camps are usually held in the campuses of affiliated colleges or in the adopted

villages. The activities in the camps involve various youth-related seminars, workshops and training programmes.

7.3.13 Sports and recreation club

For the promotion of sports, the Hemchandracharya North Gujarat University has established facility for indoor games in the Sardar Patel Administrative Building for university staff. The facilities include badminton court, table tennis courts and chess. The Sport facilities for students are provided by Physical Education Department of the university.

7.3.14 SC/ST cell

A Standing Committee for the welfare of SC/ST has been constituted in the University to look after the welfare of SC/ST students. A Special Cell for the welfare of students belonging to Scheduled Castes and Scheduled Tribes has been set up. The Cell has the responsibilities of Closely monitoring the implementation of the reservation policy of the State Government in admission and hostel accommodation, Collecting data from the university departments and affiliated colleges regarding admission of SC/ST students and hostel accommodation. SC/ST students can contact the SC/ST Cell of the University for any guidance and redressal of grievances.

7.3.15 Women Sexual Harassment Redressal Cell

Sexual Harassment Redressal Cell has been established to promote the well being of the students and staff in the University. A committee has been constituted to deal with cases of sexual harassment. The committee organized various seminars regarding legal awareness about sexual harassment.

7.3.16 Value Education

Vivekananda Centers for Youth Counseling is to be started from January 2015

7.3.17 Anti-Ragging committee

Ragging in any form is strictly prohibited and students who indulge in any such activity will be dealt with seriously by the authorities of the University. Anti Ragging Committee has been established in the University as per the UGC rules and plays a vital role for the welfare of the students. The university has not come across any ragging complaint from any of its departments.

Declaration by the Head of the Institution

I certify that the data included in this Self-Study Report (SSR) are true to the best of my knowledge.

This SSR is prepared by the institution after internal discussions, and no part thereof has been outsourced.

I am aware that the Peer Team will validate the information provided in this SSR during the peer team visit.

(Dr. D. C. Patel)
Registrar (I/c)

Hemchandracharya
North Gujarat University
PATAN-384 265
(Gujarat)



Self Study Report
(Part–C: Departmental Profiles)
for
Assessment & Accreditation

: Submitted to:
National Assessment & Accreditation Council
Bangalore

December 2014

INDEX OF DEPARTMENTAL EVALUATION REPORT

Sr. No	Department	Page No
1	Department of Chemistry	1
2	Department of Commerce and Management	30
3	Department of English	54
4	UGC Centre for Indian Diaspora and Cultural Studies	64
5	Department of Hospital Management	72
6	Institute of Architecture	89
7	Department of Life Sciences	96
8	Department of Mathematics	129
9	Department of Sanskrit and Bhartiya Vidhya	136
10	Department of Biotechnology	147
11	Department of Computer Sciences	165
12	Department of Education	179
13	Department of Journalism and Mass Communication	198
14	Department of Law	204
15	Department of Library and Information Science	227
16	Department of Pharmaceutical Sciences	233
17	Department of Physics & Electronics	262
18	Department of Physical Education & Yoga	270
19	S K College of Business Management	283
20	Department of Social Work	302
21	Jain Academic Education Research centre	308
22	Shivabhai Umedbhai University Library	315

Evaluative Report of the Department of Chemistry

1. Name of the Department : Department of Chemistry
2. Year of establishment : 1993
3. Is the Department part of a School/Faculty of the university?
 - The Department is part of university.
4. Names of programmes offered (UG, PG, M.Phil., Ph.D., Integrated Masters; Integrated Ph.D., D.Sc., D.Litt., etc.)
 - The Department of Chemistry offers four PG basic branches (1) Organic Chemistry (2) Inorganic Chemistry (3) Physical Chemistry (4) Analytical Chemistry. Apart from these, M.Phil (Chemistry), Ph.D (Chemistry) and post graduate Diploma in Drug discovery and Drug Development courses are also offered.
5. Interdisciplinary programmes and departments involved NIL
6. Courses in collaboration with other universities, industries, foreign institutions, etc. NIL
7. Details of programmes discontinued, if any, with reasons NIL
8. Examination System: Annual/Semester/Trimester/Choice Based Credit System ,Semester & CBCS
9. Participation of the department in the courses offered by other departments
 - Selected teachers participate as visiting faculty
10. Number of teaching posts sanctioned, filled and actual (Professors/Associate Professors/Asst. Professors/others)

	Sanctioned	Filled	Actual (including CAS & MPS)
Professor	01	01	03
Associate Professors	02	01	01
Asst. Professors	02	02	----
Other Teaching Assistant	03	03	03

11. Faculty profile with name, qualification, designation, area of specialization, experience and research under guidance

Name	Qualification	Specialization	No. of Years of Experience	No. of Ph.D./ M.Phil. students guided for the last 4 years
Prof. J.J. Vora	M.Sc., Ph.D.	Analytical Chemistry, Organic Chemistry, Coordination Chemistry	26 years (Teaching)	Ph.D. – 8 M.Phil. - 2
Prof. C.P. Bhasin	M.Sc., Ph.D.	Organic Chemistry	>29 years	Ph.D – 04 M.Phil. – 02
Prof. S.S. Sharma	M.Sc., M.Phil, Ph.D., M.Ed.	Physical Chemistry	19 years	Ph.D. – 10 M.Phil. – 04
Dr. K.A. Parmar	M.Sc., Ph.D.	Organic Chemistry	22 years	Ph.D. – 18 M.Phil. – 02

12. List of senior Visiting Fellows, adjunct faculty, emeritus professors

1. Dr. R.N. Jadeja
2. Dr. R.T. Jasrai
3. Dr. P.S. Kalsi
4. Mr. B.J. Mirchandani
5. Prof. I. M. Bhatt
6. Dr. C.K. Modi
7. Dr. Jwalant Vora
8. Dr. Devang Pandya
9. Dr. Sujeet Barankumar
10. Prof. D.I. Brahmhatt

13. Percentage of classes taken by temporary faculty – programme-wise information
1. Paras Patel
 2. Artiben Patel
 3. Parul Trivedi

14. Programme-wise Student Teacher Ratio

M.Sc. – 23:1

M.Phil. – 9:4

Ph.D. -

15. Number of academic support staff (technical) and administrative staff: sanctioned, filled and actual

	Sanctioned	Filled	Actual
Technical Staff	02	02	02
Administrative Staff	01	01	01

16. Research thrust areas as recognized by major funding agencies

17. Number of faculty with ongoing projects from a) national b) international funding agencies and c) Total grants received. Give the names of the funding agencies, project title and grants received project-wise.

No.	Faculty	Name of project	Funding Agency	Total grants Received	Ongoing/ completed
1	Prof. (Dr.) S. S. Sharma	Corrosion inhibition of tin coated steel in acidic Medium	UGC	1,90,000/-	Completed
2	Prof. (Dr.) K.A. Parmar	1. Photochemical survey and chemical screening of some medicinal plants and herbs an approach to the	UGC	87,000/-	Completed

		pharmacological activity.			
		2. Evaluation and pharmacological study of few herbs and plants used in Indian system in medicine	UGC	1,55,000/-	Sanctioned
		3. Evaluation of some potent anti-HIV compounds obtain from medicinally important plants/herbs available around north Gujarat region of India	UGC	1,75,000/-	Sanctioned
		4. Synthesis of bioactive Ag nanoparticles using plants extract and their biological properties as anticancer activity.	UGC One time Research grant	7,30,000/-	Sanctioned
		5. Biosynthesis of nanoparticles using natural products and green approaches in catalytic activity for waste water and effluent treatment.	Ministry of Forest and Environment New Delhi.	39,43,350/-	Submitted

18. Inter-institutional collaborative projects and associated grants received
- a) National collaboration b) International collaboration
- NIL
19. Departmental projects funded by DST-FIST;UGC-SAP/CAS, DPE; DBT, ICSSR, AICTE, etc.; total grants received.
- NIL
20. Research facility / centre with
- state recognition NIL
 - national recognition NIL
 - international recognition NIL
21. Special research laboratories sponsored by / created by industry or corporate bodies
- CIMF – Central Instruments Maintenance Facility was created by UGC funding.
22. Publications:
- Number of papers published in peer reviewed journals (national / international)
 - 108 (since 2009-2014)
 - Monographs
 - Chapters in Books
 - Edited Books
 - Books with ISBN with details of publishers

No.	Title of Research Paper	Name of authors as per order in publication	Journal name	ISSN No	Volume No (Issue)
1	The corrosion and Inhibition of copper and Tin-Lead Alloy in Acidic conditions	Jwalant Vora, Jabali Vora R.T. Jasrai	Journal of Indian Council of Chemist		29
2	Synthesis, Spectral, Thermal Antimicrobial and Catalytic activity of	Parashar Modh and Jabali J.	International Journal of Pharma and		5(2)

	Zn ²⁺ and Cd ²⁺ chelates with valsartan	Vora	Biosciences		
3	Synthesis, Spectral and microbial studies of some novel schiff base derivatives of 2-amino pyridine	K.C. Parmar, J.J. Vora, S.B. Vasava	Journal of chemical and pharmaceutical Research		6(4)
4	Synthesis, spectral and microbial studies of some novel schiff base derivatives of z-amino pyrimidine	K.C. Parmar, J.J. Vora, S.B. Vasava	Journal of chemical and pharmaceutical Research		5(9)
5	Synthesis, Characterization and Antimicrobial Activity of alkaline earth metal complexes	Pandya D.R. and Vora J.J.	Sinica,		3(2), 421-425,
	Synthesis and Antimeicrobial Evaluation of some New Benzimidazole incorporated Chalcone derivatives	J.J.Vora, Keyur P. Trivedi, Rahul S. Kshatriya	International Journal of Chemtech Applications		Vol.2(1), 123-128
6	Synthesis and spectral studies of 2- mercapto -5- methoxy-1- benzimidazole: an imperative medicinal intermediate	J.J.Vora, Keyur P. Trivedi, Rahul S. Kshatriya	Der Chemica Sinica,		3(1), 76-79
7	SyntheSynthesis and spectral studies of 2- mercapto-5-methoxy-1H- benzimidazole: An imperative medicianl intermediate	Jabali J. Vora, Keyur P. Trivedi and Rahul S. Kshatriya	Der Chemica Sinica,		3(1), 76-79
8	Potentiometric Equilibrium Study of Methyl methionine sulfonium chloride.	J. J. Vora, L. S. Bhutadiya	International Journal of Current Chemistry,		2(2), 111-115, 2011

9	An improved synthesis of 2-mercapto-5-difluoromethoxy-1 <i>H</i> -benzimidazole: An important medicinal intermediate Advances in Applied Science Research,	Jabali J. Vora, Keyur P. Trivedi and Rahul S. Kshatriya			2(3), 89-93, (2011)
10	Potentiometric Equilibrium Study of Methyl methionine sulfonium chloride.	J. J. Vora, L. S. Bhutadiya	International Journal of Current Chemistry,		2(2), 111-115,
11	Synthesis and Antimicrobial Activity of Some Novel N-((3-(4-chloro phenyl)-1-phenyl-1 <i>H</i> -pyrazol-4-yl) methylene)-4 <i>H</i> -1, 2, 4-triazol-4-amine Derivatives	Jabali J. Vora, Dinesh R. Patel, Akash R. Patel, Yamini S. Patel	Asian journal of biochemical and pharmaceutical research		1(1), p.p:109-118
12	Synthesis and Antimicrobial Activity of Some Novel N-[3-(SubstitutedAryl) 1-Phenyl-1 <i>H</i> -Pyrazole-4-yl] Methylene triazole Derivatives	Jabali J. Vora, Dinesh R. Patel, Akash R. Patel, Yamini S. Patel	Der pharma Chemica,		vol. 2(3), 257-266
13	Synthesis and biological evaluation of potent benzimidazolone derivative	Jabali J. Vora, Dinesh R. Patel, Nilesh V. Bhimani, Parag V. Ajudia	Der Pharma Chemica,		
14	Conductometric Equilibrium study of Methyl Methionine Sulfonium Chloride.	J. J. Vora, L. S. Bhutadiya	Asian Journal of Chemistry,		22(3), 2477-2479
15	Synthesis, spectral and microbial studies of some novel schiff base derivatives of 4-methyl pyridine-2-amine	J.J. Vora, S.B. Vasava, K.C. Parmar, S.K. Chauhan and S.S. Sharma	E-Journal of Chemsitry,		4, 1205-1210.

16	Degradation kinetics of 2,4-dinitro aniline in presence of irradiated semiconducting oxide	J.J. Vora, S.B. Vasava, K.C. Parmar, S.K. Chauhan, S.S. Sharma and J.A. Patel	International Journal of Chemical sciences,		7(2), 1286-1294
17	Synthesis and antimicrobial activity of some new N- $\{(1E)[3$ -substituted aryl)-1-phenyl-1H-pyrazol-4-yl]methylene}	J.J. Vora, S.B. Vasava, K.C. Parmar, J.A. Patel and M.P. Brahmbhatt, S.S. Sharma	International Journal of Chemical sciences,		7(1), 405-414
18	Kinetic study of application of ZnO as a photo catalyst in heterogeneous media	J.J. Vora, S.B. Vasava, K.C. Parmar, S.K. Chauhan, S.S. Sharma and L.S. Bhutadiya	E-Journal of Chemistry,		6(2), 531-536
19	Synthesis, characterization and antibacterial activity of new series of s-triazine derived with quinolines	J.J. Vora, S.B. Vasava, Asha D. Patel, K.C. Parmar, S.K. Chauhan and S.S. Sharma	E-Journal of Chemistry,		6(1),201-206,
20	A Novel Approach To Macrocyclic Complexes With Mixed Ligands: Synthesis, Characterization, Catalytic and Antimicrobial Studies of Some Alkylene	CP Bhasin, KV Goswami, MP GONGIWA LA	J. Ind. Council Chem,		
21	A solution state study on complexation and thermodynamic parameters of binary	Sangita Sharma, Jayesh Ramani,	Journal of Solution Chemistry		42

	complexes of inner transition metals with piracetam in aqueous and mixed solvents	Dhara Patel,			
22	A study of thermodynamic and interaction parameters of oleic acid with some aprotic solvents at temperatures of 303.15, 308.15, and 313.15 K	Sangita Sharma , Jasmin Bhalodia , Jayesh Ramani & Rignesh Patel	Chemical Engineering Communications, Taylor & Francis,		Vol. 200
23	Kinetic Study of Specific Base Catalyzed Hydrolysis of Ethyl Acrylate in Water–Ethanol Binary System	Sangita Sharma, Jayesh Ramani, Jasmin Bhalodia, and Bijal Vyas	, Russian Journal of Physical Chemistry A, Springer	0036_0 244	87, No. 5,
24	Volumetric, viscometric and excess properties of binary mixtures of 1-iodobutane with benzene, toluene, o-xylene, m-xylene, p-xylene and mesitylene at temperatures from 303.15 to 313.15 K	S. Sharma, Khushbu Thakkar, Paras Patel, Madhuresh Makavana	Advance in Physical Chemistry		Article Id 932103,
25	Viscometric, Acoustic and Spectroscopic Investigation of β -Pinene with Benzene, Toluene, m-Xylene and Mesitylene at 303.15, 308.15 and 313.15 K and Atmospheric Pressure	Jasmin Bhalodia and Sangita Sharma	Journal of Solution Chemistry, Springer,		Vol. 42
26	Volumetric, refractive and FT-IR Behavior of β -Pinene with o, m, p-cresol at 303.15, 308.15 and 313.15 K	Jasmin Bhalodia and Sangita Sharma	Journal of Molecular Liquids, Elsevier		Vol. 193
27	Fluoride and fluorosis in	J. Ramani, J.	Research		Vol. 3,

	contax to gujarat state of india: a review	Bhalodia, Khusbu Thakkar, S. Sharma	Journal of Pharmaceuti cal, Biological and Chemical Science,		85-94
28	Complexation behavior and thermodynamic parametric study of Lanthanone(III) ions with n,n-dimethylbiguanide	J. Ramani, J. Bhalodia, M Neog, S. Sharma	Der Chemica Sinica		Vol. 3, 561-568
29	A dechlorination pathway for synthesis of horn shaped carbon nanotubes and its adsorption properties for CO ₂ , CH ₄ , CO and N ₂ S. Y.	Sawant, R. S. Somani, H. C. Bajaj, S. S. Sharma	Hazardous Materials		J. Vol. 227-228, 317-326
30	Synthesis and antimicrobial evaluation of some novel 2-(4-chlorophenylimino) thiazolidin-4-one derivatives	H. B' Bhatt and S. Sharma J. Korean	Chem. Soc.,		Vol. 56, 341-347
31	Synthesis, Antibacterial, Antifugal and Anti-Tuberculosis Activities of some new 2-(5-Methylbenzo(D)Thiazol-2-Ylimino) Thiazolidin-4-one based Heterocylces	H. B. Bhatt, S. Sharma*	Instasci. J. Of Chemistry		33-42
32	Volumetric, viscoimetric and ultrasonic studies on binary mixture of oleic acid with alkyl esters at 303.15, 308.15 and 313.15K	Sangita Sharma, Jasmine Bhalodiya, Jayesh Ramani and Rignesh Patel	Internationa l Journal of Physical Science,		Vol.7(8) , 1205-1214
33	Isocratic Liquid Chromatographic Method for Analysis of Amisulpride in Pharmaceutical Preparations	Madhurja Neog, Rikesh Patel and Sangita Sharma*	Internationa l Journal of PharmaTech Research,		Vol. 3(4), 1909-1915

34	Evaluation of Stability of Complexes of Inner Transition Metal Ions 2-Oxo-1-pyrrolidine Acetamide and Role of Systematic Errors	Sangita Sharma, Jayesh Ramani, Dhara Patel, Ketan Patel and Mahesh Kadiya	E-Journal of Chemistry		Vol.8(4), 1965-1971
35	Density, excess molar volume and refractive indices of β -pinene with o, m, p-xylene and toluene at 303.15, 308.15 and 313.15K	Sangita Sharma, Jasmine Bhalodiya, Jayesh Ramani and Rignesh Patel	Physics and Chemistry of Liquids,		Vol.49(6), 765-776
36	PM3, Ab Initio and Solution Studies of some Transition Metal Complexes of Creatinine	Sangita Sharma, Ashish Patel, Jayesh Ramani and Jasmine Bhalodiya	J. Indian Council Chemists		vol. 28, No. 1, 44-48
37	Synthesis, Characterization and Antimicrobial Activity of some Transition Metal Complexes (Mn, Co, Zn, Ni) With L-Proline and Kojic Acid	Sangita Sharma, Jayesh Ramani, Jasmine Bhalodiya, Neha Patel, Khushbu Thakkar and Rajesh Patel	Advances in Applied Science Research,		Vol.2(4), 374-372
38	Kinetic and Mechanistic Study of Oxidation of Catechine	Sangita Sharma, Jayesh Ramani, Jasmine Bhalodiya and Falguni Thakkar	Der Chemica Sinica,		Vol. 2(4), 140-151

39	A study on Corrosion of Tin coated steel in 0.5M Monochloroacetic acid in presence of carbonate and bicarbonate inhibitors by potential measurement method	Sangita Sharma, Kinnari H. Parikh, and Naveen Kumar	Ultra Chemistry		Vol. 7(2), 213-218
40	Cathodic protection of tin-coated steel in monochloroacetic acid (0.5 mol dm ⁻³) in presences of chromate and dichromate	Sangita Sharma, K. H. Parikh, M. Neog	J. Indian Chem. Soc.,		Vol. 88, 603-606
41	New ternary transition metal complexes of 2- {[2-aminophenyl)imino]methyl}phenol and Metformin: synthesis, Characterization and antimicrobial activity	Sangita Sharma, Jayesh Ramani, Dipika Dalwadi, Jasmin Bhalodia, Neha Patel, Dhara Patel, and Rajesh Patel	E-Journal of Chemistry,		Vol 8(1), 361-367
42	Spectrophotometric Estimation of Sulfadoxine in Pharmaceutical Preparations	Sangita Sharma, Madhurjya Neog, Vipul Prajapati, Hiren Patel and Dipti Dabhi	E-Journal of Chemistry,		Vol7(4), 1246-1253
43	Synthesis, Characterization and antimicrobial Activity of Ternary Cr(VI) and Fe(III) Metal Complexes of 2- {[2-aminophenyl)imino]methyl}phenol and Metformin	Sangita Sharma, Jayesh Ramani, Dipika Dalwadi, Jasmin Bhalodia, Dhara Patel, and Rajesh Patel	Journal Ultra Science,		Vol.6(2), 211-220

44	Computer Augmented Modeling Studies on Complexes of Lanthanone ions with Creatinine in Dioxane-Water Mixtures	Sharma Sangita, Patel Ashish, Bhalodia Jasmin, Ramani Jayesh and Vora J.J.	Research Journal Of Chemistry and Environment		Vol.14(2), 45-49
45	Application of Singh-Jha Equation in the Evaluation of b^* Parameter of Laidler-Landskoener Equation in the Hydrolysis of Vinyl Acetate	Sangita Sharma, Bijal Vyas, Falguni Thakkar, Ketan Patel and J. J. Vora	E-Journal of Chemistry ,		Vol7(4), 1170-1173
46	Spectrophotometric Oxidation of Catechol: A Kinetic Study	Sangita Sharma, Falguni Thakkar and Bijal Vyas	Int. J. of Pure & Applied Chemistry		Vol.5(1) , 55-59
47	Development and Validation of Spectrophotometric Methods for Estimating Amisulpride in Pharmaceutical Preparations	Sangita Sharma, Madhurjya Neog, Vipul Prajapati, Hiren Patel and Dipti Dabhi	Analytical Sciences,		Vol.26, 485-489
48	Arsenic pollution and toxicity: an update review	Sangita Sharma, Chirag patel, Navin Kumar and Jayshre Patel	Asian J. Chem And Environmental Research		Vol. 3(1), 86-90
49	A study of the formation constants of ternary and quaternary complexes of some bivalent transition metals,	Sangita Sharma, Dipika Dalwadi and Madhurjya	J. Serbian Chemical Society		75(1), 75-82.

		Neog,			
50	Solution state studies on thermodynamic parameters and complexation behavior of inner transition metal ions with creatinine in aqueous and mixed equilibria Res.	Sangita Sharma, Ashish Patel, Jasmin Bhalodia, Jayesh Ramani	J. Iran. Chem.		Vol.2, 267-275
51	Effect of systematic errors and solvent on stability of complexes of inner transition metal ions with creatine: A computer augmented modeling study	Sharma Sangita, Patel Ashish, Patel Ketan and Sharma Anamika	Ultra Science		Vol.5(3) , 341-348
52	Degradation Kinetics of 2,4-dinitroaniline in presence of irradiated semiconducting oxide	J. J. Vora*, S. K. Chauhan, K. C. Paramar, S. B. Vasava, S. Sharma and J. A. Patel,	Int. J. Chem. Sci.		Vol. 7(2), 1286-1294
53	Synthesis, Characterization and Antibacterial Activity of a New N'-{(1E)-{Substituted aryl} -1-Phenyl – 1H- Pyrazole – 4- YL] Methylene} isocotinohydrazide Derivatives	J. J. Vora*, S. B. Vasava, K. C. Paramar, S. S. Sharma, J. A. Patel and M. P. Brahmabhatt			Inst. J. Chem. Sci., Vol. 7(1), 403-414
54	Densities and Viscosity Study of binary liquid mixtures of eucalyptol with some methanol, ethanol, 1- propanol, 1- butanol and 2- methylpropan-1-ol at	Sangita Sharma, Pragnesh B. Patel, Rignesh S. Patel and J. J. Vora			J. Indian Chem. Soc., Vol. 86, 419-424

	303.15 308.15 and 313.15K				
55	A solution study of complex formation of some Diamine with Lanthanone	J. J. Vora*, D. R. Patel, Asha D. Patel, Kanu Patel, Sangita Sharma, Laxaman S. Bhutadia and Sunil B. Vasava	E-Journal of Chemistry,		6(1), 2270-272
60	Synthesis and biological activity of novel 1,3,5-trisubstituted 1,2,4-triazole derivatives	Kokila A. Parmar* Bharat Suthar, Sarju Prajapati and Arun Suthar	Journal of Heterocyclic Chemistry, Article, Wiley Inter Science		46,
56	Synthesis, characterization and antimicrobial evaluation of novel 4-pyrrol-1-yl-5,6,7,8-tetrahydro-pyrido [4',3':4,5]thieno[2,3-d]pyrimidine derivatives.	Kokila A. Parmar* Bharat Suthar, Arun Suthar and Abhay Maheta	Journal of Heterocyclic Chemistry, Wiley Inter Science		46,
57	HP-TLC aided phytochemical fingerprint analysis as a tool for evaluation and antiviral activity using Hela cell cultures of Bauhinia variegata plant.	Kokila A. Parmar* S. N. Prajapati	The Asian journal of Experimental Chemistry		4 No 1&2
58	Synthesis and antibacterial evaluation of some novel 2-arylaamino-4-phenyl-thiazolyl derivatives.	Kokila A. Parmar* Bharat G. Suthar and Sarju Prajapati	Bull. Korean Chem. Soc. (Korea)		Vol. 31, No.4,
59	Anti-Viral in HEL Cell, Hela Cell cultures, antibacterial and anti oxidant activity of <i>Acacia</i>	Kokila A. Parmar* Anup N. Patel, Sarju	Journal of Chemical and Pharmaceuti		Vol.2(4)

	<i>arabica</i> seeds extracts by the use of DPPH free radical method.	N. Prajapati and Rakesh I. Patel	cal Research		
60	Phytochemical Screening of <i>Randia dumetoram</i> plant extract for the antioxidant activity by DPPH method and their antibacterial and antiviral activities.	Kokila A. Parmar* Sarju N. Prajapati and Amit P. Jani	International Journal of Chemical Science		Vol.8(2)
61	Preliminary phytochemical screening and study of anti-viral activity and anti-bacterial activity of <i>Tephrosia purpurea</i> flowers.	Kokila A. Parmar* Sarju N. Prajapati	Journal of Life science Leaflets:		Vol.-1
62	Synthesis, characterization and biological evaluation of 3-chloro-1-[3,6-diphenyl]-[1,2,4]triazole[3,4-b][1,3,4]thiadiazole)-4-substituted-aryl-azetidines.	Kokila.A.Parmar* Dhaval. J. Solanki, and Rekha M.Patel	Research journal of chemistry and Environment,		Vol.-14, No.-1,
63	Synthesis, characterization and biological evaluation of some novel heterocyclic compounds having sulphamido moiety.	Kokila A. Parmar* Dhaval. J. Solanki and Devang .J. Solanki	Journal of Der Pharma. Chemica.		Vol.-2(5)
64	Effective use of ferric sulphate and ferric chloride in treatment of dairy Industries wastewater.	Kokila A.Parmar* and Yogesh Dabhi	Asian Journal of Chemistry, (International Peer Reviewed Research Journal of Chemistry)		Vol. 22, No.10
65	Synthesis and antibacterial evaluation of some novel acetonitrile	Kokila A. Parmar* Sarju	Journal of Archives of Applied		Vol. 3(1),

	and imidazoline derivatives.	Prajapati, Rinku. Patel, and Mahrshi Shukla	Science Research.		
66	Studies on cyanopyridones and isoxazoles ring system in the synthesis of novel bioactive compound.	Kokila A. Parmar* Sarju Prajapati, S. A. Joshi, K.V. Goswami and A. N. Patel	Journal of Der Pharma. Chemica.		Vol. 2(1),
67	A versatile approach for the synthesis of some new [1,2,4]triazolo derivatives of 1,3,4 thiadiazine and their biological activities.	Kokila A. Parmar* Sarju Prajapati, Rinku Patel, and Sejal. A. Joshi	Journal of Ultra Chemistry,		Vol. 7(1)
68	Anti-viral and in-vitro free radical scavenging activity of leaves of <i>Rubia-cardifolia</i> .	Kokila A. Parmar* and Sarju Prajapati	International Journal of Phyto medicine. Elsever		Vol 3,
69	Efficient synthesis and biological evaluation of 3-(phenyl)-6-(4-amino phenyl)[1,2,4]triazolo[3,4-b][1,3,4] thiazole and their Schiff base derivatives.	Kokila A. Parmar* Sarju Prajapati, Rinku. Patel, Sejal. A. Joshi and Rekha Patel	International Journal of ChemTech Research.		Vol. 3, No. 2,
70	A facile and expeditious approach for synthesis of 2-azetidinone derivatives with microbial activity.	Kokila A. Parmar* Viral Modi, Sarju Prajapati and Rinku Patel	Asian Journal of Biochemical and Pharmaceutical Research.		Vol. 1(2),

71	Synthesis and characterization of some 4-thiazolidinones derivatives based on PFP and their antibacterial activity.	Kokila A. Parmar* R. I. Patel, H. C. Sonara and Viral Modi	International Journal of Research in Chemistry and Environment.		Vol. 1(1),
72	A simple and efficient procedure for synthesis of biologically active 1,2,4-triazo-[3,4-b]-1-3-4-thiadiazole-2-aryl-thiazolidine-4-one derivatives	Kokila A. Parmar* Rinku P. Patel and Sarju N. Prajapati, Rekha Patel	Research Journal of chemical sciences		Vol. 1(1),
73	Effective use of Ferrous sulphate and alum as a co-agulant in treatment of dairy industries waste water	Kokila Parmar* Rinku Patel, Sarju Prajapati and Yogesh Dabhi	ARPJN Journal of Engineering and Applied science	1819-6608	Vol. 6, No. 9,
74	Synthesis, characterization and antimicrobial activity of substituted 2-azetidinones derivatives based on 1-N-phenyl-3-phenyl-4-formyl pyrazole (PFP)	Kokila A. Parmar* Sejal A. Joshi, Rinku P. Patel and Sarju N. Prajapati	Der Chemica Sinica,		Vol. 3(5),
75	Synthesis and antimicrobial activity of novel 3-chloro[1-(3,6-(diphenyl)[1,2,4]triazolo[3,4b][1,3,4]thiadiazole)]-4-(3,4-diethoxyphenyl)-azetidin-2-one and their derivatives)	Kokila Parmar*, Rekha Patel Rinku Patel and Sarju Prajapati, Sejal Joshi	Journal of Applied Pharmaceutical Science		Vol. 02(01),
76	Spectral Analysis and Biological screening of some new derivatives of Piperazine-Pyrazoline merged Compounds	K. A. Parmar* ¹ , J. R. Vihol, H. C. Sonara and Y.M. Dabhi	Pelagia Research Library Der Pharmacia Sinica,		Vol. 3(2)

77	Synthesis, Spectral studies and Antibacterial Screening of Some Novel Derivatives of Pyrazoline based on Chalcones	K. A. Parmar*, Jayendrasingh R. Vihol, Yogesh M.Dabhi, Shashikant D. Sutariya	Journal of Chemical and Pharmaceutical Research		Vol.4(3)
78	Pyrazoline-Piperazine merged Compounds: Synthesis, Spectral analysis and Antibacterial Evaluation	K.A. Parmar*, J. R. Vihol, Y.M. Dabhi, V.B.Modi	Journal of Chemical, Biological and Physical Sciences		Vol. 2(2),
79	Synthesis and antimicrobial activity of substituted 2H-pyrrole-2-ones derivatives based on 1-N-phenyl-3-phenyl-4-formyl pyrazole (PFP)	Kokila Parmar*, Shashikant Sutariya, Maharshi Shukla and Kalpeshgiri Goswami	Journal of Chemical and Pharmaceutical Research,		Vol. 4(7), (2012)
80.	Quantitative Application of NMR in Ropivacaine Hydrochloride and its Related Impurity-A with Correlation by Alternate Techniques	Kokila Parmar* Anil Mahato, Rinku Patel and Sarju Prajapati	International Journal of Chem Tech Research	0974-4290 CODE N (USA): IJCRGG	Vol. 5(1),
81	Efficient synthesis and evaluation some new s-triazine derivatives and their microbial screening.	K.A. Parmar*, Sarju N. Prajapati, Shashikant Sutariya and Rakesh I. Patel	Journal of Chemical Biological and Physical Sciences,	2249-1929 CODE N (USA): KBPAT	Vol. 3(1),
82	Synthesis, characterization and microbial screening of 2-(4-chlorophenyl-1,3,4-oxadizoly)-5-thio-4-(cyclohexaylamino)-6-(arylamino)-s-triazine	K.A.Parmar*, S.N. Prajapati and Chetan j .vasava	Journal of Chemical Biological and Physical Sciences,	2249-1929 CODE N (USA): KBPAT	Vol.3(3)

83	Synthesis, characterization and antibacterial activity of 2-(4-methyl,7-hydroxycoumarine)-4-(cyclohexayl amino)-6-(arylamino)-s-triazine	Kokila A. Parmar*, Chetan R. Patel and Sejal A. Joshi	Der Pharmacia Letter,	0975-5071 CODE N (USA): DPLEB 4	Vol. 5(1),
84	Synthesis, characterization and biological evaluation of 2-(4-methyl,7-hydroxycoumarine)-4-(4-flouro-3-chloroamino)-6-(arylamino)-s-trizine	K. A. Parmar*, M. B. Shukla and S. A. Joshi	Journal of Chemical and Pharmaceuti cal Research	0975-7384 CODE N (USA) JCPRC 5	Vol. 5(1),
85	Preliminary phyto-chemical, pharmacognostical and microbial screening of <i>Achyranthes aspera</i> (Amaranthaceae)	K. A. Parmar*, S. N. Prajapati, V. V. Chauhan and C. R. Patel	Journal of Natural Product Resources,	2231-3184 CODE N (USA) JNPPBI	Vol. 3(1),
86	Synthesis, Structural Elucidation and Anti Microbial Screening of N-(4-aryl amine)-2-{[4-phenyl-5-(pyridine-4-yl)-4H-1,2,4-triazol-3-yl]sulfanyl}acetamide Derivatives.	Kokila.A. Parmar*, Jyotindra B. Mahyavansi, Anil K.Mahato	Indian Journal of Applied Research,	2249-555x	Vol. 4(1),
87	Synthesis and spectral studies of 1,N-acetyl-3-aryl-5-(1',N-phenyl-3'-o-methoxyphenyl-pyrazole-4'-yl)-pyrazoline derivatives and their expected biological activity.	Kokila A. Parmar* Rinku P. Patel and Sarju N. Prajapati	Asian Journal of Research chem.,:	0974-4169	Vol. 5(5)
88	Synthesis, characterization and antibacterial screening of 2-[(5-methoxy-1H-benzimidazol-2-yl)sulfanyl]-N-phenyl	K. A. Parmar*, M. B. Shukla and K.V. Goswami	Arkivoc, ARKAT,		(2013-14)

	acetamide (Accepted)				
89	Synthesis and antimicrobial activities of 2-(3,4,5-trimethoxyphenyl)-5-{{(1-arylamino)-2-oxoethyl}-mercapto-1,3,4-oxadiazole (Accepted)	K. A. Parmar*, M. B. Shukla	Arkivoc, ARKAT,		(2013-14)
90.	Effectiveness of chitosan as coagulant acid for waste water treatment. (Accepted)	Kokila A. Parmar*	Journal of Chemistry and Environment.		(2013)
91.	Synthesis, characterization and antimicrobial activity of some new thiosemicarbazone derivatives. (Accepted)	Kokila A. Parmar* Sarju Prajapati, Rinku. Patel, and Sejal. A. Joshi	Journal of Ethiopian Chemical Society. (Ethopia)		(2013)
92.	A versatile approach for the synthesis of some new [1,2,4]triazolo derivatives of 1,3,4 thiadiazepine and their biological activities. (Accepted)	Kokila A. Parmar* Sarju Parajapati,	E-Journal of Chemistry, India		
93.	Synthesis and antimicrobial studies of some 1, N-phenyl-3-aryl-5-(1',N-phenyl-3'-o-methoxyphenyl-pyrazole-4'-yl)-pyrazoline derivatives. (Accepted)	Kokila A. Parmar* Sejal A. Joshi, Kalpesh Goswami and Kamlesh Kundaria	Journal of Korean Chem. Soci., Korea		(2013)
94.	Synthesis, characterization and antimicrobial activity of substituted 2-Azetidinones derivatives based on 1-N-phenyl-3-phenyl-4-formyl pyrazole	Kokila A. Parmar* S. D. Sutariya, A. N. Mahato and Kalpesh Goswami	E-Journal of chemistry, India		(2013)

	(PFP) (Accepted)				
95.	Effectiveness of <i>Moringa oleifera</i> as Natural Coagulant aid for west water treatment of dairy industry	Kokila A. Parmar* and Sarju N. Prajapati	Journal of water and Health,		(2013)
96.	Synthesis and Antibacterial Evaluation of some Pyrazoline-Piperazine merged Compounds (III)	Kokila Parmar*, Jayendrasingh Vihol, Kalpeshgiri Goswami, Vaishali Chauhan	Research Journal of Pharm Ceutical , Biological and Chemical Sciences,.	0975-8585	Vol. 3(2),
97.	Ylidenemalonitriles as a key Precursor for the Synthesis of several Chromene based Heterocyclic Compounds (Accepted)	Kokila Parmar* Prakash Sutariya, Sarju Prajapati,	Arkivoc, ARKAT		(2014)
98	Characterization of Antioxidant, antiviral and anti tuberculosis activity of <i>Zizyphus jujube</i> leaves (Accepted)	Kokila Parmar* Sarju Prajapati,	Journal of Plant soil, Wiley science		(2014)
99	Phytochemical, Pharmacognostical and antibacteriac screening of <i>Areca catechu</i>	K. A. Parmar*, V. V. Chauhan and C. R. Patel	Journal of Natural Product Resources	2231-3184 CODE N (USA) JNPPBI	Vol.4(2)
100	Synthesis structural elucidation and antimicrobial screening of s-triazinyl substituted aryl amine derivatives	Kokila.A. Parmar*, Jyotindra B. Mahyavansi	Journal of Chemical biological and physical sciences	2249-1929	Vol. 3(3),
101	Synthesis, structural elucidation and biological activity of pyrimidine based Azetidiones Derivatives	Kokila.A. Parmar*, Chetan J Vasava and Ranjit	European Journal of Medicinal Chemistry		

	(communicated)	k.Patel			
102	Development & Validation of HPLC method for analysis of some antihypertensive agents in their pharmaceutical dosage forms.	Kokila.A. Parmar* and Jignesh shah	Journal of Drug Delivery and therapeutics,	2250-1177	vol.4(2),
103	Qualitative and quantitative application of NMR in Rilmenidine dihydrogen phosphate API and its related impurity-B with correlation by alternate technique	Kokila.A. Parmar*,Anil Mahato and Jignesh M.Shah	International Journal of Pharmaceutical review & research	0976-044X	Vol.26
104	Comparative study of determination of glutaric acid in glutaric anhydride by NMR and GC method (communicated)	Kokila.A. Parmar*,Anil Mahato and Jignesh M.Shah	American Chemical Science Journal		(2014)
105	Method Development Method validation and Method Equivalency report on Determination of Triethanolamine content in drug intermediate By qNMR (communicated)	Kokila.A. Parmar*,Anil Mahato and Jignesh M.Shah	Journal of Analytical Chemistry		(2014)
106	Synthesis and Pharmacological Aspects of Some Novel N-(4-(2-(Methyl(3-Methyl -1-Phenyl-1H-Pyrazol-5-yl)Amino)Thiazol-4-yl)Phenyl)(Alkyl)Amide derivatives.	Kokila.A. Parmar* Ranjit K Patel, Ashwin D Acharya and Jyotindra Mahyavanshi	International journal of Scientific Research	2277-8179	Vol.3(6)
107	Mass Compatible method development for alixarine hemifumarate and identification of addnot impurity in present of lactose excipient.	Kokila.A. Parmar* Jignesh M.shah	American Journal of pharm Tech Research.	Ajptr.	Vol,(6)

108	Simultaneous Estimation of Aliskiren and Valsartan by Ratio Spectra Derivative Spectrophotometry Method in their Fixed Dosage Forms	Kokila.A.Parmar* Jignesh M.shah	International Journal of Chem Tech Research	0974-4290 CODE N (USA): IJCRG	Vol.6, No.2
-----	---	---------------------------------------	---	--	----------------

- Number listed in International Database (For e.g. Web of Science, Scopus, Humanities International Complete, Dare Database - International Social Sciences Directory, EBSCO host, etc.)
- Citation Index – range / average
- SNIP
23. Details of patents and income generated
- NIL
24. Areas of consultancy and income generated
- NIL
25. Faculty selected nationally / internationally to visit other laboratories / institutions /industries in India and abroad
- NIL
26. Faculty serving in
- a) National committees b) International committees c) Editorial Boards d) any other (please specify)
- Reviewer of several national and international journals (Elsevier, Academic Journal, Wiley, Springer, ICC, ICS, NISCAIR)
27. Faculty recharging strategies (UGC, ASC, Refresher / orientation programs, workshops, training programs and similar programs).
- Workshops/Conferences/Seminars -25
28. Student projects **Nil**
- percentage of students who have done in-house projects including inter-departmental projects
 - percentage of students doing projects in collaboration with other universities /industry / institute
29. Awards / recognitions received at the national and international level by
- Faculty **Nil**
 - Doctoral / post doctoral fellows
 - Students
30. Seminars/ Conferences/Workshops organized and the source of funding (national /international) with details of outstanding participants, if any.

- Convener : 28th Annual Conference of Indian Council of Chemists – Agra – 7 to 10 Nov. 2009
- Convener : National Conference – 1-2 February-2011

31. Code of ethics for research followed by the departments

- NIL

32. Student profile programme-wise:

Name of the Programme (refer to question no. 4)	Applications received	Selected		Pass percentage	
		Male	Female	Male	Female
M.Sc.	Central Admission	25	15	100	100
M.Phil.	Central Admission through Entrance Examination	14	6	100	100
Ph.D.	Central Admission through Entrance Examination	-	-	-	-

33. Diversity of students

Name of the Programme (refer to question no. 4)	% of students from the same university	% of students from other universities within the State	% of students from universities outside the State	% of students from other countries
M.Sc	-	-	-	NIL
M.Phil.	4	-	-	NIL
Ph.D.	4	2	2	NIL

34. How many students have cleared Civil Services and Defense Services examinations, NET, SET, GATE and other competitive examinations? Give details category-wise.

35. Student progression

Student progression	Percentage against enrolled
UG to PG	NIL
PG to M.Phil.	47:9
PG to Ph.D.	47:10
Ph.D. to Post-Doctoral	NIL
Employed	
<input type="checkbox"/> Campus selection	0
<input type="checkbox"/> Other than campus recruitment	100%
Entrepreneurs	0

36. Diversity of staff

Percentage of faculty who are graduates of the same university	50
from other universities within the State	
from universities from other States	50
from universities outside the country	

37. Number of faculty who were awarded M.Phil., Ph.D., D.Sc. and D.Litt. during the assessment period

- Paras Patel
- Parul Trivedi

38 .Present details of departmental infrastructural facilities with regard to

- a) Library
 - University central library facility available in university campus.
 - b) Internet facilities for staff and students
 - Only for Faculty
 - c) Total number of class rooms
 - 08
 - d) Class rooms with ICT facility
 - Three classrooms with multimedia projectors.
 - e) Students' laboratories
 - 06
 - f) Research laboratories
 - 04
39. List of doctoral, post-doctoral students and Research Associates
- a) from the host institution/university - Nil
 - b) from other institutions/universities -Nil
40. Number of post graduate students getting financial assistance from the university.
- NIL
41. Was any need assessment exercise undertaken before the development of new programme(s)? If so, highlight the methodology.
- NIL
- 42 .Does the department obtain feedback from
- a. faculty on curriculum as well as teaching-learning-evaluation? If yes, how does the department utilize the feedback?
 - The head of the department is the chairperson of the board of studies of H.N.G.University and hence for M.Sc the faculty member's suggestions are quite important in curriculum development and the suggestions for M.Phil curriculum are almost directly adopted.
 - b. students on staff, curriculum and teaching-learning-evaluation and how does the department utilize the feedback?
 - Teaching faculty takes into account of suggestions from students and creative suggestions are considered in the
 - c. alumni and employers on the programmes offered and how does the department utilize the feedback?
 - Senior persons from industries are invited for curriculum development.

- 43 .List the distinguished alumni of the department (maximum 10)
1. Dr. Asha D. Patel ,Executive Council member HNGU
 2. Dr. Dushyant Joshi
 3. Dr. Yogesh Dabhi , I/C Principal R J Shah Science College
 4. Dr. Poonam Malviya , R&D Zydus Cadila
 5. Dr Dushyant Patel
 6. Dr. Hemant Patel , R&D Dept Sun Pharma
 7. Dr. Chandrakant Patel, R&D, Torrent Pharma
 8. Dr. R.S. Dave , Head, Department of Chemistry, Science College Pilvai
 9. Dr. A.S.Prajapati, Gujarat College, Ahmedabad.
 10. Dr. D.R.Patel, Principal, Science College Pilvai
44. Give details of student enrichment programmes (special lectures / workshops / seminar) involving external experts.
- Special Invited Lecture series
 1. Prof. P. S. Kalsi
 2. Prof. D. I. Brahmbhatt
45. List the teaching methods adopted by the faculty for different programmes.
1. Use of multimedia presentations
 2. Use of models
 3. Classical classroom teaching
46. How does the department ensure that programme objectives are constantly met and learning outcomes are monitored?
- At End of Each month, Students are asked to submit in writing the topics covered in that period.
47. Highlight the participation of students and faculty in extension activities.
1. Sports coordinators
 2. Cultural coordinators
 3. Other activities
- To carry out various extracurricular activities
48. Give details of “beyond syllabus scholarly activities” of the department.
- All Students take part in the Seminar/workshops/conference.
 - Participate in exam like NET, SLET, Minaxi Lalit etc.
49. State whether the programme/ department is accredited/ graded by other agencies? If yes, give details.
- NIL
50. Briefly highlight the contributions of the department in generating new knowledge, basic or applied.
- NIL

51. Detail five major Strengths, Weaknesses, Opportunities and Challenges (SWOC) of the department.
- Strengths: I) CIMF Cell for Instrumentation
 II) Three full fledged branches of M.Sc and part time M.Phil course in spite of limited faculty.
 III) University Industry Linkages Cell for developing relations with industries
- Weakness: I) Shortage of faculty
 II) Department library not available
 III) Laptop not issued for teaching purpose to faculty
- Opportunities:
- I. On arrival of new faculty more courses of industrial relevance may be started.
 - II. On arrival of regular faculty department will be eligible for program like SAP, FIST etc.. there by creating new instrumental and infrastructure facilities.
- Challenges:
- I. Sanctioning more teaching posts
 - II. Sanctioning more non teaching posts
52. Future plans of the department.
- I. Developing advanced research centre
 - II. To develop centre for commercial analyses of samples for the benefit of society.
 - III. To start new innovative courses for fulfill the requirement of Industry.

Evaluative Report of the Department of Commerce & Management

1. Name of the Department: Department of Commerce & Management
2. Year of establishment: November 1996
3. Is the Department part of a School/Faculty of the university?
The department is part of Faculty of Management, it is a Post Graduate Department of the University.
4. Names of programmes offered (UG, PG, M.Phil., Ph.D., Integrated Masters; Integrated Ph.D., D.Sc., D.Litt., etc.)
M.B.A., MCom., M.Phil (Commerce), Ph.D.
5. Interdisciplinary programmes and departments involved
No interdisciplinary programmes are offered in the department.
6. Courses in collaboration with other universities, industries, foreign institutions, etc. Nil
7. Details of programmes discontinued, if any, with reasons
No programmes being discontinued in last five years.
8. Examination System: Annual/Semester/Trimester/Choice Based Credit System
Semester examination system in M.B.A., M.Com. and M.Phil.
Choice Based Credit System is also there in M.Com. programme.
9. Participation of the department in the courses offered by other departments
The department is offering Yoga and Health as a subject which is being taught by faculty of Yoga Centre (Department of Physical Education)
Faculty of Commerce & Management department also going to other department as a visiting faculty to engage sessions of
10. Number of teaching posts sanctioned, filled and actual
(Professors/Associate Professors/Asst. Professors/others)

	Sanctioned	Filled	Actual (including CAS and MPS)
Professor	01	01	01
Associate Professor	01	01	03
Assistant Professor	02	02	01
Other(Guest Faculty)	-	03	03

Faculty profile with name, qualification, designation, area of specialization, experience and research under guidance

Name	Qualifica tion	Designatio n	Specializa tion	No. of Years of Experie nce	No. of MPhil/ PhD Student Guided/ Ongoing for last 4 years
Dr. B.A.Prajapati	M.Com., FDPM, (IIM-A) Ph.D.	Professor	Finance & Account	18 Yrs.	Ph.D.: 7+8
Dr. N. H. Bhatt	B.Sc., M.B.A., Ph.D.	Associate Professor	Marketing	17 Yrs.	Ph.D.: 3+4 M.Phil.: 17
Dr. K. L. Rathod	B.E., M.B.A., Ph.D.	Associate Professor	Marketing	17 Yrs.	Ph.D.: 0+6
Dr. A. G. Modi	B.B.A, M.B.A., Ph.D.	Associate Professor	Finance	14 Yrs.	Ph.D.: 1+7
Dr. K K Patel	B.B.A, M.B.A., Ph.D.	Assistant Professor	Finance	8 Yrs.	M.Phil.: 17+3

12. List of senior Visiting Fellows, adjunct faculty, emeritus professors

Following is the list of regular guest faculty in the department:

1. Mrs. Gayatri B. Vyas [B.Sc., M.B.A., Ph.D.(Pursuing)]

2. Mrs. Jyoti I. Ganchi [B.E., M.B.A., Ph.D.(Pursuing)]

3. Mrs. Dipali A. Patel [B.V.Sc., M.B.A.]

13. Percentage of classes taken by temporary faculty – programme-wise information

M.B.A. : about 50%

M.Com.: almost 50%

M.Phil.: 100%

14. Programme-wise Student Teacher Ratio

25:01

15. Number of academic support staff (technical) and administrative staff: sanctioned, filled and actual

Sanctioned	Filled	Actual
1 Clerk	1	1 Permanent
1 Technical assistant	1	1 Daily Wages
1 clerk in Library	1	1 Daily Wages
1 Peon	2	2 Daily Wages

16. Research thrust areas as recognized by major funding agencies

UGC, ICSSR

17. Number of faculty with ongoing projects from a) national b) international funding agencies and c) Total grants received. Give the names of the funding agencies, project title and grants received project-wise.

Prof. B.A. Prajapati

Economic and social issues confronting the marginalized social groups of Gujarat state, ICSSR, New Delhi. Grant received – Rs.12,48,000/-

Dr. N H Bhatt

Women's Empowerment : A study of Sakhi Mandal Yojana (SMY) & Its Impact on Women of Rural Area of Patan District, UGC, New Delhi, Grant received – Rs.1,30,000/-

Dr. A. G Modi

A study on Consumer Satisfaction from Healthcare organizations : Promoting Healthcare Consumerism at Gujarat, Ministry of Consumer Affairs, New Delhi, Grant received – Rs.379000

18. Inter-institutional collaborative projects and associated grants received

a) National collaboration

b) International collaboration

NA

19. Departmental projects funded by DST-FIST; UGC-SAP/CAS, DPE; DBT, ICSSR, AICTE, etc.; total grants received.
As mentioned in Sr. No. 17
20. Research facility / centre with NA
- state recognition
 - national recognition
 - international recognition
21. Special research laboratories sponsored by / created by industry or corporate bodies

NA

22. Publications:

- Number of papers published in peer reviewed journals (national / international)

Dr. B A Prajapati

No .	Title of Research Paper	Journal name	ISS N No	Volum e No (Issue)	Pag e No	Year of Publicatio n
1	A study of performance of the SHG bank linkage programmed in Gujarat.	Zenith International Journal of Business Economics & Management Research	2249 - 8826	3 (5)		2013-14
2	A study on performance of the SHG bank linkage programme in Gujarat.	Zenith International Journal of Business Economics & Management	2249 - 8826	3 (5)	206- 228	2013-14

		Research				
3	A study-of performance-of the SHG bank-linkage-programmed-gujarat	Zenith International Journal of Business Economics & Management Research	2249 - 8826	3 (5)		2013-14
4	A survey of da of the month effect in world stock markets	International Journal of Management	0976 - 6502	4 (1)		2013-14
5	Behaviour of stock market price with respect to corporate event announcement in India.	Excel International Journal of Multidisciplinary Management Studies	2249 - 8834	3 (10)	37-44	2013-14
6	Factors influencing adoption of online banking among customers, an empirical study with special reference to Gujarat state.	Asian Journal of Research in Banking & Finance	2249 - 7323	3 (12)		2012-13
7	Analyzing sustainability and	ANARTA	2229 - 4376	14 (1)	147-154	2012-13

	effectiveness of SHGs: A case study of ahmedabad district.					
8	Forecasting of Indian stock market index S&P CNX NIFTY 50 using artificial neural network	ANARTA	2229 - 4376	14 (1)	1-13	2012-13
9	Consumer Satisfaction - A Comparative Study of Selected Retail Stores in India and the UK	International Management Research Academy		March 2012		2011-12
10	Indo European Linguistic: Max Muller	V-Vidyanagar	0976 - 9809	13 (2)	21-23	2011-12
11	Uncovering consumers in organised retail sector in India.	International Journal of Marketing Principles and Practice		1 (1)		2011-12
12	Uncovering consumers in Organized retail sector in india	International Jouranal of Marketing Principles and Practices		1(1)	11-16	2011-12

13	Total quality in management education institute.	VNSGU Journal of Management & Administration	0975 - 6361	1 (1)		2009-10
14	A critical study of service quality in hospitals from the patients point of view	IMED Journal of Management and Social Research		1 (1)		2008-09

Dr. N H Bhatt

No .	Title of Research Paper	Journal name	ISSN No	Volume No (Issue)	Page No	Year of Publication
1	Determinants of loyalty for private apparel: A study in organised retail store in India.	The IUP Journal Brand Management	0972 - 9097	6 (1)		2014-15
2	A study on scope of medical tourism in gujarat state: service provider's perspective.	South Asian Journal of Marketing and Management Research	2249 - 877X	4 (1)		2013-14
3	An exploratory study to precise the nature and	Pacific Business Review International	0974 - 738X	6 (1)	25-31	2013-14

	scope of medical tourism.					
4	Impact of celebrity endorser's source credibility on attitude towards advertisements and brands	South Asian Journal of Management	0971 - 5428	20 (4)		2013-14
5	Role of psychological factors in purchase behaviour with reference to private label apparels.	Asia Pacific Journal of Management Research and Innovation.	2319 - 510X	9 (2)	191- 200	2013-14
6	Private label opportunity analysis across product categories in Indian organised retail sector.	Asian Journal of Research in Business Economics and Management	2249 - 7307	2 (9)	133- 146	2012-13
7	Created Spokes – Character Credibility's Impact on Attitudes towards the Advertisement, Brand and Purchase Intentions	International Journal of Business Insight and Transformation	0974 - 5874	5 (2)		2012-13
8	Fictitious Human v/s	Journal of Marketing and	0973 -	8 (2)		2012-13

	Non – Human Created Animated Spokes – characters Endorsement: An Empirical Examination of Source Credibility and Respondent’s Age	Communication	2330			
9	Service quality measurement for retailing: benefits, needs, and implication.	South Asian Journal of Marketing and Management Research	2249 - 877X	10 (10)		2012-13
10	Retail store and service quality: a study on hypermarket in ahmedabad city.	Pacific Business Review International	0974 - 438X	6 (4)		2008-09

Dr. K L Rathod

No .	Title of Research Paper	Journal name	ISSN No	Volume No (Issue)	Page No	Year of Publication
1	A study on impulse buying behavior of college students for branded	International Journal of Management	0976 - 6510			2013-14

	apparels in Ahmadabad city.”					
2	A study on impulse buying behavior of college students for branded apparels in Ahmedabad city	International Journal of Management (IJM)	2277 - 1018	2(10)		2013-14
3	A study on key success factors of DTH service in select cities of Gujarat	RADIX - International Journal of Economics and Business Management	2277 - 1018	2(10)		2013-14
4	Retailing in India an analytical view of the sunrise industry	PARIPEX	10			2012-13
5	Impact of Retailing: In the Growth in India,	KBS	0973 - 1513		2	2010-11
6	Retailing in India: An analytic view of the sunrise Industry	International journal of Business Insights and Transformation	0974 - 5874			2010-11

7	Trends in usage of Information Technology in Organized Retailing	BMA journal of Retail & marketing issue ** National journal				2010-11
8	Brand battles - how entrenched players tackle newer, low-priced competitors	Multidisciplinary issue research and studies	0976 - 4712			2008-09
9	“Indian Ratailint and Retail Formats in India”.	International Journal of Management. Jaipur.		Vol. I		2008-09
10	“ORPAT Industries: A Case Study”	ICFAI Journal of Management		Vol. 8(1)	P. 48-55	2008-09

Dr. A. G Modi

N o.	Title of Research Paper	Journal name	ISSN No	Volume No (Issue)	Page No	Year of Publication	Impact Factor
1	A Survey of Day of the Month Effect in	International Journal of Management (IJM)	ISSN 0976-6502	Volume 4	221 - 234	2012-13	6.91

	World Stock Markets						
2	A Study of Indian Banks with Reference to Service Quality Attributes and Customer Satisfaction	International Journal of Research in Computer Application and Management, [IJRCM]	ISSN 2231-1009	Volume 2, Issue. 5	103 - 107	2012-13	5.09
3	Acceptance of Internet Banking among Retail Customers ; Survey Evidence from Ahmedabad Region	The IUP Journal of Bank Management (IJBm)	ISSN 0972-6918	Volume XII, Number 1	63-71	2012-13	2.01
4	To Study the working conditions Level in Rajasthan Healthcare	International Journal of Scientific Research [IJSR]	ISSN 2277-8179	Volume 1, Issue 1	49-51	2012-13	0.33
5	Credit Life Insurance for Home loan	Credit Life Insurance for Home loan Customers in	ISSN 2230-7830	Volume 2, Issue 11		2012-13	0.21

	Customers in India	India					
6	Effect of Internet Based Banking Services on Service Quality of Indian Banks: An Empirical Investigation	Asian Journal of Research in Banking and Finance [AJRBF]	ISSN 2249-7323	Volume Number 2, Issue 9	41-58	2012-13	
7	Environmental Clearance: Daunting Challenge & Mystifying Signal To Stakeholders Of India	International Journal Of Social Science & Interdisciplinary Research, (IJSSIR)	ISSN 2277-3630	Volume 1, Number 4	156 - 164	2012-13	
8	Forest Management Systems and Community-Based Forestry: A Case of Sabarkantha (South) Forest Division of Gujarat	Social Science Research Network (SSRN)	Working Paper Series	Online		2012-13	

	state						
9	Non-Timber Forest Products in Sustainable Forest Management	Social Science Research Network (SSRN)	Working Paper Series	Online Journal		2012-13	
10	Public Healthcare Delivery System: Contemporary HR Policies and Success	Pacific Business Review International	ISSN 0974-438X	Volume 5, Issue 5	101 - 108	2012-13	
11	A Study of Staffing Pattern in Rajasthan Public Healthcare Delivery System	International Index Journal- Indian Journal of Applied Research, [India]	ISSN 2249-555X	Volume 1, Issue 5	101 - 104	2011-12	0.82
12	An Emerging Role and Need of Risk Management for Indian Hospitals	Proficient International Refereed Journal of Management	ISSN 0975-847X	Volume II, Issue 1		2011-12	
13	Decoding Black	Risk Management	Working	Volume 4,		2011-12	

	Swan: A Quantitative Approach To Tactical Stock Investing	eJournal, Social Science Research Network (SSRN)	Paper Series	Issue 3			
14	Finding the Identical Twin	Multiple Equation Models eJournal, Social Science Research Network (SSRN),	Working Paper Series	Volume 5, Number 1		2011-12	
15	Right To Sight: A Management Case Study on Arvind Eye Hospitals	International Journal Of Multidisciplinary Research [ZIJMR]	ISSN 2231-5780	Volume 2, Issue 1	447 - 457	2011-12	
16	The Study on Co-Movement of Selected Stock Markets	International Research Journal of Finance and Economics, Eurojournal	ISSN 1450-2887	Issue 47	164 - 179	2011-12	
17	Employees' Brand Commitment and Career Stages:	The IUP Journal of Brand Management, [India]	ISSN 0972-9097	Volume IX, Number 1	28-39	2008-09	2.01

	Empirical Evidence from Indian Universities						
--	---	--	--	--	--	--	--

Dr. K K Patel

No .	Title of Research Paper	Journal name	ISSN No	Volume No (Issue)	Page No	Year of Publication
1	“A Study on Impact of Organized Retailer on Unorganized Retailer”	International Journal of Research in Management, Economics and Commerce.	2250-0575 X	2(5)	64	2012-13
2	“Impact of Service Quality on Customer Loyalty In Private & Public Sector Banks”	PROTSAHAN	2321-869	SEPT-2013	376	2012-13
3	“Innovations in Indian Banking Services: Emerging Trends, Issues & Challenges”	ANARTA-	2229-4376	14(1)	69	2012-13
4	Developmen	Jouranl of	2231-		112	2011-12

	t of credit rating Model for Bank loan Rating	Research, Commerce,IT and Management	5756			
--	---	--------------------------------------	------	--	--	--

- Monographs **Nil**
- Chapters in Books **Nil**
- Edited Books **Nil**
- Books with ISBN with details of publishers

Dr. B A Prajapati

No	Title of Book and Book Chapter	ISBN No	Name of Publisher	Year
1	Gyanshakti - Manasna Vavetar No Mahayagna	978-93-5070-023-5	Shanti Prakashan	2012-13
2	Saraswati Koumudi	978-93-82869-35-1	Parsh Publication	2012-13
3	Dipe Aruna Prabhat	978-81-921045-1-5	VNSG university	2011-12
4	Dipe Arunu Prabhat	978-81-921045-1-5	V.N. S.G. University	2011-12
5	Study of Impact of Quality Management Practices in Service Companies	978-3-8443-2836-3	Lambert Academic Publishing Germany	2011-12
6	Competitive advantage of Outsourcing on Indian IT & IT enabled service industry: a strategic perspective of Indian service sector.	0230-63469-9 978-0230-63469-5	Macmillan Advance Research Services, Macmillan India Ltd.	2008-09

- Number listed in International Database (For *e.g.* Web of Science, Scopus,
- Humanities International Complete, Dare Database - International Social Sciences Directory, EBSCO host, etc.) **Nil**
- Citation Index – range / average **Nil**
- SNIP **Nil**
- SJR **Nil**
- Impact Factor – range / average **Nil**
- h-index **Nil**

23. Details of patents and income generated
Nil

24. Areas of consultancy and income generated

A study on Consumer Satisfaction from Healthcare organizations : Promoting Healthcare Consumerism at Gujarat	Dr. Ashwin Modi	Ministry of Consumer Affairs, New Delhi	Rs.379000/-
--	-----------------	---	-------------

25. Faculty selected nationally / internationally to visit other laboratories / institutions

/ industries in India and abroad

- Dr. A G Modi, got prestigious Raman Fellowship (Post Doctoral) under Indo-US bilateral cooperation.

26. Faculty serving in

- a) National committees b) International committees c) Editorial Boards d) any other (please specify)

National Committee

Dr B A Prajapati as NAAC peer team member and also as NAAC Peer

Team Chairman

Editorial Boards

Dr. B.A.Prajapati : “ANART” – University Research Publication

Dr. N.H. Bhatt : “ANART” – University Research Publication

Dr. A.G. Modi : “ANART” – University Research Publication

27. Faculty recharging strategies (UGC, ASC, Refresher / orientation programs, workshops, training programs and similar programs).

Nil

28. Student projects

- percentage of students who have done in-house projects including inter-departmental projects
100% All students are given Research Project in Sem- III & IV in MBA Programme
- percentage of students doing projects in collaboration with other universities

/ industry / institute

100%, Summer Internship with Industry For MBA Students.

29. Awards / recognitions received at the national and international level by

- Faculty **Nil**
- Doctoral / post doctoral fellows --
- Students --

30. Seminars/ Conferences/Workshops organized and the source of funding (national

/ international) with details of outstanding participants, if any.

The department has organized one International conference on Relative Economics in 2011-12 (More than 300 participants participated) and One National Conference on Financial Aspects in 2010-11 funded by UGC. (Approx 200 participants participated).

31. Code of ethics for research followed by the departments
As per university norms

32. Student profile programme-wise:

Name of the Programme (refer to question no. 4)	Applications received	Selected		Pass percentage	
		Male	Female	Male	Female
MBA	60	40	20	100%	100%
M.Com	59	32	27	100%	100%
M.Phil (Commerce)	20	12	8	100%	100%

33. Diversity of students

Name of the Programme (refer to question no. 4)	% of students from the same university	% of students from other universities within the State	% of students from universities outside the State	% of students from other countries
MBA	90%	10%	0%	0%
M.Com	93%	5%	2%	0%
M.Phil (Commerce)	100%	0%	0%	0%

34. How many students have cleared Civil Services and Defense Services examinations, NET, SET, GATE and other competitive examinations? Give details category-wise.

Nil

35. Student progression

Student progression	Percentage against enrolled
UG to PG	NA
PG to M.Phil.	0%
PG to Ph.D.	0%
Ph.D. to Post-Doctoral	0%
Employed	
<input type="checkbox"/> Campus selection	15%
<input type="checkbox"/> Other than campus recruitment	85%
Entrepreneurs	0%

36. Diversity of staff

Percentage of faculty who are graduates	
of the same university	02
from other universities within the State	03
from universities from other States	00
from universities outside the country	00

37. Number of faculty who were awarded M.Phil., Ph.D., D.Sc. and D.Litt. during the assessment period

02 faculty members

38. Present details of departmental infrastructural facilities with regard to

a) Library - Yes

b) Internet facilities for staff and students Yes

c) Total number of class rooms 04

d) Class rooms with ICT facility 04

e) Students' laboratories 02 (Computer Labs)

39. List of doctoral, post-doctoral students and Research Associates

a) from the host institution/university

b) from other institutions/universities

40. Number of post graduate students getting financial assistance from the university.

Nil

41. Was any need assessment exercise undertaken before the development of new programme(s)? If so, highlight the methodology.

42. Does the department obtain feedback from

a. faculty on curriculum as well as teaching-learning-evaluation? If

yes, how does the department utilize the feedback?

Yes, Informal method of feedback. Suggestion are discussed in BoS and then incorporated in modified syllabus.

b. students on staff, curriculum and teaching-learning-evaluation and how does the department utilize the feedback?

Yes, Informal method of feedback. Suggestion are discussed in staff meeting and accordingly action is being taken.

c. alumni and employers on the programmes offered and how does the department utilize the feedback?

Yes, Informal method of feedback. Suggestion are discussed in staff meeting and accordingly action is being taken.

43. List the distinguished alumni of the department (maximum 10)

1. Jatin S Pancholi – Associate Professr, Middle sex University, UK (1996-1998 Batch)
2. Paurav Shukla - Associate Professr, Brighton University, UK (1996-1998 Batch)
3. Nilesh Thakkar - South East Asian Head, UBS Bank, Switzerland (1997-1999 Batch)
4. Shivani Raval – Director Finance, Rachna International, Ahmedabad (2005-07)
5. Mahendra Sharma - Director, Management Programme and Pro- VC Ganpat University, Mehsana. (1997-1999 Batch)
6. Komal Kanzaria – Vice President, MCX, Mumbai (1996-1998 Batch)
7. Bhavin Pandya – Director, SVIM, KSV University, Gandhinagar (2001-2003 Batch)
8. Ankita Parmar – Dy. Collector, Gov. of Gujarat (1996-1998 Batch)
9. Samveg Patel – Assistant Professor, Goa Institute of Management, Goa (2005-2007 Batch)
10. Ritesh Dalwadi – Professor, Humber College , CANADA (2003-2005 Batch)

44. Give details of student enrichment programmes (special lectures / workshops / seminar) involving external experts.

Experiential learning, add-on courses, live projects, involving the students in the various co-curricular and extra –curricular activities

45. List the teaching methods adopted by the faculty for different programmes.

- Structured Lectures
- Seminars
- Case studies

- Hands-on Training
 - Project Assignment
 - Role Playing
 - Business Games
 - Industrial Visits
 - Guest Lectures
 - Panel Discussions
46. How does the department ensure that programme objectives are constantly met and learning outcomes are monitored?
With the help of continuous evaluation and placement of the students. Also from feedbacks received from corporate recruiters and alumni network.
47. Highlight the participation of students and faculty in extension activities. Faculty encourages students to participate and hold several co-curricular and extracurricular activities.
48. Give details of “beyond syllabus scholarly activities” of the department.
- Seminar/Conference /Work shop
 - Business Plan Competitions
 - Brain Storming Sessions
49. State whether the programme/ department is accredited/ graded by other agencies? If yes, give details.
NO
50. Briefly highlight the contributions of the department in generating new knowledge, basic or applied.
Live project and summer internship helps students to acquire the practical aspect of study. – Management Research Projects are also given to students on industry analysis and current issues of industries.
51. Detail five major Strengths, Weaknesses, Opportunities and Challenges (SWOC) of the department.
- Strengths:**
- Core faculty – all having doctorate degree and good academic & rich industry experience
 - Research Work
 - Good industry orientation and placement.
- Weaknesses:**
- Location disadvantage
 - Limited autonomy
 - High degree of centralization

- Non proximity to industrial hubs
- Resource constraints.

Opportunities:

- Corporate Training & Research
- Knowledge Portal & Institutional Networking
- National /International Institutions Collaborations

Challenges:

- Competitive environment
- Setting up State of the Art Educational Infrastructure to combat the challenges from private Institutions.
- Sustenance of placement against economic slow down
- Attracting best students and Faculty.

52. Future plans of the department.
Increasing the faculty strength and reduction of student-teacher ratio from 15:1 to half.
Focus on Research and consultancy.

Evaluative Report of the Department of English

1. Name of the Department
Department of English
2. Year of establishment
1993
3. Is the Department part of a School/Faculty of the university?
Faculty of the university
4. Names of programmes offered (UG, PG, M.Phil., Ph.D., Integrated Masters; Integrated Ph.D., D.Sc., D.Litt., etc.)
PG, M.Phil, Ph.D.
5. Interdisciplinary programmes and departments involved
Centre for Indian Diaspora & Cultural Studies
6. Courses in collaboration with other universities, industries, foreign institutions, etc.
-No-
7. Details of programmes discontinued, if any, with reasons
-No-
8. Examination System: Annual/Semester/Trimester/Choice Based Credit System
Choice Based Credit System
9. Participation of the department in the courses offered by other departments
-No-
10. Number of teaching posts sanctioned, filled and actual (Professors/Associate Professors/Asst. Professors/others)

	Sanctioned	Filled	Actual (including CAS & MPS)
Professor	01	00	01
Associate Professors	02	01	01
Asst. Professors	02	02	02
Others – Teaching Assistants	03	03	03

11. Faculty profile with name, qualification, designation, area of specialization, experience and research under guidance

Name	Qualification	Designation	Specialization	No. of Years of Experience	No. of Ph.D./M.Phil. students guided for the last 4 years
Dr. Adesh Pal	M.A.,M.Phil., Ph.D.	Prof &Head	Diasporic Studies, Colonial and Post Colonial Studies, Philosophy and Literature, History and Literature	25	Ph.D. – 08 M.Phil – 12
Dr. Tapas Chakrabarti	M.A. ,Ph.D.	Asso. Professors	Diasporic Studies, Colonial and Post Colonial Studies, Phiolosophy and Literature, History and Literature	19	Ph.D. – 10 M.Phil – 15
Dr. Hetal S. Patal	M.A.,Ph.D.	Asst.Professors	Diasporic Studies, Colonial and Post Colonial Studies, Phiolosophy and Literature, History and Literature	09	Ph.D. – 00 M.Phil – 10

12. List of senior Visiting Fellows, adjunct faculty, emeritus professors

13. Percentage of classes taken by temporary faculty – programme-wise information
-M.A.-

14. Programme-wise Student Teacher Ratio

M.A.,& M.Phil 3:59

15. Number of academic support staff (technical) and administrative staff: sanctioned, filled and actual:

	Sanctioned	Filled	Actual
Technical-	01	01	01
Administrative-	01	01	01
Peon-	01	01	01

16. Research thrust areas as recognized by major funding agencies:
Diaspora Studies, Cultural Studies

17. Number of faculty with ongoing projects from a) national b) international funding agencies and c) Total grants received. Give the names of the funding agencies, project title and grants received project-wise.
-No-

18. Inter-institutional collaborative projects and associated grants received
a) National collaboration b) International collaboration

No.	Title of Research Project▲	Name of PI	Funding Agency	Amount mobilized	Project Type category
1	Centre for Indian Diaspora and Cultural Studies	Dr. Adesh Pal	UGC, New Delhi under Area Study Center	400000	A
2	Preparation of Database of Migrants from Gujarat	Dr. Adesh Pal	UGC		A
3	Vatan Seva : NRG's Contribution of Gujarat	Dr. Adesh Pal	UGC, New Delhi under Area Study Center		A

19. Departmental projects funded by DST-FIST; UGC-SAP/CAS, DPE; DBT, ICSSR, AICTE, etc.; total grants received.
-No-

20. Research facility / centre with
• state recognition – Yes -

- national recognition – Yes -
 - international recognition – Yes -
21. Special research laboratories sponsored by / created by industry or corporate bodies -No-
22. Publications:
- * Number of papers published in peer reviewed journals (national / international)
 - * Monographs
 - * Chapters in Books
 - * Edited Books
 - * Books with ISBN with details of publishers

Dr. Adesh Pal

No	Title of Book and Book Chapter	ISBN No	Name of Publisher	Year
1	Global Gujarat and its Diaspora	ISBN 81-8043-084-7	Creative Books, New Delhi	2011-12

- * Number listed in International Database (For e.g. Web of Science, Scopus, Humanities International Complete, Dare Database - International Social Sciences Directory, EBSCO host, etc.)
 - * Citation Index – range / average
 - * SNIP
 - * SJR
 - * Impact Factor – range / average
 - * h-index
23. Details of patents and income generated
-NA-
24. Areas of consultancy and income generated
-NA-
25. Faculty selected nationally / internationally to visit other laboratories / institutions / industries in India and abroad
-Nil-
26. Faculty serving in
- a) National committees
 - b) International committees
 - c) Editorial Boards
 - d) any other (please specify)
- Dr. Adesh Pal

27. Faculty recharging strategies (UGC, ASC, Refresher / orientation programs, workshops, training programs and similar programs).
The Department encourages faculty members to organized and attend international seminars, Symposium. The Department also encourages faculty members to attend UGC sponsored refresher / orientation course.
28. Student projects
-Nil-
- percentage of students who have done in-house projects including inter-departmental projects
 - percentage of students doing projects in collaboration with other universities / industry / institute
29. Awards / recognitions received at the national and international level by
- Faculty -00-
 - Doctoral / post doctoral fellows -00-
 - Students -00-
30. Seminars/ Conferences/Workshops organized and the source of funding (national / international) with details of outstanding participants, if any.
International Seminar- 02 / Workshop-01
31. Code of ethics for research followed by the departments
-NA-
32. Student profile programme-wise:

Name of the Programme (refer to question no. 4)	Applications received	Selected		Pass percentage	
		Male	Female	Male	Female
M.A.– 2009-10	52	13	20	100 %	100 %
M.A. - 2010-11	33	07	10	100 %	100 %
M.A. - 2011-12	42	10	14	100 %	100 %
M.A. - 2012-13	48	14	15	100 %	100 %
M.A. - 2013-14	53	08	18		
M.PHIL- 2009-10	26	07	05	100 %	100 %
M.PHIL- 2010-11	-	-	-	-	-
M.PHIL- 2011-12	-	-	-	-	-
M.PHIL- 2012-13	20	09	11	100 %	100 %
M.PHIL- 2013-14	36	13	07		

33. Diversity of students

Name of the Programme (refer to question no. 4)	% of students from the same university	% of students from other universities within the State	% of students from universities outside the State	% of students from other countries
M.A. 2009-10 to 2013-14	104	25	00	00
M.PHIL 2009-10 to 2013-14	49	03	00	00

34. How many students have cleared Civil Services and Defence Services examinations, NET, SET, GATE and other competitive examinations? Give details category-wise.

01-Male- SC

35. Student progression

Student progression	Percentage against enrolled
UG to PG	NA
PG to M.Phil.	20%
PG to Ph.D.	05%
Ph.D. to Post-Doctoral	00
Employed	
<ul style="list-style-type: none"> • Campus selection • Other than campus recruitment 	
Entrepreneurs	

36. Diversity of staff

Percentage of faculty who are graduates	
of the same university	80%
from other universities within the State	00%
from universities from other States	20%
from universities outside the country	00%

37. Number of faculty who were awarded M.Phil., Ph.D., D.Sc. and D.Litt. during the assessment period

-01-

38. Present details of departmental infrastructural facilities with regard to

a) Library –Yes-

b) Internet facilities for staff and students –Yes-

- c) Total number of class rooms -03-
- d) Class rooms with ICT facility -01-
- e) Students' laboratories -00-
- f) Research laboratories -00-

39. List of doctoral, post-doctoral students and Research Associates

a) from the host institution/university -07-

Sr.	Name	Year	University	Guide name
1.	Patel Hetal Shankarbhai	2009	H.N.G.U.	Dr. Adesh pal
2.	Rathod Jasvantkumar V.	2012	H.N.G.U.	Dr. Adesh Pal
3.	Rajput Hetal G.	2012	H.N.G.U.	Dr. Adesh Pal
4.	Damor Minal G.	2012	H.N.G.U.	Dr. Adesh Pal
5.	Pandya Chiragkumar S.	2011	H.N.G.U.	Dr. Tapas Chakrabarti
6.	Prajapati Anjana D.	2012	H.N.G.U..	Dr. Tapas Chakrabarti
7.	Darji Pushpak P.	2012	H.N.G.U.	Dr. Tapas Chakrabarti

b) from other institutions/universities – 15-

Sr.	Name	Year	University	Guide name
1.	Pandit Ujjaval Damodaray	2008	other	Dr. Adesh pal
2.	Patel Hitesh P.	2010	other	Dr. Adesh Pal
3.	Bhatt Divesh D.	2010	other	Dr. Adesh Pal
4.	Vankar Gopalbhai V.	2010	other	Dr. Adesh Pal
5.	Patel Vishnu Ishawarbhai	2011	other	Dr. Adesh Pal
6.	Parekh Keyur K.	2009	other	Dr. Tapas Chakrabarti
7.	Usha Kaushik V.	2010	other	Dr. Tapas Chakrabarti
8.	Joshi Dipam J.	2010	other	Dr. Tapas Chakrabarti
9.	Dhoriya Yagnesh N.	2010	other	Dr. Tapas Chakrabarti
10.	Vidya Yatharth N.	2010	other	Dr. Tapas Chakrabarti
11.	Sutaria Amitkumar N.	2011	other	Dr. Tapas Chakrabarti
12.	Thakkar Gaurav S.	2012	other	Dr. Tapas Chakrabarti
13.	Kamol Hariprasad N.	2012	other	Dr. Tapas Chakrabarti
14.	Prajapati Hetal G.	2012	other	Dr. Tapas Chakrabarti
15.	Patel Kanubhai D.	2012	other	Dr. Tapas Chakrabarti

40. Number of post graduate students getting financial assistance from the university.

Name of the Programme (refer to question no. 4)	S.C	S.T.	OBC	Minority
M.A. 2009-10 to 2013-	22	14	58	01

Name of the Programme (refer to question no. 4)	S.C	S.T.	OBC	Minority
14				
M.PHIL 2009-10 to 2013-14	03	01	07	00

41. Was any need assessment exercise undertaken before the development of new programme(s)? If so, highlight the methodology.
-No-

42. Does the department obtain feedback from
a. faculty on curriculum as well as teaching-learning-evaluation? If yes, how does the department utilize the feedback? -Yes-
b. students on staff, curriculum and teaching-learning-evaluation and how does the department utilize the feedback? -No-
c. alumni and employers on the programmes offered and how does the department utilize the feedback? -No-

43. List the distinguished alumni of the department (maximum 10)
-NA-

44. Give details of student enrichment programmes (special lectures / workshops / seminar) involving external experts.

Special Lectures List

Year 2008-09

1. Dr. Piyush S Joshi - V.V. Nagar Anand
2. Dr. M.F. Salat - Deptt. of Eng. Faculty of Arts, M.S. Uni.Vadodara
3. Dr. Mukunbhai L Revadiwala - Mahila College Unjha
4. Dr. Nanda M. Jadeja - Smt A.S.C. Mahila Arts & Home Science College, Mehsana

Year 2009-10

1. Dr. Mukunbhai L Revadiwala - Mahila College Unjha
2. Dr. Premnath Mishra - M.N. Science College, Patan

Year 2010-12

1. Dr. Kamal Mehta - Prof. & Head (Deptt. Eng) Saurashtra University, Rajkot.
2. Dr. Jaydeepsinh Dodiya - Reader, (Deptt. Eng) Saurashtra University, Rajkot.

- | | | |
|-----------------------|---|--|
| 3. Dr. Seema Malik | - | Prof. (Deptt. Eng) M.S. Uni. Udaipur |
| 4. Dr. Santosh Sukala | - | Prof. J. N. Uni. Delhi |
| 5. Dr. Kapil Kapoor | - | Prof. of Eng & P.V.C. J. N. Uni. Delhi |
| 6. Dr. Dhananjaysinh | - | Reader, Deptt. of Eng J. N. Uni. Delhi |

Year 2013-14

1. Dr. Pradeep Prajapati - Deptt. of Eco. Gujarat Uni. Ahmedabad
 2. Dr. Jaydeepsinh Dodiya - Reader, (Deptt. Eng) Saurashtra University, Rajkot.
45. List the teaching methods adopted by the faculty for different programmes.
Group Discussion
Debate
Seminars
PowerPoint Presentation
 46. How does the department ensure that programme objectives are constantly met and learning outcomes are monitored?
The Department has adopted continuous evaluation in order to monitor the achievement of learners.
 47. Highlight the participation of students and faculty in extension activities.
 48. Give details of “beyond syllabus scholarly activities” of the department.
 49. State whether the programme/ department is accredited/ graded by other agencies? If yes, give details.
-No-
 50. Briefly highlight the contributions of the department in generating new knowledge, basic or applied.
-No-
 51. Detail five major Strengths, Weaknesses, Opportunities and Challenges (SWOC) of the department.
* Strength:-
 1. The Faculty members are actively engaged in multi disciplinary research.
 2. Being situated in a geographically disadvantaged area, students have a great sense of desire for learning.
 3. The faculty consists of teachers who have proven administrative abilities at the highest level.
 4. A Cosmopolitan multi lingual faculty drawn from different areas of the country.

5. A Comparatively young and energetic faculty with vibrant and innovative ideas.

* Weaknesses:-

1. Lack of linguistic competence among student.
2. Lack of awareness among the guardians/ parents of the students regarding higher research and the rewards brought by research.

52. Future plans of the department.
Focusing on quality education and research.

Evaluative Report of the UGC Area Study Centre for Indian Diaspora and Cultural Studies

1. Name of the Department : UGC Area Study Centre for Indian Diaspora and Cultural Studies
2. Year of establishment :2003
3. Is the Department part of a School/Faculty of the university? : Faculty of the University
4. Names of programmes offered (UG, PG, M.Phil., Ph.D., Integrated Masters; Integrated Ph.D., D.Sc., D.Litt., etc.) : M.Phil., Ph.D.
5. Interdisciplinary programmes and departments involved : No
6. Courses in collaboration with other universities, industries, foreign institutions, etc.: No
7. Details of programmes discontinued, if any, with reasons : No
8. Examination System: Annual/Semester/Trimester/Choice Based Credit System : Choice Based Credit System
9. Participation of the department in the courses offered by other departments: No
10. Number of teaching posts sanctioned, filled and actual (Professors/Associate Professors/Asst. Professors/others)

	Sanctioned	Filled	Actual (including CAS and MPS)
Professor	-	-	-
Associate Professor	01	00	00
Assistant Professor	01	00	00
Other(Guest Faculty)	02	01	01

11. Faculty profile with name, qualification, designation, area of specialization, experience and research under guidance

Name	Qualification	Designation	Specialization	No. of Years of Experience	No. of Ph.D./ M.Phil. students guided for the last 4 years
1 Rameshbhai Chaudhari	M.A., M.Phil, Ph.D	Research Associate	Hindi Literature, Poetry	10	Nil

12. List of senior Visiting Fellows, adjunct faculty, emeritus professors :
13. Percentage of classes taken by temporary faculty – programme-wise information
14. Programme-wise Student Teacher Ratio
15. Number of academic support staff (technical) and administrative staff: sanctioned, filled and actual

	Sanctioned	Filled	Actual
Technical-	01	00	00
Administrative-	01	00	00
Peon-	01	01	01

16. Research thrust areas as recognized by major funding agencies: Organization of International Conferences, Conducting Database of Migrants from entire Gujarat, Field Trip outside India for further details of migrants, Book Publication
17. Number of faculty with ongoing projects from a) national b) international funding agencies and c) Total grants received. Give the names of the funding agencies, project title and grants received project-wise.
- 1). Number of faculty: 01
 - 2). National
 - 3) Total grants received: 25, 00, 000
 - 4) Names of the funding Agency: University Grants Commission

- h-index
23. Details of patents and income generated : Nil
 24. Areas of consultancy and income generated : N.A.
 25. Faculty selected nationally / internationally to visit other laboratories / institutions
/ industries in India and abroad : 01
 26. Faculty serving in

National committees b) International committees c) Editorial Boards
d) any other (please specify) : 01, Dr. Adesh Pal
 27. Faculty recharging strategies (UGC, ASC, Refresher / orientation programs, workshops, training programs and similar programs). N.A.
 28. Student projects : Nil
 - percentage of students who have done in-house projects including inter-departmental projects :
 - percentage of students doing projects in collaboration with other universities
/ industry / institute
 29. Awards / recognitions received at the national and international level by
 - Faculty - 00
 - Doctoral / post doctoral fellows -00
 - Students- 00
 30. Seminars/ Conferences/Workshops organized and the source of funding (national / international) with details of outstanding participants, if any.
International Conferences: 05, Funded by UGC and State Government
Workshop: 01, Funded by UGC
 31. Code of ethics for research followed by the departments
 32. Student profile programme-wise:

Name of the Programme	Applications received	Selected		Pass percentage	
		Male	Female	Male	Female
M.Phil(2013-14)	10	05	05		

33. Diversity of students

Name of the Programme (refer to question no. 4)	% of students from the same university	% of students from other universities within the State	% of students from universities outside the State	% of students from other countries
M.Phil(2013-14)	70%	30%	00	00

34. How many students have cleared Civil Services and Defense Services examinations, NET, SET, GATE and other competitive examinations? Give details category-wise.

None

35. Student progression

Student progression	Percentage against enrolled
UG to PG	
PG to M.Phil.	
PG to Ph.D.	01
Ph.D. to Post-Doctoral	
Employed <input type="checkbox"/> Campus selection <input type="checkbox"/> Other than campus recruitment	
Entrepreneurs	

40. List the distinguished alumni of the department (maximum 10)
41. Give details of student enrichment programmes (special lectures / workshops / seminar) involving external experts.
Special Lectures List

Year 2008-09

1. Dr. Piyush S Joshi - V.V. Nagar Anand
2. Dr. M.F. Salat - Deptt. of Eng. Faculty of Arts, M.S. Uni.Vadodara
3. Dr. Mukunbhai L Revadiwala - Mahila College Unjha
4. Dr. Nanda M. Jadeja - Smt A.S.C. Mahila Arts & Home
Science
College, Mehsana

Year 2009-10

1. Dr. Mukunbhai L Revadiwala - Mahila College Unjha
2. Dr. Premnath Mishra - M.N. Science College, Patan

Year 2013-14

1. Dr. Pradeep Prajapati - Deptt. of Eco. Gujarat Uni. Ahmedabad
 2. Dr. Jaydeepsinh Dodiya - Reader, (Deptt. Eng) Saurashtra
University, Rajkot.
42. List the teaching methods adopted by the faculty for different programmes.
Group Discussion
Debate
Seminars
PowerPoint Presentation
 43. How does the department ensure that programme objectives are constantly met and learning outcomes are monitored?
Centre has adopted continuous evaluation in order to monitor the achievement of learners
 44. Highlight the participation of students and faculty in extension activities.
 48. Give details of “beyond syllabus scholarly activities” of the department.

49. State whether the programme/ department is accredited/ graded by other agencies? If yes, give details.

No

50. Briefly highlight the contributions of the department in generating new knowledge, basic or applied.

51. Detail five major Strengths, Weaknesses, Opportunities and Challenges (SWOC) of the department.

* Strength:-

1. The Faculty members are actively engaged in multi disciplinary research.
2. Being situated in a geographically disadvantaged area, students have a great sense of desire for learning.
3. The faculty consists of teachers who have proven administrative abilities at the highest level.
4. A Cosmopolitan multi lingual faculty drawn from different areas of the country.
5. A Comparatively young and energetic faculty with vibrant and innovative ideas.

* Weaknesses:-

1. Lack of linguistic competence among student.
2. Lack of awareness among the guardians/ parents of the students regarding higher research and the rewards brought by research

52. Future plans of the department.

Focusing on research.

Evaluative Report of The Department Of Hospital Management

1. Name of the Department :
DEPARTMENT OF HOSPITAL MANAGEMENT
2. Year of establishment : 2009
3. Is the Department part of a School/Faculty of the university: Yes
4. Names of programmes offered (UG, PG, M.Phil., Ph.D., Integrated Masters; Integrated Ph.D., D.Sc., D.Litt., etc.):
MASTER OF HOSPITAL MANAGEMENT (MHM)
POST-GRADUATE DIPLOMA IN HOSPITAL MANAGEMENT (PGDHM)
5. Interdisciplinary programmes and departments involved
Not Applicable
6. Courses in collaboration with other universities, industries, foreign institutions, etc. – Not Available --
7. Details of programmer discontinued, if any, with reasons : None
8. Examination System: Annual/Semester/Trimester/Choice Based Credit System: Semester exam in CBCS system
9. Participation of the department in the courses offered by other departments
Not Applicable
10. Number of teaching posts sanctioned, filled and actual (Professors/Associate Professors/Asst. Professors/others)

	Sanctioned	Filled	Actual (including CAS & MPS)
Director	01	00	00
Professor	02	00	00
Associate Professors	03	01	01
Asst. Professors	05	02	02
Others (Medical Officer)	01	01	01

11. Faculty profile with name, qualification, designation, area of specialization, experience and research under guidance

Name	Qualification	Designation	Specialization	No. of Years of Experience	No. of Ph.D./M.Phil. students guided for the last 4 years
Dr. K. K. Patel	Ph. D. (Management) MBA (Financial Management) LL. B. B. B. A.	Associate Professor	Management	10 Years 10 Months	M. Phil: 19-Students Guided Ph. D. 4- Students Registered
Dr. Bhupinder Chaudhary	Ph.D. (Hospital Management), M.B.A. (Hospital Management), B.A.M.S.	Assistant Professor	Hospital Management	6 Years, 8 months	-
Mr. Nimesh Bhojak	Ph.D. (pursuing), UGC-NET, M.B.A., B.B.A.	Assistant Professor	Financial Management	5 years	-
Dr. Vipin Soni	M.S. (Ortho), MBBS	Medical Officer	Orthopedic Surgery	5 Years	-

12. List of senior Visiting Fellows, adjunct faculty, emeritus professors

- Dr. Sharad Vyas, Director Emergency Services, Office of Health Commissioner, Gandhinagar
- Dr. Anil Jain, MS , Mch (CVT), Krishna Hospital , Ahmedabad
- Dr. Mukesh Shah, MS , Rajasthan Hospital , Ahmedabad
- Dr. Rasanand Panda, Associate Professor, IIPM, Gandhinagar
- Prof. M. M. Prabhakar, HOD, Ortho Department, Civil & Director of paraplegia hospital, Ahmedabad
- Dr. Mahendra Sharma, Dean & Director, Faculty of Management Studies, Ganpat University, Kherva
- Prof. Vinod Laheri, Head, Orthopedic Department, G. S. Medical College, Bombay
- Prof. P.S.Ramani, MS , Lilavati Hospital , Mumbai

- Ms. Shikha Sharda, Business Promotion, Centre for Sight Hospital, New Delhi
- Mr. Somnath Chattopadhyaya, Consultant, Medica Synergie
- Dr. Pankaj Dhamija, Medical Superintendent, Fortis Hospital, Noida
- Mr. Suhas Aradhaye, MD, Sree Garga Consultancy, Mumbai
- Dr. Bidhan Das, MD, Octavo Solutions, New Delhi
- Mr. Jatin Kumar, Assistant Director- NABH, QCI, New Delhi
- Ms. Khushbhu Sewariya, Executive - SCM, Artemis Health Institute, Gurgaon
- Mr. Jeckson, Marketing Manager, Apollo International Hospital, Gandhinagar
- Dr. Nikhil Tiwari, Medical Superintendent, Jaypee Hospital, New Delhi
- Dr. Manshukh R. Kanani, President, Gujarat State Board, Indian Medical Association
- Dr. K. Vishwanath, Administrator, Apollo Hospital, Hyderabad.
- Dr. P. Mamtha, Administrator, Care Hospital, Hyderabad.
- Mr. Ghanshyam, Marketing Manager, Global Hospital & Research Centre, Mount Abu, Rajasthan

13. Percentage of classes taken by temporary faculty – programme-wise information:

Master of Hospital Management:

10%

Post-Graduate Diploma in Hospital Management: 70%

14. Programme-wise Student Teacher Ratio:

MHM Programme: 23: 1

15. Number of academic support staff (technical) and administrative staff: sanctioned, filled and actual:

Clerk: 01

Technical Assistant: 01

Peon: 02

Librarian: 01

16. Research thrust areas as recognized by major funding agencies: N/A

17. Number of faculty with ongoing projects from a) national b) international funding agencies and c) Total grants received. Give the names of the funding agencies, project title and grants received project-wise.

- Ongoing Projects: 1 (Dr. Ashwin G Modi & Dr. Bhupinder Chaudhary)
- Funding Agencies: I.I.P.A.- New Delhi,
- Total Grants: Rs. 3.79 lakhs

- Title: Consumer Satisfaction from healthcare organization promoting healthcare consumerism in Gujarat: A study.
- June 2013 to June 2015

18. Inter-institutional collaborative projects and associated grants received: N/A

a) National collaboration b) International collaboration

19. Departmental projects funded by DST-FIST; UGC-SAP/CAS, DPE; DBT, ICSSR, AICTE, etc.; total grants received. NA

20. Research facility / centre with

- state recognition: NIL
- national recognition: NIL
- international recognition: NIL

21. Special research laboratories sponsored by / created by industry or corporate bodies: N/A

22. Publications:

* Number of papers published in peer reviewed journals (national / international) : 18

International Journal:

Sr .	Title of Paper	Name of Journal	ISSN No.	Volume	Page No:	Impact Factor.	Author
1.	Causes of low utilization of Primary level of Healthcare services in North Gujarat	Pacific Business Review International	0974 - 438X	Volume 7, Issue 2, August 2014	38-44	NA	Dr. Bhupinder Chaudhary
2.	Revamping policies and strategies of public health management in India: a	Pacific Business Review International	0974 - 438X	Volume 5, Issue 7, January 2013	17-21	NA	Dr. Bhupinder Chaudhary

	critique						
3.	Public Healthcare Delivery System: Contemporary HR Policies and Success	Pacific Business Review International	0974 - 438X	Volume 5, Issue 5, November 2012	101 - 108	NA	Dr. Bhupinder Chaudhary
4.	Right to Sight: A Management case study on Aravind Eye Hospitals	Zenith International Journal of Multidisciplinary Research	2231 - 5780	Vol.2, Issue 1, January 2012	447 - 457	NA	Dr. Bhupinder Chaudhary
5.	Retail Management Scenario in India	Journal of Asian Business Management	0974 - 8636	Vol. 2, No. 1, January-June 2010	81-89	NA	Dr. Bhupinder Chaudhary
6.	Information Technology : Redefining Healthcare in the 21 st Century	International Journal of Medicine 'Proficient'	0975 - 847X	Issue-1, Vol-1, January 2010		NA	Dr. Bhupinder Chaudhary
7.	Disease Management- A study on Cardiology Patients	International Journal of Medicine 'Proficient'	0975 - 847X	Issue-1, Vol-1, January 2010		NA	Dr. Bhupinder Chaudhary
8.	Medication Error: A case study	Journal of Academy of Hospital Administration	0970 - 9542	Vol. 21, No. 1 & 2, Jan-June & July-Dec 2009		NA	Dr. Bhupinder Chaudhary
9.	A pragmatic study of	Asian Journal of Research in Business	2249 - 7307	Vol 2 & Issue 11 November		0.376	Mr. Nimesh Bhojak

	consumer preferably on mobile banking in Gujarat	Economics and Management		er 2012			
10.	Study the growth & trend of carbon market in India	Global Journal for Research Analysis	2277 - 8160	Vol 2 & Issue 08 August 2013		0.2714	Mr. Nimesh Bhojak
11.	Study the Carbon Emission around the globe with special reference to India	Current World Environment An International Journal of Environmental Science	0973 - 4929	Vol 3 & Issue 08 December 2013		1.0058	Mr. Nimesh Bhojak
12.	Carbon Finance: Scope for the sustainable development of India	Asian Journal of Research in Banking and Finance	2249 - 7323	Vol 3 & Issue 12 December 2013		1.0962	Mr. Nimesh Bhojak
13.	Development of Credit Rating Model for Bank-loan Rating	International Journal of Research in Commerce, IT & Management	2231 - 5756	October 2011	112		Dr. K.K. Patel
14.	A Study on Impact of Organized Retailer on Unorganized Retailer	International Journal of Research in Management, Economics and Commerce	2250 - 0575 X	May 2012, Volume-2, Issue-5			Dr. K.K. Patel

National Journal:

Sr	Title of	Name of	ISS	Volume	Pag	Impac	Author
----	----------	---------	-----	--------	-----	-------	--------

Sr.	Paper	Journal	N No.	Issue	Page No:	Impact Factor	Author
1.	Health Expert System: New Era in Health Care	E-health	0973 - 8959	Issue- 10, Vol-5, October 2010	27-29	NA	Dr. Bhupinder Chaudhary
2	Impact of Exchange Rate Fluctuation on Micro Economic Factors in India	Conference Proceedings of Gujarat Technological University	978-81-9237 - 874-9	September 2014	341		Dr. K.K. Patel
3	Impact of Service Quality on Customer Loyalty In Private & Public Sector Banks	PROTSAHAN	2321 -869	September 2013	376		Dr. K.K. Patel
4	Innovations in Indian Banking Services: Emerging Trends, Issues & Challenges	ANARTA	2229 - 4376	January-March-2013, Volume-14, Issue-1	69		Dr. K.K. Patel

* Monographs; NIL

* Chapters in Books: 2

Sr.	Title of Book/Chapter	Publisher	ISBN No.	Year	Author
-----	-----------------------	-----------	----------	------	--------

1.	A chapter 'Impact of Software reusability in Health Industry' published in the book titled 'Healthcare and Hospital Management: Contemporary Issues and Strategies' (pp 144-149)	Excel Books, New Delhi, India	978-93-5062-540-8	2014	Dr. Bhupinder Chaudhary
2.	A chapter on 'HRM issues in public healthcare delivery system in India' published in the book titled 'HRM challenges and choices- Vol-2' (pp 242-248)	Desh Bhagat Institute of Management & Computer Sciences Mandi Gobindgarh - 147301 (Punjab) India	978-81-910125-9-0	2012	Dr. Bhupinder Chaudhary

- * Edited Books: NIL
- * Books with ISBN with details of publishers:
- * Number listed in International Database (For e.g. Web of Science, Scopus, Humanities International Complete, Dare Database - International Social Sciences Directory, EBSCO host, etc.) : NONE
- * Citation Index – range / average
- * SNIP
- * SJR
- * Impact Factor – range / average : Total IF:
- * h-index:

23. Details of patents and income generated
NA

24. Areas of consultancy and income generated
NA

25. Faculty selected nationally / internationally to visit other laboratories / institutions / industries in India and abroad : NONE

26. Faculty serving in

- a) National committees b) International committees c) Editorial Boards
d) any other (please specify): NONE

27. Faculty recharging strategies (UGC, ASC, Refresher / orientation programs, workshops, training programs and similar programs).

- Faculties regularly attend and participate in ASC Refresher courses, orientation programs, workshops, training programs and similar programs . The details are as follows:

Name of The Faculty: Dr. K. K. Patel

Sr. No.	Programme Attended	Title of the Programme	Date	Organizer
01	Workshop	Importance of Legal Education in 21 st Centaury	21 st October 2010	V. S. Patel Law College, Unjha
02	Workshop	Capacity Building	15 th October 2010	Knowledge Consortium of Gujarat.
03	Workshop	Research Initiatives	21 st October 2010	HNGU, Patan.
04	Workshop	<i>CBCS and Internal Evaluation</i>	20 th Nov- 2010	HNGU, Patan
05	Workshop	Management of Higher Education in Gujarat State	10 th Dec- 2010	HNGU, Patan
06	Workshop	<i>Right to Information Act 2005 at a glance</i>	28 th Dec- 2010	Department of Law, HNGU, Patan.
07	International Conference	<i>Management Education in 2020: Issues, Challenges & Opportunities.</i>	1-4 January 2011.	IIM, Ahmedabad.
08	Workshop	<i>Criminalization of Politics: A Serious Threat to Our Democracy</i>	8-9 January 2011.	Seth M. N. Law College, Patan.
09	Conference	<i>Hospitals & Health Care Management: Emerging Trends,</i>	26 th March 2011	Department of Hospital Management, HNGU, Patan.

		<i>Issues and Challenges.</i>		
10	MDP	<i>Quality Aspects in Healthcare Administration</i>	23-25 MARC H 2011.	Department of Hospital Management, HNGU, Patan.
11	International Seminar	<i>Creating Excellence for Sustainable Society</i>	15-16 May 2011	Hemchandracharya North Gujarat University, Patan.
12	FDP	<i>Research Analysis with SPSS</i>	31 July To 2 nd August 2011.	SKCBM, HNGU, Patan.
13	Conferance	<i>Financial Market & Corporate Governance: Emerging Trends, Issues & Challenges</i>	24-25 March 2012.	S. K. School of Business Management, HNGU, Patan.
14	Conference	<i>Acharya Mahpragyas Theory of Relative Economics and Corporate Social Responsibility: Translating Theory in to Action</i>	14-15 April 2013	International Research Institute of Relative Economics
15	Seminar	<i>Wild Life and Natural Resources Conservation</i>	4 th March 2014	Forest Department, Government of Gujarat.
16	Seminar	<i>Discrimination Against Women</i>	24 th Sept- 2014	Women's International League for Peace .
17	Training	<i>Internal Assessor Programme</i>	14 TO 16 Nov.- 2014	Quality Council of India

‘Name of the Faculty: Dr. Bhupinder Chaudhary

Sr. No.	Programme Attended	Title of the Programme	Date	Organizer
01	Conference	Innovations in Healthcare Management	Sept- 2010.	Ahmadabad Management Association.
02	Workshop	Research Initiatives	Oct- 2010	HNGU, Patan
03	Conference	Health Care Management: Emerging Trend, Issues & Challenges	March- 2011	Department of Hospital Management, HNGU, Patan.
04	Workshop	<i>Scope & Domain of Hospital Administration</i>	August- 2011	Department of Hospital Management, HNGU, Patan.
05	Conference	Health Care Management: Emerging Trend, Issues & Challenges	Nov-2011	Department of Hospital Management, HNGU, Patan.
06	Conference	<i>Contemporary Issues in Business Management & Finance</i>	Sept-2012	University of Kashmir, Srinagar.
07	Seminar	<i>Interdisciplinary Approaches to Knowledge</i>	April-2014	PDP, Gandhinagar.
08	Workshop	<i>Disaster Management in Hospitals</i>	June-2009	Seeds India Jamnagar
09	Training	<i>First Responders Training</i>		GVK EMRI 108
10	MDP	<i>Quality Aspects in Healthcare Administration</i>	March- 2011	Department of Hospital Management, HNGU, Patan.
11	Training	<i>Internal Assessor Programme</i>	Oct-2011	QCI
12	FDP	<i>Research Analysis with</i>	31-07-2011 to	SKCBM, HNGU,

		<i>SPSS</i>	02/08/2011	PATAN
13	Training	<i>RTI Record keeping & Office Procedure</i>	February-2012	SPIPA
14	Conference	<i>Business Opportunities & Challenges in South Asia</i>	October-2009	Punjab Commerce & Management Association .
15	Conference	<i>Challenges in Human Resources Management</i>	Sept-2012	Desh Bhagat Institute of Management & Computer Science, Punjab.
16	Orientation/Summer School	<i>Disaster Management</i>	18 June 2013 To 8 July 2013	Academic Staff College, DAVV, Indore
17	Refresher Course	<i>Commerce & Management</i>	30Oct 2014 To 19 Nov 2014	Academic Staff College, Gujarat University, Ahmadabad.

Name of the Faculty: Prof. Nimesh Bhojak

Sr. No.	Programme Attended	Title of the Programme	Date	Organizer
01	Conference	New Dimensions in Management Striving for Business excellence	07 February 2010	Gardvidyapith Rajkot
02	Conference	Contemporary issue in commerce & Mangement	20 th February 2010	Shree G.K & C.K. Bosamia Arts & Commerce College, Jetpur
03	Conference	Business Strategy & India's Economic	20 th February 2012	R.B Institute of Management, Ahmedabad

		growth		
04	Conference	<i>Healthcare in 21st century emerging trend & approaches</i>	23 rd & 24 th January 2014	IIHMR, Bangalore
05	Conference	GNU FMS emerging perspective practice & research trend in global marketing	7 & 8 th February 2014	Ganpat University, Kherva
06	Seminar	<i>Challenges , Opportunities & Innovations in Pharmaceutical Sciences</i>	13 th Feb- 2014	Department of Pharmaceutical Sciences, HNGU, Patan
07	Training	<i>Internal Assessor Programme</i>	14 TO 16 Nov.- 2014	QCI
08	Training	<i>SHAKSHAM IT Champion Training Programme</i>	24-29 March 2014	Microsoft
09	Workshop	<i>Country Studies on Africa & Asian Countries</i>	19 May- 2013	Gujarat Technological University, Ahmedabad.

28. Student projects

- percentage of students who have done in-house projects including inter-departmental projects: - None --
- percentage of students doing projects in collaboration with other universities / industry / institute: 100%

29. Awards / recognitions received at the national and international level by :
NONE

30. Seminars/ Conferences/Workshops organized and the source of funding (national / international) with details of outstanding participants, if any.

Title seminar/Conference/Workshop	of	International/National/State	Date

Hospital & Healthcare Management: Emerging Trends, Issues and Challenges	National	March 23 rd -25 th , 2011
“Management Development Programme on Quality Aspect In Healthcare Administration	National	March 26 th , 2011.
Health Care Management: Emerging Trend, Issues & Challenges	National	November 2011.

31. Code of ethics for research followed by the departments : ----- NA ---
--

32. Student profile programme-wise:

Name of the Programme (refer to question no. 4)	Applications received	Selected		Pass percentage	
		Male	Female	Male	Female
Master of Hospital Mgt.	60	14	24	100%	
PGDHM	Nominated by Govt.	Nominated by Govt.		Nominated by Govt.	

33. Diversity of students

Name of the Programme (refer to question no. 4)	% of students from the same university	% of students from other universities within the State	% of students from universities outside the State	% of students from other countries
Master of Hospital Mgt.	21%	76%	3%	---

34. How many students have cleared Civil Services and Defence Services examinations, NET, SET, GATE and other competitive examinations? Give details category-wise. N/A

35. Student progression

Student progression	Percentage against enrolled
UG to PG	---
PG to M.Phil.	--
PG to Ph.D.	---

Student progression	Percentage against enrolled
Ph.D. to Post-Doctoral	--
Employed <ul style="list-style-type: none"> • Campus selection • Other than campus recruitment 	100%
Entrepreneurs	NA

36. Diversity of staff

Percentage of faculty who are graduates	
of the same university	1
from other universities within the State	2
from universities from other States	1
from universities outside the country	0

37. Number of faculty who were awarded M.Phil., Ph.D., D.Sc. and D.Litt. during the assessment period: One

38. Present details of departmental infrastructural facilities with regard to

- a) Library: Yes
- b) Internet facilities for staff and students: Yes
- c) Total number of class rooms: 4
- d) Class rooms with ICT facility: 2
- e) Students' laboratories: Yes
- f) Research laboratories: N/A

39. List of doctoral, post-doctoral students and Research Associates:

- a) from the host institution/university: Not Available
- b) from other institutions/universities: Not Available

40. Number of post-graduate students getting financial assistance from the university. NA

41. Was any need assessment exercise undertaken before the development of new programme(s)? If so, highlight the methodology:
Looking to the need of healthcare industry the syllabus is revised every three years. The inputs of industry personnel are taken while revising syllabus.

42. Does the department obtain feedback from

- a. faculty on curriculum as well as teaching-learning-evaluation? If yes, how does the department utilize the feedback?
Yes University has prepared online tool. The department also undertakes feedback of faculty on curriculum as well as teaching-

learning-evaluation

- b. students on staff, curriculum and teaching-learning-evaluation and how does the department utilize the feedback?

Yes University has prepared online tool.

- c. alumni and employers on the programmes offered and how does the department utilize the feedback?

Alumni feedback is regular exercise of the department. The feedback is used for changes in projects and placement guidelines.

43. List the distinguished alumni of the department (maximum 10)

1. Dr. Pradhyumansinh Rathod – Working at Govt. of Gujarat.
2. Dr. Naresh Garg – Working at Department of Health & Family Welfare, , Govt. of Gujarat.
3. Dr. Vipul Modi – Chairman, Doctor House, Patan
4. Dr. Swity Shah – District Project Officer, National Rural Health Mission, Govt. of Gujarat.
5. Dr. Hariyali Upadhyay - District Project Officer, National Rural Health Mission, Govt. of Gujarat.
6. Dr. Bhupendra Makwana: Asst. Hospital Administrator, National Rural Health Mission, Govt. of Gujarat.
7. Dr. Isha Joshi – Corporation Programme Coordinator, , National Rural Health Mission, Govt. of Gujarat.
8. Dr. Vaibhav Darji- District Project Officer, National Rural Health Mission, Govt. of Gujarat.
9. Dr. Mayur Dodia - District Project Officer, National Rural Health Mission, Govt. of Gujarat.
10. Dr. Neha Prajapati - District Project Officer, National Rural Health Mission, Govt. of Gujarat.

44. Give details of student enrichment programmes (special lectures / workshops / seminar) involving external experts.

The department frequently invites the CEO, Executive, Director, Dy. Directors level personnel as external experts for guest talk.

45. List the teaching methods adopted by the faculty for different programmes.

- Power-point presentations, animations, Audio-visual facilities often used by faculties in lectures. Quizzes and Case based learning methods are used for skill development.

46. How does the department ensure that programme objectives are constantly met and learning outcomes are monitored?

- Feedback forms are filled by students and past students profile are regularly updated on terms of getting employments of students. The department has sound alumni and advice of alumni members

helps to met programme objectives.

47. Highlight the participation of students and faculty in extension activities.
NA
48. Give details of “beyond syllabus scholarly activities” of the department.
- Students are motivated to participate in conference / seminars/ workshops and presenting poster or oral.
 - Tours are organized regularly.
 - Regular industry visits are scheduled.
 - Organized blood donation camps as societal activity.
49. State whether the programme/ department is accredited/ graded by other agencies? If yes, give details.: NO
50. Briefly highlight the contributions of the department in generating new knowledge, basic or applied.
- a. Students are made aware of latest happenings in health care management and governments practices for health care sector.
 - b. Balance between class room teaching and industry internship.
 - c. Encouraging students to read newspapers, magazines and latest books available in the library.
51. Detail five major Strengths, Weaknesses, Opportunities and Challenges (SWOC) of the department.
- Strength: Good Infrastructure, library facility, Placement Record, MOU with QCI, AHA and Corporate Hospitals.
 - Weakness: Lacking of students research activity, Lack of teaching staff.
 - Opportunities: International and National collaboration for faculty exchange, student exchange and research.
 - Challenges: Creating research culture for students and faculty, Continuous up gradation of research infrastructure, Limited participation by students in co-curricular activities.
52. Future plans of the department.
- To create Excellency in teaching and learning.
 - To avail consultancy from industry and government.
 - To make more national and international collaborations.
 - To improve the research base of faculty members and students.

Evaluative Report of the Department of Architecture

1. Name of the Department : Institute of Architecture
2. Year of establishment: 2008
3. Is the Department part of a School/Faculty of the university? YES
4. Names of programmes offered: UG-B.Arch., PG-Master of Urban Planning
5. Interdisciplinary programmes and departments involved : NO
6. Courses in collaboration with other universities, industries, foreign institutions, etc. : NO
7. Details of programmes discontinued, if any, with reasons :NO
8. Examination System: Semester System
9. Participation of the department in the courses offered by other departments: NO
10. Number of teaching posts sanctioned, filled and actual (Professors/Associate Professors/Asst. Professors/others)

	Sanctioned	Filled	Actual (including CAS & MPS)
Professor	02	-	-
Associate Professors	03	01	-
Asst. Professors	04	01	-
Others (Teaching Asst)			

11. Faculty profile with name, qualification, designation, area of specialization, experience and research under guidance

Name	Qualification	Designation	Specialization	No. of Years of Experience	No. of Ph.D./ M.Phil. students guided for the last 4 years

Name	Qualification	Designation	Specialization	No. of Years of Experience	No. of Ph.D./ M.Phil. students guided for the last 4 years
Ar. Rajesh Mehta	B.Arch. Master in Urban Planning	Associate Professor	Architecture & Town Planning	21	
Ar. Mayank Patel	B.Arch.	Assistant Professor	Architecture	19	
Er. Vikas Patel	B.E. Civil, M. E. Structure	Government Department Arts	Artist	Paintings	-
Ar. M/S Kiran Patel	B.Archi.	Assistant Professor	Architecture	3	
Ar. Mitesh Asavadiya	B.Archi.	Assistant Professor	Architecture	2	

12. List of senior Visiting Fellows, adjunct faculty, emeritus professors : --
1. Ar. Hemant Wala
 2. Ar. M/S Kumud Mukerjee
 3. Ar. M/S Meera Chetwani
 4. Sandip Shah
 5. Ar. Kaushik Panchal
13. Percentage of classes taken by temporary faculty – programme-wise information :50 %
14. Programme-wise Student Teacher Ratio: 1 : 10
15. Number of academic support staff (technical) and administrative staff: sanctioned, filled and actual: One Clerk, One Technical Assistant, Two Peon, One Workshop Carpenter, One Librarian.
16. Research thrust areas as recognized by major funding agencies : U.G.C. Grant and Grade under Grant-in-aid fund.
17. Number of faculty with ongoing projects from a) national b) international funding agencies and c) Total grants received. Give the names of the

- funding agencies, project title and grants received project-wise. :
- Rajesh Mehta
- (1) Town Development of Patan, 1,50,000 found, funded by world class University.
- (2) Development of Patan region / vision plan, State Government, Gujarat
18. Inter-institutional collaborative projects and associated grants received :
NIL
a) National collaboration b) International collaboration
19. Departmental projects funded by DST-FIST; UGC-SAP/CAS, DPE; DBT, ICSSR, AICTE, etc.; total grants received. : NIL
20. Research facility / centre with : NIL
- State recognition
 - National recognition
 - International recognition
21. Special research laboratories sponsored by / created by industry or corporate bodies : (1) Material Lab
(2) Environment Lab
22. Publications:
- * Number of papers published in peer reviewed journals (national/international): NIL
 - * Monographs : NIL
 - * Chapters in Books : NIL
 - * Edited Books : NIL
 - * Books with ISBN with details of publishers
 - * Number listed in International Database (For e.g. Web of Science, Scopus, Humanities International Complete, Dare Database - International Social Sciences Directory, EBSCO host, etc.) NIL
 - * Citation Index – range / average : NIL
 - * SNIP :NIL
 - * SJR : NIL
 - * Impact Factor – range / average : NIL
 - * h-index : -- NIL
23. Details of patents and income generated :NIL
24. Areas of consultancy and income generated:
Institute P.G. Course made consultancy with Patan Town planning Authority.

25. Faculty selected nationally / internationally to visit other laboratories / institutions / industries in India and abroad :
- (1)Kauhik Panchal, Member of Board of Study, Institute of Architech Nirma University, Gujarat
26. Faculty serving in : NIL
- a) National committees b) International committees c) Editorial Boards d) any other (please specify)
27. Faculty recharging strategies (UGC, ASC, Refresher / orientation programs, workshops, training programs and similar programs). :
- (1)Teachers training programmed for faculty recharging attended by our faculty.
- (2)Workshops on various subject organized by Institute.
28. Student projects
- percentage of students who have done in-house projects including inter-departmental projects :
 - percentage of students doing projects in collaboration with other universities / industry / institute
29. Awards / recognitions received at the national and international level by :
- Faculty : Ar. Rajesh Mehta, Global achievers Award
 - Doctoral / post doctoral fellows
 - Students
30. Seminars/Conferences/Workshops organized and the source of funding (national / international) with details of outstanding participants, if any. :-
-
31. Code of ethics for research followed by the departments : AS PER UNIVERSITY NORMS
32. Student profile programme-wise:

Name of the Programme (refer to question no. 4)	Applications received	Selected		Pass percentage	
		Male	Female	Male	Female
JUNE-2010	Gujarat Centralized Admission procedure carried out through Admission committee for profession course (ACPC), Ahmedbad				
JUNE-2011					
JUNE-2012					
JUNE-2013	15				

33. Diversity of students

Name of the Programme (refer to question no. 4)	% of students from the same university	% of students from other universities within the State	% of students from universities outside the State	% of students from other countries
UG., PG (AY:2010)	NA/-	NA/-	NA/-	NA/-
UG., PG (AY:2011)	NA/-	NA/-	NA/-	NA/-
UG., PG (AY:2012)	NA/-	NA/-	NA/-	NA/-
UG., PG (AY:2013)	30%	70%	-	-

34. How many students have cleared Civil Services and Defence Services examinations, NET, SET, GATE and other competitive examinations? Give details category-wise. **Nil**

35. Student progression

Student progression	Percentage against enrolled
UG to PG	
PG to M.Phil.	NA
PG to Ph.D.	NA
Ph.D. to Post-Doctoral	NA
Employed	
• Campus selection	-
• Other than campus recruitment	-
Entrepreneurs	--

36. Diversity of staff

Percentage of faculty who are graduates	
of the same university	-
from other universities within the State	100%
from universities from other States	-
from universities outside the country	-

37. Number of faculty who were awarded M.Phil., Ph.D., D.Sc. and D.Litt. during the assessment period : **NIL**

38. Present details of departmental infrastructural facilities with regard to

- Library: Library with reading hall
- Internet facilities for staff and students: Available
- Total number of class rooms: 8 Rooms + Computer Lab+ Workshop
- Class rooms with ICT facility: **NIL**

- e) Students' laboratories: Computer Lab + Workshop
 f) Research laboratories:
39. List of doctoral, post-doctoral students and Research Associates
 a) from the host institution/university: NIL
 b) from other institutions/universities: NIL
40. Number of post graduate students getting financial assistance from the university. : NIL
41. Was any need assessment exercise undertaken before the development of new programme(s)? If so, highlight the methodology.
 NO
42. Does the department obtain feedback from
- a. faculty on curriculum as well as teaching-learning-evaluation? If yes, how does the department utilize the feedback?
 Yes, Informal method of feedback. Suggestion are discussed in BoS and then incorporated in modified syllabus.
 - b. students on staff, curriculum and teaching-learning-evaluation and how does the department utilize the feedback?
 Yes, Informal method of feedback. Suggestion are discussed in staff meeting and accordingly action is being taken.
 - c. alumni and employers on the programmes offered and how does the department utilize the feedback?
 Yes, Informal method of feedback. Suggestion are discussed in staff meeting and accordingly action is being taken.
43. List the distinguished alumni of the department (maximum 10) :
 Nil
44. Give details of student enrichment programmes (special lectures / workshops / seminar) involving external experts.
 Nil
45. List the teaching methods adopted by the faculty for different programmes.
1. Structured Lectures
 2. Seminars
 3. Project Assignment
 4. Field Visits

5. Guest Lectures

6. Discussions

46. How does the department ensure that programme objectives are constantly met and learning outcomes are monitored?

With the help of continuous evaluation and placement of the students. Also from feedbacks received from corporate recruiters and alumni network.

47. Highlight the participation of students and faculty in extension activities.

Nil

48. Give details of “beyond syllabus scholarly activities” of the department.

Heritage walk to Rani Ki Vav

49. State whether the programme/ department is accredited/ graded by other agencies? If yes, give details.

No

50. Briefly highlight the contributions of the department in generating new knowledge, basic or applied.

Nil

51. Detail five major Strengths, Weaknesses, Opportunities and Challenges (SWOC) of the department.

Strength

Good academic environment and physical infrastructure.

Weakness

Dearth of faculty members

Opportunity

Introduce new diploma programmes.

Challenges

Attitude of students towards language.

52. Future plans of the department.

Quality Education in Education

Evaluative Report of the Department of Life Science

1. Name of the Department : Department of Life science(Including Environment Science & Microbiology)
2. Year of establishment : November 1998
3. Is the Department part of a School/Faculty of the university?
Yes, Faculty of the university
4. Names of programmes offered (UG, PG, M.Phil., Ph.D., Integrated Masters; Integrated Ph.D., D.Sc., D.Litt., etc.)
Department is offering Master Degree in Botany, Environmental Science and Microbiology, M. Phil in Life Sciences and Postgraduate Diploma in Medical Laboratory technology and Industrial safety and environment management. Ph. D. is offered in Botany , environment and Microbiology.
5. Interdisciplinary programmes and departments involved
6. Courses in collaboration with other universities, industries, foreign institutions, etc.
7. Details of programmes discontinued, if any, with reasons
8. Examination System: Annual/Semester/Trimester/Choice Based Credit System : CBCS
9. Participation of the department in the courses offered by other departments : Yes
10. Number of teaching posts sanctioned, filled and actual (Professors/Associate Professors/Asst. Professors/others)

	Sanctioned	Filled	Actual (including CAS & MPS)
Professor	01	01	-
Associate Professors	02	Nil	Nil

Asst. Professors	04	03	-
Others	-	-	-

11. Faculty profile with name, qualification, designation, area of specialization, experience and research under guidance

Name	Qualification	Designation	Specialization	No. of Years of Experience	No. of Ph.D./ M.Phil. students guided for the last 4 years
Dr. S. A. Bhatt	M.sc(Micro), Ph.D(Micro)	Professor & Head	Microbiology	22 Years	06 Ph.D 11 M.Phil
Dr. N. A. Dharaiya	M. Sc. (Animal Sciences), Ph. D(Zoology), CBWM and EL Smithsonian Mason Programme, USA	Assistant Professor	Environmental Science	16 years	Ph.D. : 7 (Awarded: 4 Pursuing: 3) M.Phil: 6
Dr. Illa C. Patel	M. Sc. (Botany), M. Phil. (Plant Physiology), Ph. D. (Botany)	Assistant Professor	Botany	12 Years	06 Ph.D 04 M.Phil
Dr. R. K. Patel	M. Sc. (Micro), M. Sc. (Ecology & Environment Science), PG Diploma (Bioinformatics), Ph. D. (Microbiology)	Assistant Professor	Microbiology	More than 14 Years	

12. List of senior Visiting Fellows, adjunct faculty, emeritus professors

Microbiology :

- (1) Prof. S. R. Dave
- (2) Dr. H. A. Modi
- (3) Dr. B. K. Jain
- (4) Dr. M. D. Shukla
- (5) Dr. P. B. Acharya
- (6) Dr. J. P. Patel
- (7) Dr. Payal Patel
- (8) Dr. Kamlesh Shah
- (9) Dr. Vijaya Nadaganda
- (10) Dr. Sanjay Patel
- (11) Dr. Mehul Dave
- (12) Dr. U. K. Jani

Environmental Science :

- (1) Dr. Darshan Marjadi, Surat
- (2) Dr. M. G. Thakkar, Bhuj
- (3) Dr. C. P. Singh, ISRO, Ahmedabad
- (4) Ms. Minal Upadhyay, Palanpur
- (5) Mr. Santi Chauithari, GMDC, Ahmedabad
- (6) Ms. Megha Patel, Ahmedabad
- (7) Dr. K.U. Mistry, Chairman, GPCB, Gandhinagar
- (8) Dr. Jagruti Sangavi, DST WOS, Bhuj
- (9) Dr. Dinesh Pancholi, GMDC, Ahmedabad
- (10) Dr. Kumud D Patel, Patan
- (11) Prof. M. B. Prajapati, Patan
- (12) Dr. Shuhash Vyas, Bhuj

Botany :

- (1) Dr. B.L. Punjani
- (2) Jitendra Panigrahi
- (3) Rupesh Jha
- (4) C. V. Jha
- (5) Jagruti Sanghani

PGIS :

- (1) Dr. K. U. Mistry
- (2) Dr. Dinesh A. Pancholi
- (3) Shri Mitul Deliya

Title	Agency	Sanction Date	Period	Amount	Major/Minor
An Arboretum	Narmada Nigam Ltd		2014	Lakhs	
Coastal Wetlands...	UGC, New Delhi		2012-2015	9.68 Lakhs	Major
Carbon Sequestration	GujCOST		2013-2016	1.38 Lakhs	Minor
Name of Department : Life Science					
Name of Faculty : Dr. Illaben Patel					
Effect of Brassinosteroids on protein profiling of some groundnut cultivars under salinity stress.	UGC	March 2013	3 years	9,08,800/-	Major
Development of effective propagation methods for some conservation concern medicinal plants of North Gujarat	World class university development fund, H N G University, Patan	July 2013	1 year	1,20,000/-	Minor
Name of Department : : Department of Life Sciences					
Name of Faculty : Dr. Rajesh Patel					
Study on synergistic effect of phytochemicals with antibiotics against multidrug resistance bacteria	UGC (Ref UGC F/41/361/2012, Date july 13, 2012	15-Jul-2012	2	10,91,800	Major
Diversity and Biotechnological application of Endophtic Microflora from Saline Desert	World class university development fund, H N G University, Patan	18-Jun-2013	1	100000	Minor

18. Inter-institutional collaborative projects and associated grants received : Nil

a) National collaboration

b) International collaboration

19. Departmental projects funded by DST-FIST; UGC-SAP/CAS, DPE; DBT, ICSSR, AICTE, etc.; total grants received. : Nil

20. Research facility / centre with : With state & international recognition

- state recognition
- national recognition
- international recognition

21. Special research laboratories sponsored by / created by industry or corporate bodies : Nil

22. Publications:

- Number of papers published in peer reviewed journals (national / international) :

Dr. S A Bhatt

No.	Title of Research Paper	Journal name	ISSN No	Volume No (Issue)	Page No	Impact Factor
1	Bacterial Diversity of Industrially Important Hydrolases Producer from Lonar Lake, India	Life Sciences Leaflets	2277-4297	11	129-137	0.92
2	Isolation, Characterization And Investing The Industrial	International Journal of Applied Sciences and	2091-2609	2(1)	75-82	

	Applications Of Thermostable And Solvent Tolerant Serine Protease From Hot Spring Isolated Thermophilic Bacillus Licheniformis U1	Biotechnology				
3	Molecular characterization of mangrove plants-a review	Life sciences leaflets	2277-4297	48(2014)	148- 158	0.93
4	Biochemical and genetic identification of solvent tolerant novel Bacillus subtilis Pa2.	Journal Biochem Technology				0.94
5	Characterization and phylogenetic relatedness of Azotobacter salinestrus	Journal of Microbiology and Biotechnology research	2231-3168	3(1)	65- 70	
6	Degradation Of Organophosphate And Orga- Nochlorine Pesticides In Liquid Culture By Marine Isolate Nocardiopsis Species And Its Bioprospectives	Journal of Environmental Research And Development	2319-5983	7(2A)	995- 1001	0.61
7	Enumeration, isolation and Identification of free livings Diazotrophs from different soils of North Gujarat region, India.	NA				
8	Azotobacter salinesteris having	Proceeding of national	978-81- 923514-0-7			

	dual capacity of Nitrogen fixation and biosurfactant production, isolated from North Gujarat soil, India	conference on Advance trends in Applied science and technology				
9	Biochemical and genetical identification of solvent tolerant novel <i>Bacillus subtilis</i> Pa2	J Biochem Tech		3(4)	380-383	0.94
10	Diazotrophic diversity as a functional diversity in indices in semi arid soil of Patan(North Gujarat)	Environmental Science (ESAIJ)	0974-7451	6(4)	212-214	
11	Diversity of Microbial community composition and function in awning and forage soils of North Gujarat	Life Science Leaflets	ISSN:0976-1098	2	29-37	
12	Isolation and Identification of exopolysaccharide and IAA producing <i>Bradyrhizobium vuanmingense</i> from root nodules of <i>Abrus precatorius</i> L.	Life Science Leaflets	ISSN2277-4297		109-117	
13	Purification and characterization of Lipases from <i>Bacillus subtilis</i> Pa2	J Biochem Tech		3		0.96

14	Evaluation of ground water quality in Banaskantha district, Gujarat, India	Asian Journal of Microbiol. Biotech. Env. Sc.	0972-3005	12(2)	421-425	0.50
15	Impact of biovolume inocula of Azospirillum Spp. On winter wheat, oat and maize in semi arid region of North Gujarat	BioTechnology (BTAIJ)	0974-7435	5(3)	186-190	
16	Medicinally important plant Ocimum sanctum L.: an overview.	Anart:		13(1)	148-155	
17	Microbial diversity & their properties in semi arid barren soils of North Gujarat.	RRBS	0974-7532	5(1)	8-10	
18	Seasonal changes in soil microbial biomass and enzyme activity in arable and barren land. AJMBES	NA		12(2)	1-5	
19	Antimicrobial screening and phytochemical analysis of the resin part of Acacia catechu	Pharmaceutical Biology		47(1)	34-37	
20	Fluoride contamination in ground water of Patan district, Gujarat, India.	International journal of Engineering studies	0975-6469	2(2)	141-147	
21	Qualitative status of ground water in the North Gujarat region of India	Electronic Journal of Environmental Sciences	ISSN:973-9505	2	51-56	

22	Flouride: a Major polluting componemt of ground water in North Gujarat region, India.	Proceeding of Taal 2007: The 12th World Lake conference			245-249	
23	Influence of enzyme activities on microsite, depth and grazing of forage soils of North Gujarat	Environmental Science (ESAIJ)	0974-7451	6(4)	215-218	
24	The effects of estrogens, diethyl stilbesterol(DES) and 17-beta estradiol(E2) on the growth and tissue chemistry of Labeo Rohita	Journal of Vatenery Pharmacology and toxicology		6(1)	38-44	
25	Medicinally important plant Ocimum sanctum L : an overview	Anart:		13(1)	148-155	

Dr. Nishith Dharaiya

No.	Title of Research Paper	Journal name	ISSN No	Volume No (Issue)	Page No	Impact Factor
1	Microbial production of poly-3-hydroxybutyric acid from soybean oil by Bacillus subtilis	European Journal of Experimental Biology	2248-9215	3(5)	141-147	
2	Assessment of wetland status in arid areas of Gujarat using migratory birds as a key indicator	Proceedings of International Wetland Symposium			36-41	

3	Estimating Carbon Sequestration In Forest Vegetation Through Several Scientific Methods: A Review To Find Competent Method For Indian Forests	Abhinav Journal of Science and Technology	2277-1174	2(3)	31-36	
4	Feeding ecology and Habitat Use of Sloth Bear (<i>Melursus ursinus</i>) in Jassore Wildlife Sanctuary, Gujarat, India	Indian Journal of Ecology		40(1)	14-18	
5	Identification of hairs of some.....Gir PA	J Threatened Taxa	0974-7907			
6	Modeling Environmental Niche of Himalayan Birch and Remote Sensing based Vicarious Validation	Tropical Ecology	0564-3295	54 (3)	319-327	
7	Satellite remote sensing for climate change for terrestrial biosphere.	ISG Newsletter	0792-642x	Vol 25 (1)	134-141	0.42
8	Bioprospecting and Characterization of poly- β -hydroxyalkanoate (PHAs) producing <i>Pseudomonas</i> Spp. Isolated	Research in Biotechnology	2229-791x	3(5)	1-08.	

	from edible oil contaminated soil.					
9	Environmental Governance in India	ISG Newsletter.	0792-642x	17 (2)	21-23	
10	Isolation, Screening and Characterization of Polyhydroxy-alkanoates producing bacteria utilizing edible oil as a carbon source.	Journal of Environmental Research and Development.	0973-6921	V (3)		0.16
11	Status, Occurrence, Distribution of Some Mammals of North Gujarat.	Proceedings of Zoological Society	0373-5893	64 (1)	46-53	
12	A better alternative for sustainable future	Everyman's Science	0531-495x	XLV (2)	90-92	
13	Analysis of edible oil contaminated soil within north Gujarat region.	Life Sciences Leaflets	0976-1098		127-134	
14	Seasonal dietary composition of sloth bear (<i>Melursus ursinus</i>) in the reserve forest of Vijaynagar, North Gujarat, India.	Tigerpaper	1014-2789	37 (2)	8-13.	
15	Status and distribution of Gyps vulture in the North Gujarat region	Aanarta: an official Journal of Hemchandracharya North Gujarat University.	2229-4376			
16	An inventory on marine macrofauna and	Bioscience Reporter	2277-9493	8(1)	21-24	

	their diversity at intertidal zone with respect to marine pollution around Alang Ship Recycling Yard, Gulf of Cambay, Gujarat.					
17	Ecological studies on leopard (<i>Panthera pardus</i>) with special reference to habitat use and feeding patterns in Girnar Wildlife Sanctuary, Gujarat, India.	Life Sciences Leaflets	0976-1098	4	127-134	
18	Avifaunal community in the village ponds adjoining the wild ass sanctuary, Gujarat.	Adv. Bio. Sci	2156-8456	6 (1)		1.27
19	Escalating Human-Bear Conflicts in North Gujarat: A Tough time to encourage support for Bear conservation	International Bear News	1064-1564	18 (3)	12-14	
20	Feeding patterns and den ecology of striped hyena (<i>Hyaena hyaena</i>) in North Gujarat, India	Tigerpaper	1014-2789	36(1)	13-17	0.07
21	Life Cycle assessment of some Indian steel industries with special reference	Journal of Env. Research and Development	0973-6921	2(4)	773-781	0.16

	to climate change					
22	Marsh bird community index of biotic integrity: A key to study an ecological condition of wetlands.				558-561	
23	Nesting ecology of some terrestrial birds in Danta Forest Range, North Gujarat	Journal of Endangered Texa.	0974-7907			
24	Study on Microbial Diversity of Wild Ass Sanctuary, Little Rann of Kutch, Gujarat, India.	The ICFAI University Journal of Life Sciences.	0973-8487	3	34-41	

Dr Ilaben Patel

N o	Title of Research paper	Journal name	ISSN No	Volume No (Issue)	Page No.	Impact Factor
1	An overview on <i>Commiphora wightii</i> (Arn.)Bhandari, an endangered plant species of burseraceae family	World Journal of Pharmacy and Pharmaceutical sciences	ISSN 2278 – 4357	3(11)	350-356	2.786
2	Seasonal impact on Quantification of Secondary metabolites <i>In vivo</i> and <i>in vitro</i> in <i>Commiphora wightii</i> (Arn.)Bhandari	International Journal of Current research	ISSN : 0975 - 833X	6(11)	9486 - 9487	3.98
3.	Direct shoot	Indian Journal	2249	3(7)	73-	0.82

	organogenesis from bulbs explants of <i>Polianthus tuberosa</i> cultivars (Prajwal and Shringar)	Of Applied Research	- 555X		75	
4.	Comparative phytochemical analysis of in vitro and in vivo plant parts of <i>Oroxylum indicum</i> (L.) Vent. – an endangered medicinal plant	International Journal of Advances in Pharmaceutical Research	2230 – 7583	4(5)	1701 – 1705	0.52
5.	Phytochemical studies on <i>Mansoa alliacea</i> (Lam.)	International Journal of Advances in Pharmaceutical Research	2230 – 7583	4(6)	1823 – 1828	0.52
6.	Study on Qualitative and Quantitative Estimation of in vivo and in vitro Tissues of <i>Tecomella undulata</i> (Sm.) Seem.	International Journal of Advances in Pharmaceutical Research	2230 – 7583	4(8)	2088 – 2092	0.52
7.	Studies on qualitative and quantitative phytochemical analysis of <i>Piper longum</i> Linn.	International Journal of Pharma and Bio Sciences	0975 – 6299	4(3)	B-1381 – 1388	0.47
8.	Multiple Shoot Regeneration of <i>Polianthes tuberosa</i> Cultivars Phulerajni and Calcutta double	Paripex-Indian Journal of Research	2250 – 1991	3(5)	12-14	0.32
9.	<u>Seasonal And Regional Impact On Primary Metabolites In-Vivo And In-Vitro In <i>Commiphora wightii</i> (Arnott) Bhandari</u>	Advance Research in Pharmaceuticals and Biologicals	ISSN 2250 – 0774	3(4)	538-539	0.57

10.	Biochemical Changes During <i>In Vitro</i> Organogenesis of <i>Tylophora Indica</i> (Burm. F.) Merrill	Indian Journal of Applied Research	2249 - 555X	3(7)	73-75	0.82
11.	Seasonal Effects On Some Phytochemicals Accumulation of <i>Tecomella undulata</i> (Sm.) Seem	Advance Research in Pharmaceuticals and Biologicals	ISSN 2250 --- 0774	4 (I)	639-643	0.51
12.	Study on medicinal plants useful against ulcer from Patan District (Gujarat)	Life Sciences Leaflets	ISSN NO. 0976 - 1098 (On Line), ISSN - 2277 - 4297	19.	804-808	0.92
13.	Studies On Metabolic Responses to Salinity Stress In Groundnut (<i>Arachis hypogaea</i> L.) Cultivars”	Plant Archives, An international Journal of Plant Research). ISSN NO. : 0972 - 5210	10(1)	497-499	NAAS rating -3.0
14.	Studies on Biochemical changes in Tomato (<i>Lycopersicon esculentum</i> L.) cultivars under NaCl Salinity	Plant Archives, An international Journal of Plant Research). ISSN NO. : 0972 - 5210	9(2)	927-930	NAAS rating -3.0
15.	Effect of Plant Growth Regulators on In Vitro Regeneration of <i>Tylophora indica</i>	Plant Archives, An international Journal of Plant Research). ISSN NO. : 0972 -	10(1)	475-477	NAAS rating -3.0

	(Burm.F.)Merr.:A Medicinal Plant.		5210			
16.	In Vitro Shoot Regeneration from Different Explants of Medicinal Plant <i>Plumbago zeylenica</i> (L.)	Plant Archives, An international Journal of Plant Research). ISSN NO. : 0972 - 5210	9(2)	983-985	NAAS rating -3.0
17.	Performance of stored Mungbean (<i>Vigna radiata</i> L.) Seeds pretreated with PGRs	Advances in Plant Sciences	ISSN NO. : 0970 - 3586 , ISSN NO. : 0970 - 3586	20(1)	565-568	NAAS rating -2.7
18.	Changes in flower abscission, fruit drop and yield in Mungbean as influenced by foliar spray of PGRs, urea and KNO ₃	Advances in Plant Sciences	ISSN NO. : 0970 - 3586 , ISSN NO. : 0970 - 3586	21(1)	509-511	NAAs rating 2.7
19.	“Medicinal Flora of Botanical Garden of H.N.G.U. Patan, Gujarat	Adv. Bio. Sci		7(1)	83-86	
20.	Zink induced Physiological and Biochemical Changes in Brinjal <i>Solanum melongena</i> (L.) Seed during Germination	Adv.in Bio. Sci.		7(1)	47-49	
21.	Effect of Salinity on Physiological and Biochemical	International Journal of Plant Archives). ISSN NO. :	7(2)	599-602	NAAS rating 3

	changes of wheat (<i>Triticum aestivum</i> L.) seed during Germination		0972 - 5210			
22.	Modulation of seed germination and seedling performance of <i>Daucuscarota</i> L. under effect of PGRS and plant parts extract of Brassicaceae family	Adv.Bio.Sci		5(2)	71-74	
23.	Indeginous knowledge on Ethnoveterinary study of Patan District.	Plant Archives, An international Journal of Plant Research	ISSN NO. : 0972 - 5210	6(1)	387-388	NAAS rating -3.0

Dr. R K Patel

No .	Title of Research Paper	Journal name	ISSN No	Volume No (Issue)	Page No	Impact Factor
1	Classical and microwave assisted synthesis of new 4-(3,5-dimethyl-1-phenyl-1H-pyrazol-4-ylazo)-N-(2-substituted-4-oxo-4H-quinazolin-3-yl)benzenesulfonamide derivatives and their antimicrobial activities	Journal of Saudi Chemical Society	319-6103			1.29
2	In silico study of novel Dihydropyrimidines against Anti Cancer, Anti Tuberculosis, Anti	Journal of Scientific & Engineering Research	2229-5518	4(3)	18	

	HIV and Anti Malarial activity.					
3	Virtual Screening of Heterobased Ligand library for Protein Kinase Inhibitor for Anti-cancer activity	International Journal of Pharmacy and Pharmaceutical Sciences	0975-1491	Vol 4, (4)		
4	Crowd Sourcing a new paradigm for Interactome Driven Drug Target Identification in Mycobacterium tuberculosis	PLoS ONE	1932-6203			4.09
5	Phenotypic Characterization and Antimicrobial Combination Approach to Control the Methicillin-Resistant Staphylococcus aureus (MRSA) Strain Isolated From the hospital derived fomites	Asian journal of Medical Sciences	2091-0576	2	72-78	
6	Protein Modeling studies for antibacterial drug target	Proceeding of National Confrenfe on Advanced trends in applied sciences and Technology	978-81-923514-0-7		323, 329	
7	Targeting Protein Kinase inhibitor for anti-cancer therapy with Heterocyclic compound Library with in silico drug discovery	Bioinformatica	1	1		

	approach					
8	Virtual Screening for Protein Kinase Inhibitor For anti-cancer application	Bioinformatics		1(1)	16-20	
9	Whole-Genome Shotgun Sequencing of an Indian-Origin Lactobacillus rhamnosus Strain, MTCC 5463, With Probiotic Potential	Journal of Bacteriology	1098-5530	194	1264-1265	4.00
10	New ternary transition metal complexes of 2-[(2 amino phenyl)imino]methyl} phenol and metformin: synthesis characterization and antimicrobial activity	E-journal of chemistry http://www.e-journal.net	0973-3450	6	361-367	
11	Performance Indicators Through Participatory Approach: A Piolt Study of H. N. G. University	Anarta	2229-4376	13	175, 181	
12	Study on Antimicrobial Activity for Normal and Multidrug Resistant Strains for 3-benzensulfonamide substituted quinazolinone derivatives in In-vitro Condition	International journal of pharmaceutical and applied sciences, IJPAS	0976-6936	2		
13	Synthesis characterization and antimicrobial	Ultra chemistry	0976-6936	5	211-220	

	activity of ternary cr (vI) and Fe(III) Metal complexes of 2-{{(2aminop henyl)imino] methyl}phenol And metformin.					
14	Synthesis, Characterization and antimicrobial Activity of Some Transition Metal Complexes (Mn, Co, Zn,Ni) With L-Proline and Kojic Acid	Pelagia Research Library	0976- 8610	2(4)	374- 382	
15	A Study on Isolated diazotrophic (Non- symbiotics) Bacteria from Saline Desert Soil as a Biofertilizer	International journal of pharmaceutic als and applied sciences	ISSN: 0976- 6936		52, 54	
16	Study on Microbial diversity of Wild Ass Sanctuary, Little Rann of Kutch, Gujarat, India	The ICFI University Journal of Life Sciences		3(1)	33, 41	

Monographs

Chapters

in Books

N o.	Title of Book	Title of Chapter	Name of authors as per order in publicat ion	Name of Publisher	ISBN No	Date of Publicat ion
1	Perspecti ves in Science Research	Isolation and identification of nitrogen fixing rhizobium species	J. P. Patel, P. H. Patel, S. G. Patel, S.A.	Registrar , Hemchandrach aya North Gujarat University, Patan	978- 81- 92335 3-3-9	2012

		associated with roots of wild legume from North Gujarat region, India	Bhatt			
2	Perspectives in Science Research	Enumeration, Isolation and Identification of Free living Diazotrophs from different soils of North Gujarat region, India	P. H. Patel, J. P. Patel & S. A. Bhatt	Registrar , Hemchandracharya North Gujarat University, Patan	978-81-923353-3-9	2012
3	Perspectives in Science Research	Assessment of Groundwater Quality for Drinking Purpose in Mehsana District Gujarat India	P. M. Patel, S. G. Patel & S. A. Bhatt	Registrar , Hemchandracharya North Gujarat University, Patan	978-81-923353-3-9	2012
4	Perspectives in Science Research	Isolation and Optimization of polygalacturonase producing Bacterial species from the plant waste dumped soil.	Sanjay Patel, J. P. Patel, P. M. Patel ,Dr. S. A. Bhatt	Registrar , Hemchandracharya North Gujarat University, Patan	978-81-923353-3-9	2012
5	Perspectives in Science Research	Isolation, Identification & a Local Ganoderma SP.	Vijaya Nadagouda, Dr. M. D. Shukla, Dr. S. A. Bhatt	Registrar , Hemchandracharya North Gujarat University, Patan	978-81-923353-3-9	2012

□ Edited

Books

- Books with ISBN with details of publishers

Name of Department : : Department of Life Sciences						
Name of Faculty : Dr.S. A. Bhatt						
No.	Title of Book Chapter	Name of authors as per order in publication	Name of Publisher	ISBN No	Date of Publication	Editor/author
1	Perspectives in Science Research	Dr. S. A. bhatt And Dr. Manoj Lodha	Registrar , Hemchandracharya North Gujarat University, Patan	978-81-923353-3-9	2012	Dr. S. A. bhatt, Dr. Manoj Lodha
Name of Department : : Department of Life Sciences						
Name of Faculty : Dr. Rajesh Patel						
1	Detection of Methicillin-resistant and Methicillin-sensitive Staphylococcus aureus from Employees of a Medical Waste Treatment Plant	Pravin R. Dudhagara , Anjana D. Ghelani, Shakuntala V. Gondalia , Enzo A. Palombo , Rajesh K. Patel	Har Krishan Bhalla & Sons co-published with Taylor & Francis Group	987-81-905771-3-7	2013	

- Number listed in International Database (For e.g. Web of Science, Scopus, Humanities International Complete, Dare Database - International Social Sciences Directory, EBSCO host, etc.)
- Citation Index – range / average
- SNIP
- SJR
- Impact Factor – range / average
- h-index

23. Details of patents and income generated

Funding Agency	Amount	Period
(A) Completed		
UGC	2,00,000/-	2010-11
GUJCOST	18,000/-	2010-11
GSBTM	12,13,480/-	2011
GUJCOST	25,000/-	2010-11
(B) Ongoing		
HNGU, Patan(UGC)	1,20,000/-	2013-14
UGC	9,08,800/-	2013-16
UGC	1,97,500/-	2012-14
UGC	10,19,800/-	2012-14
S.S.N.N.Ltd.	13,14,000/-	2011-14
UGC	9,83,000/-	2012-15
GUJCOST	1,38,000/-	2013-16
HNGU, Patan	1,50,000/-	2013-14

24. Areas of consultancy and income generated :-

(1) Validation and Value addition of some Herbal preparations for their antimicrobial activity from selected herbal plants.

25. Faculty selected nationally / internationally to visit other laboratories / institutions
/ industries in India and abroad : Nil

26. Faculty serving in

a) National committees b) International committees c) Editorial Boards
d) any other (please specify)

Dr. S. A. Bhatt :- Editorial Board – ‘ Life Science leaflets’
Member Board of Governors

1. Kadi Sarva Vishwa Vidhyalaya

Dr. N. A. Dharaiya :- 1. Executive Council Member, International Association for

Bear Research and Management, USA

2. Co-chair, IUCN –SSC, Sloth Bear Expert Team

Dr. Rajesh Patel,

Editor, Bioinformatica Journal

Reviewer in American Journal of Phrama Tech research Journal

27. Faculty recharging strategies (UGC, ASC, Refresher / orientation programs, workshops, training programs and similar programs).

28. Student projects

- percentage of students who have done in-house projects including inter-departmental projects = **7 % (Industrial safety Course)**

- percentage of students doing projects in collaboration with other universities

/ industry / institute = **93 % (Industrial safety course)**

:--- All Sem. IV Students take up Projects in home and in Industry also

Microbiology:-- 50% In house

50% Industry/ Institute

Botany :-- 60% In house

40% Industry/ Institute

Environmental Science : 30% In house

70% Industry/ Institute

29. Awards / recognitions received at the national and international level by

- Faculty

Dr. N. A. Dharaiya :

1. Awarded as a Front line Trainers for Tiger Range Countries under the Global Tiger Initiative of The
2. World Bank and Smithsonian Institution, USA
3. Co- chair, IUCN Bear Specialist Group and Sloth Bear Expert Team
4. Awarded Fellowship from International Tropical Timber Association (ITTO), Japan
5. Awarded fellowship by Indo-US Science and Technology Forum
6. Honored Young Scientist Award for Best Oral Presentation in National Conference on Environmental Biology
7. Awarded Travel fellowship by Smithsonian Institution, Washington, USA
8. Awarded HNGU Research excellence award 2013.

Dr.I. C. Patel:

1. Awarded National Merit Scholarship for M. Sc. From Orissa. 1987-1989.
2. Awarded Gold Medal in M. Sc. Botany, 1989
3. Awarded for Best Paper Presentation, m National Symposium on Biodiversity, PGRs and Biotechnology, Ahmedabad, 1996.

Dr.R. K. Patel:

1. Participated in International Training Course on Drug Development and Neglected Tropical Infectious Diseases, Thailand Science Park, Pathum Thani, Thailand
2. Awarded Young Scientists Travel Fellowship (worth US\$1,000) from Federation of Asian and Oceanic Biochemistry and Molecular Biologist (FAOBMB) for symposium, October 2000, Beijing, China.
3. Awarded Fellowship from United Nations Educational, Scientific and Culture Organization (UNESCO) and International Cell Research Organization (ICRO) for “International Training Course on RNA and Biotechnology”, September, 2001 Shanghai, China.
4. Awarded HNGU Research excellence award 2013

- Doctoral / post doctoral fellows
- Students

30. Seminars/ Conferences/Workshops organized and the source of funding (national / international) with details of outstanding participants, if any.

Schools organized by the PG Department

31. Code of ethics for research followed by the departments :--- All Ethical Standards are Followed.

32. Student profile programme-wise:

Name of the Programme (refer to question no. 4)	Applications received	Selected		Pass percentage	
		Male	Female	Male	Female
Ph.D	-	11	10	-	-
M. Phil	08	03	04	41%	55%
M.Sc	82	30	23	43%	57%
PG. Diploma	41	10	20	77%	08%

33. Diversity of students

Name of the Programme (refer to question	% of students from the same	% of students from other universities within the	% of students from universities outside the	% of students from other

no. 4)	university	State	State	countries
Ph.D	-	-	-	-
M. Phil	43%	57%	-	-
M.Sc	84%	14%	2%	-
PG. Diploma	100%	-	-	-

34. How many students have cleared Civil Services and Defense Services examinations, NET, SET, GATE and other competitive examinations? Give details category-wise. :-

3 Students have cleared NET

35. Student progression

Student progression	Percentage against enrolled
UG to PG	
PG to M.Phil.	9%
PG to Ph.D.	3%
Ph.D. to Post-Doctoral	
Employed	
<input type="checkbox"/> Campus selection	5%
<input type="checkbox"/> Other than campus recruitment	80%
Entrepreneurs	1-2%

36. Diversity of staff

Percentage of faculty who are graduates	
of the same university	0%
from other universities within the State	75%
from universities from other States from	
universities outside the country	25%

37. Number of faculty who were awarded M.Phil., Ph.D., D.Sc. and D.Litt. during

the assessment period: N.A.

38. Present details of departmental infrastructural facilities with regard to

- a) Library : No
- b) Internet facilities for staff and students : Yes
- c) Total number of class rooms : 05
- d) Class rooms with ICT facility :03
- e) Students' laboratories : 06
- f) Research laboratories : 04

39. List of doctoral, post-doctoral students and Research Associates

a) from the host institution/university

Under Supervision of Dr. Nishith Dharaiya					
No	Name of Student	Research Degree Category	Status	Year	Title of Research
1	Mevada Tana	Ph.D.	Completed	2011	Ecological studies on Sloth bear (Melursus ursinus) with special reference to human-bear conflicts in selected sloth bear habitat of north Gujarat.
2	Marjadi Darshan	Ph.D.	Completed	2012	Production of Biodegradable Plastics from Oil Contaminated Sites and its Biotechnological Applications
3	Joshi J.V.	Ph.D.	Completed	2013	Assessment of Mammalian Diversity of Jassore Sloth Bear Sanctuary to suggest its Conservation and Management for Future Prospects
4	Singh C. P	Ph.D.	In Progress	2011	Modeling Dynamics of the Alpine tree line Ecotone in Response to Bioclimatic Scenario
5	Jagiwala Jagruti	Ph. D	In Progress	2011	Estimating Carbon Sequestration From Native Trees: An Approach

					To combat The Climate change
6	Patel Pratik	Ph. D	Thesis Submitted	2014	Study on Aquatic Life form and Their Role in Bioremoval of waste To Develop Treatability Model for Mannade Wetlands
7	Joshi Kajal	Ph. D	In Progress	2012	Assessment of LULC change in Gulf of Kachchh with special reference of conservation of marine ecosystem.
8	Prajapati Rohit	JRF(UG C Project)	In Progress	2012	Monitoring and assessment of Coastal wetlands of Gulf of Kachchh.
9	Joshi Helly	JRF(IS RO Project)	In Progress	2014	Habitat suitability and corridor analysis for Sloth bear in Gujarat using RS and Ecological modeling.
Under Supervision of Dr. Illa Patel					
No	Name of Student	Research Degree Category	Status	Year	Title of Research
1	Asha patel	Ph.D.	Registered	Jun-12	Studies on Mass Multiplication and Phytochemical Analysis of <i>Pterocarpus marsupium</i> (R. Br); An Important Medicinal Plant
2	Dipika Rathod	Ph.D.	Registered	Jun-12	Tissue Culture and Phytochemical Studies of Medicinal Plants <i>Gloriosa superba</i> L. and <i>Celastrus paniculatus</i> Willd
3	Jitendriya Panigrahi	Ph.D.	Registered	Jun-12	Development of Micropropagation techniques and analysis of secondary metabolites of <i>Adhatoda</i> Sps. and <i>Chlorophytum</i> sps.
4	<u>Esha Rami</u>	Ph.D.	Registered	Jun-11	In vitro micropropagation and phytochemical screening of <i>Oroxylum indicum</i> (L) Vent. An endangered medicinal plant
5	Gaurav Shrimali	Ph.D.	Registered	Jun-11	Studies on Influence of Brassinosteroids on Physiological and Biochemical Parameters of Groundnut (<i>Arachis hypogaea</i> L.) under Salinity
6	Shweta N.	Ph.D.	Registered	Jun-	Studies on Micropropagation and

				11	Secondary Metabolite Production of <i>Commiphora wightii</i> (Arn.)Bhandari under Seasonal Variations
Under Supervision of Dr. Rajesh Patel					
No	Name of Student	Research Degree Category	Status	Year	Title of Research
1	Mevada Vishal A	Ph.D.	Registered	Jul-11	Integrative Biology and Systems Biology based Antimalarial Drug Discovery
2	Ghelani Anjana D	Ph.D.	Registered	Jul-11	Marine Microbial diversity and Biotechnological exploration from Coastal region of Gujarat, India
3	Patel Monita V	Ph.D.	Registered	Jul-11	Diversity and Biotechnological application of Endophytic Microflora from Saline Desert
4	Mangrola Amitsingh	Ph.D.	Registered	Jul-12	Study on cultivable and uncultivable microbial Biodiversity & Biotechnological Potential of selected Hot Springs in India
5	Dayma Paras	Ph.D.	Registered	Jul-12	Biosynthesis of Nanoparticles by Desert Actinomycetes isolates from Little Rann of Kutch and Greater rann of Kutch
6	Patel Leena J	Ph.D.	Registered	Jul-12	Study on Anti-MRSA antibiotic Production from Saline Desert Microflora

b) from other institutions/universities

40. Number of post graduate students getting financial assistance from the university. :-
Nil
41. Was any need assessment exercise undertaken before the development of new programme(s)? If so, highlight the methodology. :-
a) On Basis of Student inquiry.
b) On Basis of creating Job opportunities.
42. Does the department obtain feedback from
a. Faculty on curriculum as well as teaching-learning-evaluation? If yes,

how does the department utilize the feedback?

Yes

-- To improve curriculum and make it more professional to increase job

Opportunities.

- b. Students on staff, curriculum and teaching-learning-evaluation and how does the department utilize the feedback?

Yes

-- Department Generally takes feedback from students about curriculum And the faculty also and Their feedbacks are analysed and faculty are taking care to provide better guidance to the students.

- c. Alumni and employers on the programmes offered and how does the department utilize the feedback?

-- Curriculum are sent to the alumni and employers to get . Their views for up gradation in the curriculum so as to in appropriate contemporary

Developments in the subject and students get the benefit in terms of better job opportunities as They are also updated with current developments in the Subjects.

43. List the distinguished alumni of the department (maximum 10) :-

- 1) Mr. Deepak Pandya – Claris, Ahmadabad.
- 2) Mrs. Ratna Trivedi – Assistant Professor, Surat.
- 3) Mr. Jagdish Patel - Assistant Professor, Ganpat University.
- 4) Mrs. Minal Trivedi - Assistant Professor, Kadi Sci. College.
- 5) Mr. Payal Patel – M. G. Science Institute, Ahmadabad.
- 6) Mr. Pravin Dudhagara - S. G. University, Surat.
- 7) Bharat Patel, Macon Pharmaceutical at Own business
- 8) Mr. Rajesh Chaudhari, I/C principal, Adarsh College , Radhanpur
- 9) Mr. Tushar Patel, Manager, Navjivan seeds
- 10) Gaurang Thakkar, Asistant Consultant at Tata Consultancy Services

44. Give details of student enrichment programmes (special lectures / workshops / seminar) involving external experts.

-- Special Lectures are arranged inviting experts from other University to enrich our Students Department also organize Seminars/ Symposia a) Shops to benefit students

Scizone : Student seminar at every alternate Saturday

45. List the teaching methods adopted by the faculty for different programmes.

--

Conventional as well as use of audio visual aids are principal methods use

for classroom teaching.
E learning approach
Problem based learning

46. How does the department ensure that programme objectives are constantly met and learning outcomes are monitored?
:-- Learning out corner have formally not incorporated in the curriculum but the objectives are tried to achieve by routing clan Test/Seminars/Presentations /Assignments.
47. Highlight the participation of students and faculty in extension activities.
:--
Department regularly organizes health check-up Compulsory for university employees of the University in this Students of the Department & Staff are activity involved.
Students & Staff also take Part in Plantation Programme.
48. Give details of “beyond syllabus scholarly activities” of the department.
Life Science association: Department is having the Life Science association under which three student alliance is function (1) Environment, Health and safety (2) Discovery and Career (3) Sports and cultural
49. State whether the programme/ department is accredited/ graded by other agencies? If yes, give details. :-- Nil
50. Briefly highlight the contributions of the department in generating new knowledge, basic or applied.
:-- All Staff members have research projects which have societal applications, also these provide additional knowledge both basic and applied.
51. Detail five major Strengths, Weaknesses, Opportunities and Challenges (SWOC) of the department.
:--

Strength

- Good Infrastructural facility
- Regular intake of student
- Highly motivated staff members
- Computerized journal and use of e learning methodology
- Modern curriculum

Weakness

- Less number of teaching staff
- Less number of non-teaching staff
- Lake of research aptitude in students

Opportunity

- Opportunity to revise syllabus industry need
- Promotion of research culture
- Establishment of Industry Academia Interaction for mutual benefit
- Updating of instrumental set up

Challenges

- Maintain the teaching quality with less number of teaching and non-teaching
- Development of instruments and infrastructural facility to meet current need
- Get the UGC DSA and other scheme due to insufficient teaching staff

52. Future plans of the department.

- Permanent appointments for teaching non-teaching staff
- Updating of infrastructural and instrumental set up
- Industry academia interaction
- Start professional executive programme
- Get UGC DSA and other scheme for department development

Evaluative Report of the Department of Mathematics

1. Name of the Department : Mathematics
2. Year of establishment: 1993
3. Is the Department part of a School/Faculty of the university? YES
4. Names of programmes offered (UG, PG, M.Phil., Ph.D., Integrated Masters; Integrated Ph.D., D.Sc., D.Litt., etc.) :
PG - M.Sc. MATHEMATICS, Ph.D. – MATHEMATICS
5. Interdisciplinary programmes and departments involved : YES
6. Courses in collaboration with other universities, industries, foreign institutions, etc. : NIL
7. Details of programmes discontinued, if any, with reasons :
NIL
8. Examination System: Annual/Semester/Trimester/Choice Based Credit System :
UP TO MAY 2011 YEARLY AND FROM JUNE 2011 SEMESTER AND CBCS
9. Participation of the department in the courses offered by other departments: YES
10. Number of teaching posts sanctioned, filled and actual (Professors/Associate Professors/Asst. Professors/others)

	Sanctioned	Filled	Actual (including CAS & MPS)
Professor	01	01	CAS
Associate Professors	02	01	CAS
Asst. Professors	02	--	--
Others (Teaching Asst)	02	02	--

11. Faculty profile with name, qualification, designation, area of specialization, experience and research under guidance

Name	Qualification	Designation	Specialization	No. of Years of Experience	No. of Ph.D./M. Phil. students guided for the last 4 years
PROF. M.B. PRAJAPATI	M.Sc.,Ph.D., P.G.D.D.E	PROF.& HEAD	MATHEMATICAL MODELLING & GENERAL TOPOLOGY	28 YEARS	Four
Dr. A.V.KADIA	M.Sc., M.PHIL, Ph.D. (Ph.D. COMPLETED IN Feb-2013)	ASSO. PROF.	DYNAMICAL SYSTEM	25 YEARS	--

12. List of senior Visiting Fellows, adjunct faculty, emeritus professors : --
1. Prof. N.R.Ladhawala Rtd. Head & Prof. Mathematics Department, Gujarat University, Ahmedabad
 2. Prof. Vittahlbhai A.Patel Eme-Rits Prof. of mathematics Stat University Aarketa Californiya -95521
13. Percentage of classes taken by temporary faculty – programme-wise information :YEARLY 30%
14. Programme-wise Student Teacher Ratio 60 : 1
15. Number of academic support staff (technical) and administrative staff: sanctioned, filled and actual :ONE CLEARK,ONE TECHINCAL ASSITANT,ONE PEON
16. Research thrust areas as recognized by major funding agencies : --Nil
17. Number of faculty with ongoing projects from a) national b) international funding agencies and c) Total grants received. Give the names of the funding agencies, project title and grants received project-wise. : **NIL**
18. Inter-institutional collaborative projects and associated grants received : **NIL**
a) National collaboration b) International collaboration
19. Departmental projects funded by DST-FIST; UGC-SAP/CAS, DPE; DBT, ICSSR, AICTE, etc.; total grants received. : **NIL**

20. Research facility / centre with : **NIL**
- state recognition
 - national recognition
 - international recognition
21. Special research laboratories sponsored by / created by industry or corporate bodies : **NIL**
22. Publications:
- * Number of papers published in peer reviewed journals (national / international) : **THREE (NATIONAL)**
 - * Monographs : **NIL**
 - * Chapters in Books : **NIL**
 - * Edited Books : **NIL**
 - * Books with ISBN with details of publishers **NIL**
 - * Number listed in International Database (For *e.g.* Web of Science, Scopus, Humanities International Complete, Dare Database - International Social Sciences Directory, EBSCO host, etc.) **NIL**
 - * Citation Index – range / average : **NIL**
 - * SNIP : **NIL**
 - * SJR : **NIL**
 - * Impact Factor – range / average : --**NIL**
 - * h-index : -- **NIL**
23. Details of patents and income generated : **NIL**
24. Areas of consultancy and income generated : **NIL**
25. Faculty selected nationally / internationally to visit other laboratories / institutions / industries in India and abroad : **NIL**
26. Faculty serving in : **NIL**
- a) National committees b) International committees c) Editorial Boards d) any other (please specify)
27. Faculty recharging strategies (UGC, ASC, Refresher / orientation programs, workshops, training programs and similar programs). **WORK SHOPS , TRAINING PROGRAMME & SEMINARS**
28. Student projects
- percentage of students who have done in-house projects including inter-departmental projects : **100%(BEING PART OF CURRICULAM)**
 - percentage of students doing projects in collaboration with other

universities / industry / institute

29. Awards / recognitions received at the national and international level by :

NIL

- Faculty
- Doctoral / post doctoral fellows
- Students

30. Seminars/ Conferences/Workshops organized and the source of funding (national / international) with details of outstanding participants, if any. :-

-

31. Code of ethics for research followed by the departments : AS PER UNIVERSITY NORMS

32. Student profile programme-wise:

Name of the Programme (refer to question no. 4)	Applications received	Selected		Pass percentage	
		Male	Female	Male	Female
JUNE-2010	39	3	9	3	9
JUNE-2011	58	3	23	3	22
JUNE-2012	149	16	40	12	26
JUNE-2013	198	9	34		
		Admitted(60)			
		Admitted(60)			

33. Diversity of students

Name of the Programme (refer to question no. 4)	% of students from the same university	% of students from other universities within the State	% of students from universities outside the State	% of students from other countries
M.Sc., Ph.D. (AY:2010)	95%	5%	NIL	NIL
M.Sc. , Ph.D. (AY:2011)	95%	5%	NIL	NIL
M.Sc. , Ph.D. (AY:2012)	95%	5%	NIL	NIL
M.Sc. , Ph.D. (AY:2013)	95%	5%	NIL	NIL

34. How many students have cleared Civil Services and Defence Services

examinations, NET, SET, GATE and other competitive examinations?
Give details category-wise.

NET EXAM PASSED:YEAR 2009 TWO ,YEAR 2010 FOUR, YEAR 2011 ONE, YEAR 2012 NIL, YEAR 2013 ONE STUDENT

GPSC Class I & II : Seven (Designated as Assistant Professor in the Govt. Engineering Colleges)

35. Student progression

Student Progression	Percentage against enrolled
UG to PG	--
PG to M.Phil.	--
PG to Ph.D.	--
Ph.D. to Post-Doctoral	--
Employed	100%
• Campus Selection	None
• Other than campus recruitment	100%
Entrepreneurs	--

36. Diversity of staff

Percentage of faculty who are graduates	
of the same university	0%
from other universities within the State	100%
from universities from other States	0%
from universities outside the country	0%

37. Number of faculty who were awarded M.Phil., Ph.D., D.Sc. and D.Litt. during the assessment period : **ONE**

38. Present details of departmental infrastructural facilities with regard to

- Library : Central Library
- Internet facilities for staff and students : YES
- Total number of class rooms :THREE
- Class rooms with ICT facility: ONE COMPUTER LAB
- Students' laboratories :ONE
- Research laboratories : ONE

39. List of doctoral, post-doctoral students and Research Associates

- from the host institution/university :NIL
- from other institutions/universities : NIL

40. Number of post graduate students getting financial assistance from the university. : NIL

41. Was any need assessment exercise undertaken before the development of new programme(s)? If so, highlight the methodology.:YES, STAFF AND INFRASTRUCTURE
42. Does the department obtain feedback from
 - a. faculty on curriculum as well as teaching-learning-evaluation? If yes, how does the department utilize the feedback? YES
 - b. students on staff, curriculum and teaching-learning-evaluation and how does the department utilize the feedback? YES
 - c. alumni and employers on the programmes offered and how does the department utilize the feedback? NIL
43. List the distinguished alumni of the department (maximum 10) :NIL
44. Give details of student enrichment programmes (special lectures / workshops / seminar) involving external experts. STUDENTS ARE MOTIVATED BY SUCH TYPES OF ACTIVITIES .
45. List the teaching methods adopted by the faculty for different programmes. USING COMPUTER & MMP
46. How does the department ensure that programme objectives are constantly met and learning outcomes are monitored? TEACHING,LEARNING & EVALUATION METHOD
47. Highlight the participation of students and faculty in extension activities. STUDENTS AND FACULTY INVOLVED EACH & EVERY ACTIVITY RUN BY /ORGANIZED BY DEPARTMENT/UNIVERSITY.
48. Give details of “beyond syllabus scholarly activities” of the department. SEMINAR & PROJECT ACTIVITY In every year for the benefits and motivations of the students we are assigning Assignment/Term Work and conducting Seminars , Problem Solving, Unit/Internal/Oral Test. We have implemented a continuous evaluation process from Last year for internal process.
49. State whether the programme/ department is accredited/ graded by other agencies? If yes, give details. NIL
50. Briefly highlight the contributions of the department in generating new knowledge, basic or applied. CONTRIBUTING OTHER ACEDMIC & NON ACEDMIC SECTORS BY OUR PASS OUT DEPARTMENT STUDENTS.(IF THEY ARE WORKING IN THE SECTOR) Presently, we teach and emphasize student’s creativity, excellence, integrity through

course work, extracurricular activities, advising and counseling, academic process and reach-as-we-practice.

51. Detail five major Strengths, Weaknesses, Opportunities and Challenges (SWOC) of the department.

Strengths:

- ❖ Highly qualified and experienced permanent teaching staff
- ❖ Hostel accommodation within institution's campus for Boys and Girls.
- ❖ Well developed labs having latest facilities

Weaknesses:

- ❖ Scarcity of teaching staff
- ❖ Less involvement of institute in research activities due to overburden in academic and administration work
- ❖ No formal alumni association

Opportunities:

- ❖ To enrich Library for academic and research use by students
- ❖ Student support mechanism for competitive exams
- ❖ Academic leadership program
- ❖ Development of research aptitude among students

Challenges:

- ❖ Serious lack of faculties on sanctioned posts
- ❖ Implementation of CBCS curriculum in true sense due to lack of faculties

52. Future plans of the department.

- Organize workshop on Problem solving campaign for the NET/SLET in the department.
- Use the ICT class room for Teaching and discussion sessions and/or Smart Interactive White Board.
- Develop the research in current sciences.

Evaluative Report of the Department of Sanskrit and Bhartiya Vidya

1. Name of the Department - Department of Sanskrit & Bhartiya Vidya
2. Year of establishment - 1992
3. Is the Department part of a School/Faculty of the university? - 3
4. Names of programmes offered (UG, PG, M.Phil., Ph.D., Integrated Masters; Integrated Ph.D., D.Sc., D.Litt., etc.)
- M.A., M.Phil, Ph.D.
5. Interdisciplinary programmes and departments involved
- Computer, Prakrit
6. Courses in collaboration with other universities, industries, foreign institutions, etc.
- Nil
7. Details of programmes discontinued, if any, with reasons
- Nil
8. Examination System: Annual/Semester/Trimester/Choice Based Credit System
- Semester/Choice Based Credit System
9. Participation of the department in the courses offered by other departments
- Jainology
10. Number of teaching posts sanctioned, filled and actual
(Professors/Associate Professors/Asst. Professors/others)

	Sanctioned	Filled	Actual (including CAS & MPS)
Professor	1	1	
Associate Professors	2	1	
Assistant Professor	2	1	
Teaching Assistant	1	1	

Faculty profile with name, qualification, designation, area of specialization, experience and research under guidance

Name	Qualification	Designation	Specialization	No. of years of experience	No. of Ph.D./M.Phil. students guided for the last 4 years
Prof.D.B. Rathva	M.A., Ph.D.	Prof. & Head	Vedant	20	M.Phil- 20 Ph.D. - 9
Dr.D.C. Patel	M.A.,M.Phil., Ph.D	CAS Prof.	Dharmashatra	14	M.Phil- 20 Ph.D. - 4
Dr.S.A. Thakkar	M.A., Ph.D.	Assi.Prof.	Prakrit (Jainology)	39	---

12. List of senior Visiting Fellows, adjunct faculty, emeritus professors
- Dr. A. I. Thakor, Former Professor & Head, Department of Sanskrit, Sardar Patel University, Vallabh Vidhyanagar
 - Dr. Dinanath Sharma, Associate Professor, Department of Prakrit, Gujarat University, Ahmedabad

13. Percentage of classes taken by temporary faculty – programme-wise information
- M.A. - 48.80
 - M.Phil - 33.33

14. Programme-wise Student Teacher Ratio -

15. Number of academic support staff (technical) and administrative staff: sanctioned, filled and actual -

	Sanctioned	Filled	Actual (including CAS & MPS)
Clerk	1	1	
Peon	1	-	

16. Research thrust areas as recognized by major funding agencies-
Indology Science, Archaeology, Manuscript logy

17. Number of faculty with ongoing projects from
- | | | |
|-----------------------------------|---|----------------|
| a) national | - | 02 |
| b) international funding agencies | - | --- |
| c) Total grants received. | - | Rs. 2,15,000/- |
- Give the names of the funding agencies, project title and grants received project-wise.
- (i) **Principal Investigator : Dr.Dilip C.Patel**
Title of the Project : “Data mining from Sanskrit literature and its relevance with current scientific information for metal technology
Amount: 85,000/- Rs.
Funding Agency: UGC, New Delhi
- (ii) **Principal Investigator : Dr.D. B. Rathava**
Title of the Project : Patan Jain Gyan Bhandar : Importance, Limitations and Solutions
Amount: 1,30,000/- Rs.
Funding Agency: UGC, New Delhi
18. Inter-institutional collaborative projects and associated grants received
- | | |
|--|--------------------------------|
| a) National collaboration | b) International collaboration |
| a) National collaboration with Association of Indian Universities, (AIU) grant for research workshop | |
19. Departmental projects funded by DST-FIST; UGC-SAP/CAS, DPE; DBT, ICSSR, AICTE, etc.; total grants received. - Nil
20. Research facility / centre with
- state recognition
 - national recognition
 - international recognition
- National recognition
- International recognition
21. Special research laboratories sponsored by / created by industry or corporate bodies - Yes
Five lakhs sanction for Research Fellowship from corporate body.
(Jitendrabhai Gandhi)
22. Publications:
- * Number of papers published in peer reviewed journals
- | | | |
|----------|---|----|
| National | - | 23 |
|----------|---|----|

- International - 01
Total - 24
- Monographs - No
 - Chapters in Books - 01
 - Edited Books 02
 - Books with ISBN with details of publishers - No
 - Number listed in International Database(For *e.g.* Web of Science, Scopus, Humanities International Complete, Dare Database - International Social Sciences Directory, EBSCO host, etc.) No
 - Citation Index – range / average No
 - SNIP No
 - SJR - No
 - Impact Factor – range / average - No
 - h-index - No
23. Details of patents and income generated - No
24. Areas of consultancy and income generated - No
- / Faculty selected nationally / internationally to visit other laboratories / institutions industries in India and abroad - No
25. Faculty serving in
- a) National committees -- No
 - b) International committees -- No
 - c) Editorial Boards -- Yes
 - (i) International Multidisciplinary Peer Reviewed Research Journal "SOHAM" (Prof. Dilip C. Patel)
 - (ii) International Multidisciplinary Peer Reviewed Research Journal "ATMAY" (Prof. D. B. Rathava)
 - (iii) National Research Journal – Haim Prapa
 - (iv) State Research Journal - Nishtha
 - d) any other (please specify) - No
27. Faculty recharging strategies (UGC, ASC, Refresher / orientation programs, workshops, training programs and similar programs). Yes
- (i) Short term course on Human Development organised by ASC, Shimla attended by Prof. Dilip C. Patel
 - (ii) ICT training programme organized by Microsoft under SAKSHAM scheme at HNGU, Patan attended by Prof. D. B. Rathava

28. Student projects

- percentage of students who have done in-house projects including inter-departmental projects – 100%
- percentage of students doing projects in collaboration with other universities / industry / institute - Nil

29. Awards / recognitions received at the national and international level by -

- Faculty -- No
- Doctoral (Ph.D.) -- 2
- Students (M. Phil) - 6

30. Seminars/ Conferences/Workshops organized and the source of funding (national/international) with details of outstanding participants

Event	Date	No. of Participant
Research Initiative-I Workshop	21th October, 2010	46
Research Initiative-II Workshop	10 th to 12 th January,2011	66
Research Initiative-III Workshop	05 th July, 2011	35
Sadbhavana Samaroh	29 th to 30 th January, 2011	236
“Research Methodology : A March Towards Creating Research Culture	21 st to 24 th November, 2011	27
Hemchandracharya Samaroh-2011	25 th to 27 th February, 2011	102
Hemchandracharya Samaroh-2012	14 th to 16 th February, 2012	167
Hemchandracharya Samaroh-2013	15 th to 17 th March, 2013	157
Young Social Scientist Workshop	26 th to 27 th September, 2011	135

31. Code of ethics for research followed by the departments - Yes

32. Student profile programme-wise: -

M. A.

Year	Applications received	Selected		Pass percentage	
		Male	Female	Male	Female
2009-10	75	42	33	34	22
2010-11	89	33	56	33	45

2011-12	86	24	62	20	58
2012-13	151	46	105	41	98
2013-14	104	32	72	30	68

M. Phil.

Year	Applications received	Selected		Pass percentage	
		Male	Female	Male	Female
2009-10	20	14	6	14	6
2010-11	16	11	6	10	6
2011-12	17	6	11	6	11
2012-13	30	18	12	18	12
2013-14	19	8	11	6	10

33. Diversity of Students

M. A.

Year	% of students from the same university	% of students from the other universities within the state	% of students from universities outside the state	% of students from other countries
2009-10	75	0	-	-
2010-11	88	1	-	-
2011-12	85	1	-	-
2012-13	150	1	-	-
2013-14	104	0	-	-

M. Phil.

Year	% of students from the same university	% of students from the other universities within the state	% of students from universities outside the state	% of students from other countries
2009-10	19	1	-	-
2010-11	16	2	-	-

2011-12	16	1	-	-
2012-13	25	5	-	-
2013-14	17	2	-	-

34. How many students have cleared Civil Services and Defense Services examinations, NET, SET, GATE and other competitive examinations? Give details category-wise.

List of Students (Cleared NET Exam)

1. Nanubha Vaghela
2. Soni Bhavanaben Gisubhai
3. Rabari Balabhai Sargambhai

List of Students (Cleared JRF-NET Exam)

1. Rabari Balabhai Sargambhai

List of Students (Cleared GSLET Exam)

1. Sasun Velabhai Tejabhai
2. Parmar Jashuben Mangabhai
3. Kansara Niravkumar Rasiklal
4. Bare Maneshbhai Dadubhai
5. Chauhan Chandrikaben Devjibhai
6. Raval Alpeshkumar Mathurbhai
7. Makwana Manharbhai Amrutbhai
8. Rathava Rumaliben Malsing
9. Raval Pankajkumar Rasikbhai
10. Rabari Balabhai Sargambhai

35. Student progression

Student progression	Percentage against enrolled
UG to PG	NA
PG to M.Phil.	25.33
PG to Ph.D.	2
Ph.D. to Post-Doctoral	--
Employed	

<input type="checkbox"/> Campus selection	---
<input type="checkbox"/> Other than campus recruitment	32%
Entrepreneurs	9%

36. Diversity of staff - Yes

Percentage of faculty who are graduates

of the same university	50%
from other universities within the State –	50%
from universities from other States -	Nil
from universities outside the country -	Nil

37. Number of faculty who were awarded M.Phil., Ph.D., D.Sc. and D.Litt. during the assessment period - Two

38. Present details of departmental infrastructural facilities with regard to

- a) Library - Departmental & Central Library
- b) Internet facilities for staff and students - Yes
- c) Total number of class rooms - 6
- d) Class rooms with ICT facility - Two
- e) Students' lab - One
- f) Research Room - Two

39. List of doctoral, post-doctoral students and Research Associates

- a) from the host institution/university -
 - (i) Deliya Sudhir Mulchandbhai
 - (ii) Patel Priyanka Amrutbhai
 - (iii) Rathava Rumaliben Devsinhbhai
 - (iv) Majirana Vinod
 - (v) Patel Pooja Narottambhai

b) from other institutions/universities - Nil

40. Number of post graduate students getting financial assistance from the university.

Sr. No.	YEAR	OBC	SC	ST
1	2010 - 11	30	6	2
2	2011 - 12	32	19	4
3	2012 - 13	64	18	10
4	2013 - 14	53	9	12
5	2014 - 15	33	11	15

Note :-Research Fellowship by Corporate Body

41. Was any need assessment exercise undertaken before the development of new programme(s)? If so, highlight the methodology. – Nil
42. Does the department obtain feedback from
- faculty on curriculum as well as teaching-learning-evaluation? yes, how does the department utilize the feedback?
 - students on staff, curriculum and teaching-learning-evaluation ? Yes how does the department utilize the feedback?
 - Alumni and employers on the programmes offered ? Yes how does the department utilize the feedback?
43. List the distinguished alumni of the department (maximum 10)

Sr. No.	Student Name
1	Prof. Dilip C. Patel
2	Dr. Balabhai Rabari
3	Bhavnaben Soni
4	Nanubha Vaghela
5	Manjulaben Parmar
6	Velajibhai Sasun
7	Bhailal Patel
8	Rubaliben Rathva
9	Hiteshbhai Thakkar
10	Kalpnaben Parmar
11	Dr. Brijeshkumar Dave

44. Give details of student enrichment programmes (special lectures / workshops / seminar) involving external experts. – Yes
Manibhai Vyakhyan Mala
Sanskrit Sambhasan Shibir
45. List the teaching methods adopted by the faculty for different programmes. -
Yes
Lecture Method
Seminar Method
Presentation Method (By ICT)
Eminent Lecture by Video Clips

46. How does the department ensure that programme objectives are constantly met and learning outcomes are monitored? - Yes
It is monitored by Internal Exam, Seminars, Debat and feedback from the students.
47. Highlight the participation of students and faculty in extension activities. – Yes
Faculty and Students involve in different workshop, seminar and conference like Hemchandracharya Samaroh, Internation Conference like Silver Jubilee Function and other research workshop.
48. Give details of “beyond syllabus scholarly activities” of the department.
Visit to the Jain Gyan Bhandar for develop the knowledge of ancient manuscript.
MoU with other colleges for knowledge development of the students through faculty exchange programme by mutually undetstanding.
49. State whether the programme/ department is accredited/ graded by other agencies?
NA
50. Briefly highlight the contributions of the department in generating new knowledge, basic or applied.
(i) Develop documentary of Indian & Abroad Sanskrit related Post Ticket.
(ii) Under the Historical Research, Department create documentary note of step well of North Gujarat region.
51. Detail five major Strengths, Weaknesses, Opportunities and Challenges (SWOC) of the department.
Strengths
- We are getting over valued response in number of admission to the available seats.
 - Every year organize national seminar & publish national research journal “Haim Prapa”.
 - Department generate corporate fellowship for the research students.
 - Department have advanced IT facilities and infrastructure facilities are available.
 - Faculties are involve in the social responsibility as well as development of university.

Weakness

- Department has lack of staff.
- Department can't give the more choice in Sanskrit.
- Language Lab is not available for Sanskrit Development
- Department is situated very far from transport facility.

Opportunity

- Wide scope in social & scientific research.
- Skill development courses can be start like Jyotish, Vastushashtra etc.
- Short term courses for manuscript reading in various lipi.
- Develop research center for medicinal plant ; organize short term course for its awareness and develop medicine.
- Develop Indian Knowledge study center.

Challenge

- Year by year number of students are decreases.
- Government are not sanction post of faculty.
- Empower the student for compete at national level exam.
- Provide placement to the students.
- Collaboration is very difficult and it should be inter disciplinary.

52. Future plans of the department.

Department is planning to develop the Study Centre of India Knowledge System, Advance study centre for excellence in social science research and study centre for medicinal plant for creating awareness of medicinal plant among the local people and develop medicine from the help of pharmacy students and establish medical provision store for selling in the university campus.

Department of Biotechnology

1. Name of the Department : Department of Biotechnology
2. Year of establishment : 2004-2005
3. Is the Department part of a School/Faculty of the university:
Yes, Science Faculty
4. Names of programmes offered (UG, PG, M.Phil., Ph.D., Integrated Masters; Integrated Ph. D., D. Sc., D. Litt., etc.):
PG, M.Phil. and Ph.D.
5. Interdisciplinary programmes and departments involved:
Not Applicable
6. Courses in collaboration with other universities, industries, foreign institutions, etc.
M.Phil. in Biotechnology in collaboration with Gujarat State Biotechnology Mission (GSBTM), Gandhinagar
7. Details of programmer discontinued, if any, with reasons:
No programme being discontinued
8. Examination System: Annual/Semester/Trimester/Choice Based Credit System:
Semester exam in CBCS system
9. Participation of the department in the courses offered by other departments
Not Applicable
10. Number of teaching posts sanctioned, filled and actual (Professors/ Associate Professors/ Asst. Professors/others).

	Sanctioned	Filled	Actual including CAS and MPS
Professor	-	-	-
Associate Professor	-	-	-
Assistant Professor	03	03	03
Other			

11. Faculty profile with name, qualification, designation, area of specialization, experience and research under guidance

Name	Qualification	Designation	Specialization	No. of Years of Experience	No. of Ph.D./M.Phil. students guided for the last 4 years
Dr. Sanjay M. Dave	M. Sc., Ph.D.	Coordinator & Assistant Professor	Zoology	09	06 Guided & 02 continue (M.Phil.) 06 continue (Ph.D.)
Dr. Ashish D. Patel	M. Sc., Ph.D.	Assistant Professor	Botany	07	05 Guided & 03 continue (M.Phil.) 06 continue (Ph.D.)
Dr. Himanshu S. Bariya	M. Sc., Ph.D.	Assistant Professor	Biochemistry	04	05 Guided & 02 continue (M.Phil.)

12. List of senior Visiting Fellows, adjunct faculty, emeritus professors

1. Dr. Hari Misra, Bhabha Atomic Research Center, Mumbai
2. Dr. B.S. Chandel, Professor, SDAU, Dantiwada
3. Dr. H.C. Chauhan, Associate Professor, SDAU, Dantiwada
4. Dr. Himanshu Patel, Director, Stem Cure, Ahmedabad
5. Dr. N. K. Jain, Professor, Gujarat University, Ahmedabad

13. Percentage of classes taken by temporary faculty – programme-wise information

10% of classes taken by temporary faculty

14. Programme-wise Student Teacher Ratio

- M. Sc.: 7:1

- M. Phil: 2:1
- Ph.D.: 6:1

15. Number of academic support staff (technical) and administrative staff: sanctioned, filled and actual

Present administrative staff is 02 (01 clerk and 01 Peon)

16. Research thrust areas as recognized by major funding agencies

Animal Genetics, Plant Pathogen Interactions, Plant Biotechnology, Proteomics, DNA barcoding and Molecular biology

17. Number of faculty with ongoing projects from a) national b) international funding agencies and c) Total grants received. Give the names of the funding agencies, project title and grants received project-wise.

- Ongoing Projects: 07

Major research grants received				
DEPARTMENT OF BIOTEHCNOLOGY, HNGU, PATAN				
Sr. No.	Name	Project	Completed/ ongoing	Grant in Rs.
1	Dr. Sanjay M. Dave	Occurrence, distribution and status of small and certain rare species of mammals in the North Gujarat region funded by Gujarat Forest Research Institute, Gandhinagar	Completed (Co-PI)	660000/-
		Identification of enteric pathogens from wild bird population funded by Gujarat Council on Science & Technology, (GUJCOST), Gandhinagar	Completed (PI)	18400/-
		Identification and characterization of enteric bacteria in wild bird species funded by Gujarat State Biotechnology Mission	Completed (PI)	1057300/-

		(GSBTM), Gandhinagar		
		Developing and testing of Soil / invertebrate interaction Funded by University Grant Commission (UGC), New Delhi	Ongoing (PI)	256000/-
2	Dr. Ashish D. Patel	Metaproteomic analysis of different protein response to soil salinity funded by University Grant Commission (UGC), New Delhi	Ongoing (PI)	1438300/-
		Monitoring and evaluating the nutritional health status and morbidity of school going children and initiating nutrition health education programme funded by Department of Science and Technology (DST), New Delhi (WOS-A Scheme)	Ongoing (PI)	1224000/-
		Influence of Arid and semi-arid microbial composition on growth, water status and nutrient uptake mechanism in certain bio-indicator plants of North Gujarat region funded by Gujarat State Biotechnology Mission (GSBTM), Gandhinagar	Ongoing (PI)	1900600/-
3	Dr. Himanshu Bariya	INSPIRE CAMP UGC-BSR Start Up grant for newly recruited faculty at Assistant professor level in science department funded by University Grant Commission (UGC), New	Conti... Ongoing (PI)	48,75,000 600000/-

	Delhi		
	Characterization of fungal elicitors and their role in expression of resistance genes in <i>Arachis hypogaea</i> L. funded by Science and Engineering Research Board, DST, New Delhi	Ongoing (PI)	1085000/-
	Fungal DNA Barcoding sponsored by Gujarat State Biotechnology Mission (GSBTM), Gandhinagar	Ongoing (PI)	1950000/-
Total Grant received			15064600/-

18. Inter-institutional collaborative projects and associated grants received
a) National collaboration b) International collaboration
- National Collaboration: Department has collaboration with GSBTM, Gandhinagar, Gujarat. 48 lakhs Rs.
19. Departmental projects funded by DST-FIST; UGC-SAP/CAS, DPE; DBT, ICSSR, AICTE, etc.; total grants received.
Not yet
20. Research facility / centre with
- State recognition : GSBTM, Gandhinagar
 - National recognition : Nil
 - International recognition : Bio-NUT & University of Groningen, Netherlands
21. Special research laboratories sponsored by / created by industry or corporate bodies
- No any
22. Publications:
- * Number of papers published in peer reviewed journals (national / international) : National: 21; International: 18
 - * Monographs
 - * Chapters in Books: 03 (International)
 - * Edited Books
 - * Books with ISBN with details of publishers : 01 (VDM Verlag Dr. Muller, Germany)
 - * Number listed in International Database (For e.g. Web of Science, Scopus, Humanities International Complete, Dare Database - International Social Sciences Directory, EBSCO host, etc.)

- * Citation Index – range / average
- * SNIP
- * SJR
- * Impact Factor – range / average : Total IF: 17.34
- * h-index: 09

Name, designation, field of specialization & research publication		
1	Name	Dr. Sanjay M. Dave
	Designation	Assistant Professor and Coordinator
	Field of Specialization	Animal genetics, Wild life genetic, animal biotechnology, Biostatistics
	Research Publication	<p>I. Bhalodia, K., Dave, S.M. and Soni, V.C. 2001. Herpetofauna of Rampara Wildlife Sanctuary, Gujarat. Cobra 45: 5 -12</p> <p>II. Bhalodia, K., Bhuva, V.J., Dave, S.M. and Soni, V.C. 2001. Fresh water Molluscs in Barda Wildlife Sanctuary, Gujarat. Zoos' Print 16 (9): 591.</p> <p>III. Soni, V.C., Bhalodia, K.P., Dave, S.M. and Bhuva, V.J. 2002. Molluscan Fauna and its Distribution in the Wild Ass Sanctuary. J. Bombay Nat. Hist. Soc. 99(1): 139 – 141.</p> <p>IV. Bhalodia, K., Bhuva, V.J., Dave, S.M. and Soni, V.C. 2002. Butterflies of Vansda National Park, Gujarat. Zoos' Print. 17(10): 903 – 904.</p> <p>V. Bhalodia, K., Bhuva, V.J., Dave, S.M. and Soni, V.C. 2002. Butterflies of Ratanmahal Wildlife Sanctuary, Gujarat. Zoos' Print. 17(10): 905 – 906.</p> <p>VI. Bhalodia, K., Dave, S.M. and Soni, V.C. 2002. Butterflies of Narayan Sarovar Wildlife Sanctuary, Gujarat. Zoos' Print. 17(10): 906 – 907.</p> <p>VII. Bhalodia, K., Bhuva, V.J., Dave, S.M. and Soni, V.C. 2002. Herpetofauna of Barda Wildlife Sanctuary, Gujarat. Cobra. 47: 8 – 16.</p> <p>VIII. Soni, V.C., Sharma, P., Dave, S.M., Bhalodia, K. and Vijaykumar, V. (2004). Nesting Ecology of some terrestrial birds in Rajkot</p>

		<p>city (Gujarat). Journal of Current Biosciences. 2(1): 97-104.</p> <p>IX. Dave, S.M., Soni, V.C. and Bhalodia, K. 2002. Effect of Water Level on Piscivorous Birds. Presented in 3rd National Symposium on "Avian Biodiversity - Issues and conservation strategies" held at Acharya N.G. Ranga Agricultural University, Hyderabad. (Full paper has been sent for publication)</p> <p>X. Kundu, Rahul; Dolly Patel; Dave, Sanjay; Roy, Avijit; Vadagama, Rupa; Devani, Mukesh; Pandya, Swati; Mishra, Sudipta; Patel, Nilesh and Kumar, K. Sambath. (2002). Influence of short term chromium (VI) toxicity and subsequent withdrawal of toxic stress to some membrane bound enzymes in mice. Adv. Pharmacol. Toxicol. Vol. 3(1) 2002: 47-62.</p> <p>XI. Dave, S.M., Bhalodia, Ketan and Soni, V.C. (2007). Foraging Ecology of wading birds in a drying manmade wetland of semi arid area, Gujarat. Journal of Environmental Research and Development.</p> <p>XII. Gajera, N., Dave, S.M. and Dharaiya, N.A. (2009). Nesting pattern of some terrestrial birds in Danta Forest Range, northern Gujarat, India. Journal of Threatened Taxa 1(3): 170-173.</p> <p>XIII. Nikunj Gajera, S.M. Dave and Nishith Dharaiya. 2009. Feeding pattern and den ecology of Striped hyena. Tigerpaper 36(1): 13-17</p> <p>XIV. Dave, S.M. (2011). Isolation and Identification of Bacteria Originating from a Larvivorous fish, <i>Aphanius dispar</i>. Life sciences Leaflets 19: 823-829.</p> <p>XV. Dave, S.M. (2011). Prevalence of Rotavirus and Adenovirus in wild Blue Rock Pigeon.</p>
--	--	--

			<p>Life sciences Leaflets 19: 830-835.</p> <p>XVI. Dave, S.M. (2011). Comparison of <i>E. coli</i> and Campylobacter Genome. Life sciences Leaflets 19: 836-841.</p> <p>XVII. Prepared E-Manual of Computers for Life Sciences for Master syllabus Computer & Bioinformatics topic of all the Life Sciences and allied applied science subjects' syllabus and UGC-NET examination.</p>
2	Name	:	Dr. Ashish D. Patel
	Designation	:	Assistant Professor
	Field of Specialization	:	Proteomics, Plant stress biology, Plant Biotechnology
	Research Publication	:	<p>I. Hirpara KD, Ramoliya PJ, Patel AD, Pandey AN. 2005. Effect of salinisation of soil on growth and macro- and micro-nutrient accumulation in seedlings of <i>Butea monosperma</i> (Fabaceae). <i>Anales De Biologia</i>. 27: 3-14.</p> <p>II. Patel AD, Pandey AN. 2007. Effect of soil salinity on growth, water status and nutrient accumulation in seedlings of <i>Cassia montana</i> (Fabaceae). <i>Journal of Arid Environment</i>. 70: 174-182.</p> <p>III. Patel AD, Pandey AN. 2008. Effect of salinisation of soil on growth, water status and nutrient accumulation in seedlings of <i>Holoptelea integrifolia</i> (Ulmaceae). <i>Plant, Soil and Environment</i> 54(9): 367-373.</p> <p>IV. Vaghela PM, Patel AD, Bhatti PM, Pandey AN. 2008. Implications of calcium nutrition on the response of <i>Butea monosperma</i> (Fabaceae) to soil salinity. <i>Arid Land Research and management</i> 23: 311-326.</p> <p>V. Bhatt MJ, Patel AD, Bhatti PM, Pandey AN. 2008. Effect of salinisation of soil on growth, water status and nutrient accumulation in seedlings of <i>Ziziphus</i></p>

		<p><i>mauritiana</i> (Rhamnaceae). Journal of Fruit and Ornamental Plant Research 16: 383-401.</p> <p>VI. Patel AD, Pandey AN. 2009. Effect of salinisation of soil on growth, water status and nutrient accumulation in seedlings of <i>Delonix regia</i> (Fabaceae). Acta Ecologica Sinica 29: 109-115.</p> <p>VII. Patel AD, Pandey AN. 2010. Effect of salinisation of soil on growth, water status and nutrient accumulation in seedlings of <i>Acacia auriculiformis</i> (Fabaceae). Journal of Plant Nutrition. 33: 914-932.</p> <p>VIII. Patel AD, Pandey AN. 2010. Effect of salinisation of soil on growth, water status and nutrient accumulation in seedlings of <i>Jatropha curcas</i> (Euphorbiaceae). Anales De Biologia. 32: 59-71.</p> <p>IX. Vaghela PM, Patel AD, Pandey IB, Pandey AN. 2010. Implications of Calcium nutrition on the response of <i>Salvadora persica</i> (Salvadoraceae) to soil salinity. Communications in Soil Science and Plant Analysis 41: 2644-2660.</p> <p>X. Patel NT, Vaghela PM, Patel AD, Pandey AN. 2011. Implications of calcium nutrition on the response of <i>Caesalpinia crista</i> (Fabaceae) to soil salinity. Acta Ecologica Sinica 31: 24-30.</p> <p>XI. International Book chapter 2013: Ashish Dahyabhai Patel, Kishor Lalcheta, Sarvajeet Singh Gill, Narendra Tuteja, Salinity Tolerance of <i>Avicennia officinalis</i> L. (Acanthaceae) from Gujarat Coasts of India. In: Climate Change and Abiotic Stress Tolerance. Editors: Narendra Tuteja and Sarvajeet S. Gill, Publisher: Wiley, Germany.</p> <p>XII. Himanshu Bariya, Snehal Bagatharia, Ashish</p>
--	--	--

			Patel (2014) Boron: A promising nutrient for increasing growth and yield of plants. In Nutrient Use Efficiency: Concept and Approach. Springer (<i>In press</i>).
3	Name	:	Dr. Himanshu S. Bariya
	Designation	:	Assistant Professor
	Field of Specialization	:	Plant-Pathogen Interactions, Biochemistry & Molecular Biology
	Research Publication	:	<p>I. Himanshu Bariya and Vasudev Thakkar. Biochemical and molecular determinance of resistance and susceptibility in <i>Solanum tuberosum</i> (potato) plants challenged with <i>Phytophthora infestans</i>. <i>Archives of Phytopathology and Plant protection</i>, 45:12, 1429-1438</p> <p>II. M N Patel, M R Chhasatia, H S Bariya, Vasudev Thakkar. DNA cleavage, binding and intercalation studies of drug-based oxovanadium (IV) complexes. <i>Journal of Enzyme Inhibition and Medicinal Chemistry</i> 2009; 24 (3): 715-721.</p> <p>III. A L Singh, R S Jat, Vidya Chaudhari, Himanshu Bariya, Seema Sharma. Toxicities and Tolerance of Mineral Elements Boron, Cobalt, Molybdenum and Nickel in Crop Plants. <i>Plant Stress</i>, 2010, 4(2): 31-56.</p> <p>IV. M N Patel, M R Chhasatia, H S Bariya, Vasudev Thakkar. Synthesis, characterization and biological studies of some homodinuclear complexes of zinc with second-generation quinolone drug and neutral bidentate ligands. <i>Polyhedron</i> 2010, 29: 1918-1924.</p> <p>V. Himanshu Bariya, Vasudev Thakkar, Amit Thakkar, R B Subramanian. Induced Systemic Resistance in different varieties of <i>Solanum tuberosum</i> by pure and crude</p>

		<p>elicitor treatment. <i>Indian Journal of Experimental Biology</i>, 2011, 49: 151-162.</p> <p>VI. Himanshu Bariya and Vasudev Thakkar. Phenols and peroxidase isozymes act as biochemical markers for resistance against late blight of potato. <i>International Journal of Biology, Pharmacy and Allied Sciences</i>, 2012, 1(3): 306-321.</p> <p>VII. Amit Thakkar, Vasudev Thakkar and Himanshu Bariya. Extraction, Separation and Quantification of NPR1 in <i>Solanum tuberosum</i>. <i>Journal of cell and Tissue Research</i> 2009; 9 (1): 1709-1716.</p> <p>VIII. Nikul Dave, Krima Prajapati, Zinal Patel, Aarti Patel and Himanshu Bariya. <i>Trichoderma harzianum</i> elicits defense response in <i>Brassica juncea</i> plantlets. <i>International Research Journals of Biological Sciences</i>, 2013; 2(11), 1-10.</p> <p>IX. Nandini D and Bariya H, Induction of systemic acquired resistance in <i>Arachis hypogaea</i> L. By <i>Aspergillus flavus</i> derived elicitors. <i>Journal of cell and tissue research</i>, 2014; 14(2) 4395-4403.</p> <p>X. Himanshu Bariya, Snehal Bagatharia, Ashish Patel (2014). Boron: A promising nutrient for increasing growth and yield of plants. In <i>Nutrient Use Efficiency: Concept and Approach</i>. Springer- 2014 (<i>In press</i>).</p> <p>XI. Himanshu Bariya, Amrit Lal Singh, Vidya Chaudhari. Measurement of Fe(II) and Fe(III) in Groundnut by in-column and post column reactions in ion-chromatography. <i>Communication in soil science and plant analysis (In press)</i></p>
--	--	--

23. Details of patents and income generated

N.A.

24. Areas of consultancy and income generated
N.A.
25. Faculty selected nationally / internationally to visit other laboratories / institutions / industries in India and abroad
02 faculties were selected for Research at International research Institutes. (USA, The Netherlands, and UK)
26. Faculty serving in
a) National committees b) International committees c) Editorial Boards d) any other (please specify)
- Dr. Himanshu Bariya, Editorial Board, World Research Journal of Tropical Agriculture, Bio-info Publication, UK
 - Dr. Himanshu Bariya; Life Member, Indian Science Congress Association. Kolkata, India. Membership No. L24669
27. Faculty recharging strategies (UGC, ASC, Refresher / orientation programs, workshops, training programs and similar programs).
- Faculties regularly attend and participate in ASC Refresher courses, orientation programs, workshops, training programs and similar programs
28. Student projects
- Percentage of students who have done in-house projects including inter-departmental projects
(A) 95% students had done in-house projects
 - Percentage of students doing projects in collaboration with other universities / industry / institute
(A) 05% Students done at collaboration institutes
29. Awards / recognitions received at the national and international level by
- Faculty: Dr. Himanshu Bariya; Young Scientist Award by DST, Govt of India (2013).
 - Doctoral / post-doctoral fellows: Ms. Prerna Patel; Women Scientist WOS-A
 - Students: INSPIRE Award (DST) – Mr. Dharmendra Prajapati (2013)
30. Seminars/ Conferences/Workshops organized and the source of funding (national / international) with details of outstanding participants, if any.

Sr. No.	Name of Conference	National / International	Funding Agency	Number of participants
1	International conference on Biotechnology: for Agriculture, Environment and Society. (29 th March - 1 st April 2012)	International	GSBTM, Gandhinagar	153
2	International Conference on Biochemical and genetic dissection of control of plant mineral nutrition (23 rd to 26 th October, 2013)	International	Bio-NUT and GSBTM, Gandhinagar	Limited to 20.

31. Code of ethics for research followed by the departments
Yes, code of ethics is followed in the department.

32. Student profile programme-wise:

Name of the Programme (refer to question no. 4)	Applications received	Selected		Pass percentage Male Female
		Male	Female	
PG in Biotechnology	25	08	12	100%
M.Phil. In Biotechnology	42	07	23	100%
Ph.D. in Biotechnology	72	13	10	Continue..

33. Diversity of students

Name of the Programme	% of students from the same university	% of students from other universities within the State	% of students from universities outside the State	% of students from other countries
PG	90%	--	10%	---
M.Phil.	6%	94%	---	---
Ph.D.	25%	75%	---	---

34. How many students have cleared Civil Services and Defence Services examinations, NET, SET, GATE and other competitive examinations? Give details category-wise.

Ms. Janki Parmar; GATE (2013)

35. Student progression

Student progression	Percentage against enrolled
UG to PG	
PG to M.Phil.	40 %
PG to Ph.D.	20%
Ph.D. to Post-Doctoral	Not Yet
Employed • Campus selection • Other than campus recruitment	100% (Both)
Entrepreneurs	N/A

36. Diversity of staff

Percentage of faculty who are graduates	
of the same university	-
from other universities within the State	03
from universities from other States	-
from universities outside the country	-

37. Number of faculty who were awarded M.Phil., Ph.D., D.Sc. and D.Litt. during the assessment period

All faculties were having Ph.D. degree prior to appointment as

assistant professor

38. Present details of departmental infrastructural facilities with regard to
- Library: No departmental library
 - Internet facilities for staff and students: available for staff only
 - Total number of class rooms: 02
 - Class rooms with ICT facility: 00
 - Students' laboratories: 02
 - Research laboratories: 00
39. List of doctoral, post-doctoral students and Research Associates
- From the host institution/university : 08 Doctoral Students
 - From other institutions/universities : 15 Doctoral students
40. Number of post-graduate students getting financial assistance from the university.
Top 5 students are getting financial assistance from University as per rules.
41. Was any need assessment exercise undertaken before the development of new programme(s)? If so, highlight the methodology.
As per KCG guidelines new curriculum developed
42. Does the department obtain feedback from
- Faculty on curriculum as well as teaching-learning-evaluation? If yes, how does the department utilize the feedback?
 - Yes University has prepared online tool.
 - Students on staff, curriculum and teaching-learning-evaluation and how does the department utilize the feedback?
 - Yes University has prepared online tool.
 - Alumni and employers on the programmes offered and how does the department utilize the feedback?
 - Yes University has prepared online tool.
 - Department regularly organize staff meeting and staff-students meetings.
43. List the distinguished alumni of the department (maximum 10)
N.A.
44. Give details of student enrichment programmes (special lectures / workshops / seminar) involving external experts.
 - Eminent academic persons / Scientists visited our department and

there are special lectures of these persons. List is as below

Sr. No.	Name of Scientists/ Eminent professor	Place	Date
1	Dr. H.S. Mishra	Molecular Biology laboratory, BARC, Mumbai	28/07/2011
2	Dr. Luit Je De Kok	University of Groningen, The Netherlands	28/07/2011
3	Dr. Malcolm Howkshford	Rothamsted Research Centre, UK	28/07/2011

- Department organized three day bioinformatics training for students by inviting expert faculty from Luknow (Mr. Ankur Mohan and Ms. Pallavi Gangwar) in 2012.
- Seminars are organized by Department

45. List the teaching methods adopted by the faculty for different programmes.

- Power-point presentations, animations, Audio-visual facilities often used by faculties in lectures.
- Quiz is organized for skill development.
- Field study for demonstration of experiment

46. How does the department ensure that programme objectives are constantly met and learning outcomes are monitored?

Feedback forms are filled by students and past students profile are regularly updated on terms of getting employments of students.

47. Highlight the participation of students and faculty in extension activities.

Blood Testing Day was celebrated on 26th January 2013. All staff members and students were involved in this day.

48. Give details of "beyond syllabus scholarly activities" of the department.

- There are 07 ongoing Research projects in department.
- Students are motivated to participate in conference / seminars/ workshops and presenting poster or oral.
- Educational tours are organized regularly.

49. State whether the programme/ department is accredited/ graded by other agencies? If yes, give details.

No

50. Briefly highlight the contributions of the department in generating new knowledge, basic or applied.

- Biotechnology is applied subjects. Students are made aware of latest happening across the globe.
- Quality human resources are developing through research.

51. Detail five major Strengths, Weaknesses, Opportunities and Challenges (SWOC) of the department.

A. Strength:

- Quality teaching with UGC regulations
- Research opportunities with number of research projects
- Research fellowships available for students through research projects
- Advance research facility available through departmental collaboration with national and international institutions
- Good career options are made available by quality teaching and research.

B. Weakness:

- Staff shortage
- Instrument facility hampered
- Dearth of student understanding due to socio-economic condition of this region
- Negligence towards departmental requirement by University and state government due to self-finance status.
- Departmental building is not available

C. Opportunity and Challenges:

- Students & faculty exchange through national and international collaboration.
Ex. 1. Dr. Ashish Patel visited University of Groningen, Netherlands
Ex. 2. Mr. Dharmendra Prajapati is pursuing Ph.D. at University of Groningen, Netherlands

- Research group established by MOU with GSBTM, Gandhinagar is proving leading research group across country.
- Department students are getting sophisticated instrumental facility through MOU which helps in shaping their career.
- Possibility of industry- Academia interactions in future
- A region has potential in disposing research service in Agricultural and medical related field.

52. Future plans of the department.

- Our most important future plannings are as below
 1. To make affordable teaching to students by getting government grant.
 2. To excel in teaching and research.
 3. To attract more and more Biotech companies for Campus interview.
 4. Scholarship for M.Phil and Ph.D. students.

* * * * *

Department of Computer Science

1. Name of the Department: Department of Computer Science, Patan
2. Year of establishment : 1996
3. Is the Department part of a School/Faculty of the university? : Yes
4. Names of programmes offered (UG, PG, M.Phil., Ph.D., Integrated Masters; Integrated Ph.D., D.Sc., D.Litt., etc.)
 1. Ph. D.
 2. M. Sc. (CA & IT)
 3. MCA (3 Years) & MCA (2 Years) Lateral Entry
 4. Integrated MCA (5 Years)
 5. PGDCA
5. Interdisciplinary programmes and departments involved : Nil
6. Courses in collaboration with other universities, industries, foreign institutions, etc. Nil
7. Details of programmes discontinued, if any, with reasons : Nil
8. Examination System: Annual/Semester/Trimester/Choice Based Credit System
Semester / Choice Based Credit System
9. Participation of the department in the courses offered by other departments
Nil
10. Number of teaching posts sanctioned, filled and actual (Professors/Associate Professors/Asst. Professors/others)

	Sanctioned	Filled	Actual including CAS & MPS
Professor	01	01	01
Associate Professor	-	-	-
Assistant Professor	09	09	09
Others	09	09	09

11. Faculty profile with name, qualification, designation, area of specialization, experience and research under guidance

Name	Qualification	Designation	Specialization	No. of Years of Experience	No. of Ph.D./ M.Phil. students guided for the last 4 years
Dr. A. R. Patel	Ph.D. (Computer Science)	Professor & Head	E-Governance, Programming-ERP-SAP (ABAP)	25	07
B. M. Patel	M. Tech (CS) Ph. D. Pursuing	Assistant Professor	D.B.M.S. (SQL, PL/SQL) ORACLE, Adv. Database, Data Mining & Data ware Housing.	10	Nil
V. H. Bhemwala	M. Sc. (CA & IT), Ph. D. Pursuing	Assistant Professor	Operating System, Advanced Operating System, Embedded System	8	Nil
R. D. Prajapati	M. Tech (CS)	Assistant Professor	DBMS (Oracle), Visual Basic, Computer Architecture & Organization, Web Designing (HTML, CSS, Java Script, ASP), .Net Technology, Ajax, Silver Light, XML Technology	8	Nil
K. I. Chokhawala	MCA, Ph. D. Pursuing	Assistant Professor	Advanced Web Technology (.NET), Data Structure, D.B.M.S.(SQL, PL/SQL), Algorithms, Visual Programming using VC++, Embedded System	5	Nil
J. N. Modi	M. Tech (CS) Ph. D. Pursuing	Assistant Professor	DBMS, OS, Parallel Processing, System Programming, Data warehouse, Web Development with PHP tools, Networking.	5	Nil
J. B. Patel	MCA, Ph. D. Pursuing	Assistant Professor	Computer Graphics, Internet & Web Designing (HTML, CSS, Dreamweaver,	5	Nil

			Flash),Java, JSP, Servlet, Networking		
R.J.Patel	M.C.A. Ph. D. Pursuing	Assistant Professor	Discrete Mathematics, Numerical & Statistical Analysis, Operation Research.	3	Nil
A.C.Rajput	M.Sc.(C.A. & I.T.). Ph. D. Pursuing	Assistant Professor	Artificial Intelligence, Software Engineering, JAVA, SAD, Visual Basic 6.0, C++, C, Basic Computer Applications	3	Nil
H.N.Prajapati	M.Sc.(C.A. & I.T) Ph. D. Pursuing	Assistant Professor	C, C++,JAVA, Oracle 10g	3	Nil

12. List of senior Visiting Fellows, adjunct faculty, emeritus professors

Sr. No.	Name	Affiliation
1	Dr. Vipin Gupta	California State University, USA
2	Prof. Bijoy Bardoloi	Southern Eillinois University, USA
3	Dr. Joel Rodney	Pennsvlvania state University, USA
4	Dr. Shamir Shah	Pennsvlvania state University, USA
5	Prof. Murray Woods	Canberra University, Australia
6	Prof. Stephan Parkar	Canberra University, Australia
7.	Dr. Arvind C. Shah	GSW State University
8	Prof. Brain Adler	GSW State University

13. Percentage of classes taken by temporary faculty – programme-wise information

1. M. Sc. (CA & IT) 15%
2. MCA (3 Years) 10%
3. MCA (5 Years) 15%

14. Programme-wise Student Teacher Ratio

1. M. Sc. (CA & IT) 25 : 1
2. MCA (3 Years) 25 : 1
3. MCA (5 Years) 25 : 1

15. Number of academic support staff (technical) and administrative staff: sanctioned, filled and actual

	Sanctioned	Filled	Actual
Tech. assistant	08	08	08
Clerck	02	02	02
Programmer	01	01	01

16. Research thrust areas as recognized by major funding agencies Nil
17. Number of faculty with ongoing projects from a) national b) international funding agencies and c) Total grants received. Give the names of the funding agencies, project title and grants received project-wise. Nil
18. Inter-institutional collaborative projects and associated grants received
a) National collaboration Nil
b) International collaboration Nil
19. Departmental projects funded by DST-FIST; UGC-SAP/CAS, DPE; DBT, ICSSR, AICTE, etc.; total grants received.
Nil
20. Research facility / centre with
• state recognition -Nil-
• national recognition -Nil-
• international recognition -Nil
21. Special research laboratories sponsored by / created by industry or corporate bodies -Nil-
22. Publications:
➤ Papers published in peer reviewed journals (national / international)

Sr. No.	Faculty Name	Paper Description	Impact factor
1	Dr:A.R .Patel	1. Patel A R, Kothari A D, "On Demand Temporary Parallel Route Recovery for frequent link Failure in Adhoc Networks.", International Journal of Computer Application (ISBN 0975-8887) digital Library Volume 11 Article-1, December 2010, available on line at : www.ijcaonline.org/archives/volume11/number11/1630-2191	
		2. Patel A R, Dharva Jyotindra, "A Data Mining with Hybrid Approach Based Transaction Risk Score Generation Model (TRSGM) for Fraud Detection of Online Financial Transaction" Digital Library of International Journal of Computer Application, Published online from 28th February 2011. URL http://www.ijcaonline.org/archives/volume16/number1/1977-2651 ISBN: 978-93-80747-55-0	

	3. Ashok R Patel, Amit D. Kothari and Divyakant T. Meva, "Comparative study and Analysis of AODTPRR with DSR, DSDV and AODV for Mobile Ad Hoc Network", Published in the International Journal of Information Technology & Knowledge Management (ISSN 0973-4414) Vol-IV, Issue-II of June 2011, http://www.csjournals.com/IJITKM/ijitkmVol4-2.html	
	4. Ashok R. Patel, Ms. Meghna B. Patel, Mr. Ronak B. Patel, "Components of Fingerprint Biometric System", International Journal of Engineering Research & Technology (IJERT), http://www.ijert.org/browse/may-2012-edition?start=140 , ISSN: 2278-0181, Vol. 1 Issue 3, May – 2012.	IF 1.76
	5. A R Patel, Ajay M. Patel, Hiral R. Patel, International Journal of Computer Applications, IJCA July 2012 Edition, " Exploratory Data Model for Effective WLAN Anomaly Detection based on Feature Construction and Reduction", ISBN: 973-93-80869-55-7 Digital Library URI : http://www.ijcaonline.org/archives/volume50/number6/7776-0861	
	6. A R Patel, Ketul B Patel, International Journal of Computers & Technology, "Process of Web Usage Mining to find Interesting Patterns from Web Usage Data". www.ijctonline.com , ISSN: 2277-3061 Volume 3, No. 1, AUG, 2012.	
	7. Patel, A.R, Banga Abdulbasit, "An Analytic and Parametric Study and Comparison of Software Cost Estimation Models", International Journal of Advanced Research in Computer Science and Software Engineering (IJARCSSE), ISSN 2277-128X, http://www.ijarcsse.com/9_September2012.php Volume 2 Issue 9, September 2012.	
	8. Patel A R, Dharva Jyotindra, "A Transaction Pattern Generation Tool (Tpgt) For Prediction Of Online Financial Transaction", Journal of Computer Technology & Applications., STM Journals, ISSN 2229 – 6964, Vol 3 No 3 (2012), http://stmjournals.com/index.php?journal=JoCTA&pa	

	ge=article&op=view&path%5B%5D=2540	
	9. A R Patel, Ajay M. Patel, Hiral R. Patel, International Journal of Computer Engineering & Technology, IJCET Vol 4, Issue 2, March – April 2013 pp 241-251, “ A Comparative Analysis of Data Mining Tools for Performance mapping of WLAN Data.”, Digital Library URI : http://www.iaeme.com/Journalcureentissue.asp?VType=4&IType=2&JType=IJCET&PageNumber=3 , ISBN: 0976- 6375(Online).	
	10. A R Patel, Meghna B Patel, International Journal of Recent Technology and Engineering (IJRITE) ISSN: 2277-3878, Volume 2, Issue 2, May 2013 pp 200-203, “Performance Improvement by Classification Approach for Fingerprint Identification System”, Digital Library http://www.ijrte.org/v2i2.php	
	11.A R Patel, Ajay M. Patel, Hiral R. Patel, International Journal of Computer Technology & Applications (IJCTA), ISSN 2229-6093, Volume 5, Issue 1, January – February 2014 pp 123-129, “Analytical Revision of Anomaly Intrusion Detection Performance Bases on Diversity of Domain, ICV 5.17, Digital Library http://www.ijcta.com/vol5issue1.php	IF 2.015
	12. A R Patel, Meghna B. Patel, N. J. Patel, International Journal of Computer Technology and Applications (IJCTA), ISSN: 2229-6093, Volume-5, Issue-1, January-February 2014, pp 189-197, Impact Factor – 2.015 IC Value-5.17, “Comparative Study on Different Fingerprint Classification Approaches” at Library http://www.ijcta.com/vol5issue1-page2.php	IF 2.015
	13. A R Patel, Bhavesh Patel, Bharat Prajapati, Jyotindra Dharwa, International Journal of Innovative Research in Computer Science & Technology (IJRCST) ISSN: 2347- 5552, Volume 2, Issue 2, March 2014 pp 19-25, “Study and Evaluation of student Performance Parameters using statistical features of excel”, Digital Library http://www.ijrcst.org/User/Arch.aspx?rep=15	IF 2.081
	14. A R Patel, Pareshkumar J. Patel, Narendra J. Patel, International Journal of Application or Innovation in Engineering & Management, ISSN 2319 - 4847,	IF 3.115

		Volume 3, Issue 3, March 2014 pp 53-56 “Factors affecting Currency Exchange Rate, Economical Formulas and Prediction Models” Digital Library http://www.ijaiem.org/V3I3.html	
		15. A R Patel, Ketul B Patel, Natvar S. Patel, International Journal of Scientific Research Engineering & Technology (IJSRET), ISSN 2278 – 0882, Volume 3 Issue 1, April 2014, pp 8-12, “Web Advertising Personalization using Web Content Mining and Web Usage Mining Combination” Digital Library http://www.ijret.org/volume3_issue1.php	
		16. A R Patel, Badal K Kothari, International Journal of Computer Engineering and Applications (IJCEA),ISSN: 2321-3469, Volume VII Issue III, September 2014,”Cube Indexing Implementation Using Integration of Sidera and Berkeley DB”. Digital Library http://www.ijcea.com/cube-indexing-implementation-using-integration-sidera-berkeley-db/	IF 2.849
		17. A R Patel, Jayesh N Modi, Jignesh B Patel, International Journal of Advanced Research in Computer Science and Software Engineering (IJARCSSE), ISSN: 2277 128X, Volume 4 Issue 9, September 2014, “Comparative Study of Multimedia over Mobile Generation”, Digital Library http://www.ijarcsse.com/docs/papers/Volume_4/9_September2014/V4I9-0425.pdf	IF 2.08
		18. A R Patel, Jignesh Patel, Jayesh N Modi, International Journal of Emerging Trends & Technology in Computer Science (IJETTCS), ISSN 2278-6856, Volume 3, Issue 5, September-October 2014, “RFID Modules & Guideline for selecting appropriate RFID Module for Industries”, Digital Library http://www.ijettcs.org/Volume3Issue5/IJETTCS-2014-09-29-44.pdf	IF 3.258
2	Jayesh Modi	1. Jayesh N Modi, A R Patel, Jignesh B Patel, International Journal of Advanced Research in Computer Science and Software Engineering (IJARCSSE), ISSN: 2277 128X, Volume 4 Issue 9, September 2014, “Comparative Study of Multimedia over Mobile Generation”, Digital Library	IF 2.08

		http://www.ijarcsse.com/docs/papers/Volume_4/9_September2014/V4I9-0425.pdf	
		2. A R Patel, Jignesh Patel, Jayesh N Modi, International Journal of Emerging Trends & Technology in Computer Science (IJETTCS), ISSN 2278-6856, Volume 3, Issue 5, September-October 2014, “RFID Modules & Guideline for selecting appropriate RFID Module for Industries”, Digital Library http://www.ijettcs.org/Volume3Issue5/IJETTCS-2014-09-29-44.pdf	IF 3.258
3	Jignesh Patel	1. Jignesh Patel , Badal Kothari “NEAR FIELD COMMUNICATION - THE FUTURE TECHNOLOGY FOR AN INTERACTIVE WORLD”- International journal of Engineering Research and Science & Technology, ISSN 2319-5991, page no. 55-59, Vol. 2, No. 2, May 2013. (Available online at: http://www.ijerst.com/previousissue.php?year=2013&issue=2).	
		2. Jayesh N Modi, Jignesh B Patel, A R Patel, International Journal of Advanced Research in Computer Science and Software Engineering (IJARCSSE), ISSN: 2277 128X, Volume 4 Issue 9, September 2014, “Comparative Study of Multimedia over Mobile Generation”, Digital Library http://www.ijarcsse.com/docs/papers/Volume_4/9_September2014/V4I9-0425.pdf	IF 2.08
		3. Jignesh Patel, A R Patel, Jayesh N Modi, International Journal of Emerging Trends & Technology in Computer Science (IJETTCS), ISSN 2278-6856, Volume 3, Issue 5, September-October 2014, “RFID Modules & Guideline for selecting appropriate RFID Module for Industries”, Digital Library http://www.ijettcs.org/Volume3Issue5/IJETTCS-2014-09-29-44.pdf	IF 3.258
4	Alpa Rajput	1. Alpa rajpu, proceeding of 19 th Annual Cum 4 th International Conference of Gwalior Academy of Mathematical sciences, SVNIT, Surat, Oct 2014, “Comprehensive Model of Intelligent Decision	

		Support System for Higher Education Admission Management” ISBN:978-81-928100-8-9	
--	--	--	--

- * Monographs Nil
 - Chapters in Books Nil
 - Edited Books: 02
 1. Book India Publication, Ahmedabad
 2. Macmillan India Private Limited, New Delhi
 - Books with ISBN with details of publishers : 02
 - Data Structure With C, ISBN : 10-0230-33240-4
 - Database Management System – Concept, Design, Architecture & SQL, ISBN : 13-978-0230-33240-9
 - Number listed in International Database (For *e.g.* Web of Science, Scopus, Humanities International Complete, Dare Database - International Social Sciences Directory, EBSCO host, etc.) Nil
 - Citation Index – range / average Nil
 - SNIP Nil
 - SJR Nil
 - Impact Factor – range / average Nil
 - h-index Nil
23. Details of patents and income generated Nil
24. Areas of consultancy and income generated Nil
25. Faculty selected nationally / internationally to visit other laboratories / institutions/ industries in India and abroad
1. Dr. A. R. Patel
26. Faculty serving in
- a) National committees b) International committees c) Editorial Boards d) any other (please specify) Nil
27. Faculty recharging strategies (UGC, ASC, Refresher / orientation programs, workshops, training programs and similar programs).
1. Orientation
 2. Short Term Training Program
 3. Workshop
 4. Conference

28. Student projects
- percentage of students who have done in-house projects including inter-departmental projects 05%
 - percentage of students doing projects in collaboration with other universities / industry / institute 25%
29. Awards / recognitions received at the national and international level by
- Faculty Nil
 - Doctoral / post doctoral fellows Nil
 - Students
 1. Minaxi Lalit Scholar Award
 2. Chankya award, 2013
 3. Abhimanyu Award, 2012
 4. IBM Academic Initiative, 2014
30. Seminars/ Conferences/Workshops organized and the source of funding (national / international) with details of outstanding participants, if any.

Sr. No.	Title	No. of Participant
1	CSI Regional Student Convention	200
2	One day seminar of Super Computing	100
3	Workshop on devices : transforming education by Microsoft	30
4	Faculty development program by IUCEE	50

31. Code of ethics for research followed by the departments
The department faculties follow the code of ethics in their research.

32. Student profile programme-wise:

Name of the Programme (refer to question no. 4)	Applications received	Selected		Pass percentage	
		Male	Female	Male	Female
M. Sc. (CA & IT)	1500	95	65	74.1%	50.7%
MCA (3 Years)	Centralized	18	12	90.00%	95.00%
Ph. D.	--	--	--	--	--
PGDCA	100	38	22	75%	80%

33. Diversity of students

Name of the Programme (refer to question no. 4)	% of students from the same university	% of students from other universities within the State	% of students from universities outside the State	% of students from other countries
M. Sc. (CA & IT)	80%	10%	10%	--
MCA (3 Years)	75%	15%	10%	--
MCA (5 Years)	77%	12%	11%	--
PGDCA	76%	14%	10%	--

34. How many students have cleared Civil Services and Defense Services examinations, NET, SET, GATE and other competitive examinations? Give details category-wise.

1. Civil Services - 01
2. NET, SET, GATE - 01

35. Student progression

Student progression	Percentage against enrolled
UG to PG	73%
PG to M.Phil.	--
PG to Ph.D.	2%
Ph.D. to Post-Doctoral	--
Employed	
<input type="checkbox"/> Campus selection	45%
<input type="checkbox"/> Other than campus recruitment	50%
Entrepreneurs	5%

36. Diversity of staff

Percentage of faculty who are graduates

Of the same university	80%
from other universities within the State	20%
from universities from other States	Nil
from universities outside the country	Nil

37. Number of faculty who were awarded M.Phil., Ph.D., D.Sc. and D.Litt. during the assessment period

Nil

38. Present details of departmental infrastructural facilities with regard to
- | | |
|--|--------------------------------|
| a) Library | 17462 |
| b) Internet facilities for staff and students
office having WiFi internet facility. | All Labs, Teacher Chambers and |
| c) Total number of class rooms | 10 |
| d) Class rooms with ICT facility | 10 |
| e) Students' laboratories | 08 |
| f) Research laboratories | 01 |
39. List of doctoral, post-doctoral students and Research Associates
- a) from the host institution/university
1. Tejal A. Patel
 2. Jigar V. Patel
 3. Nimesh I. Modi
- b) from other institutions/universities
1. Ritu Bhargava
 2. Sivsingh Sarangdevot
 3. Amit Kothari
 4. V. V. Nath
 5. A. S. Banga
40. Number of post graduate students getting financial assistance from the university.
05
41. Was any need assessment exercise undertaken before the development of new programme(s)? If so, highlight the methodology. Yes
42. Does the department obtain feedback from
- i. faculty on curriculum as well as teaching-learning-evaluation? If yes, how does the department utilize the feedback? Yes, improvisation of subject curriculum, to offer subject as per industry requirements to improve faculty teaching and learning technique.
 - ii. students on staff, curriculum and teaching-learning-evaluation and how does the department utilize the feedback? Yes, teaching improvement, preparation of learning material, improvisation of infrastructure facility
 - iii. alumni and employers on the programmes offered and how does the department utilize the feedback? Yes, improvisation of syllabus as per

industry requirement time by time and to introduced to new tools and technologies to provide user friendly environment in institute like company.

43. List the distinguished alumni of the department (maximum 10)

Sr. No.	Name
1	Vishal Bhemwala
2	Jigqar Joshi
3	Darshana Dalwadi
4	Kirit Chokhawal
5	Jignesh Patel
6	Tushar Parikh
7	Jignesh Rami
8	Nimesh Modi
9	Haresh Prajapati
10	Ketan Patel

44. Give details of student enrichment programmes (special lectures / workshops / seminar) involving external experts.

Sr. No	Name	Activity
1	Dr. Bhupendra Chaudhary, NIC Mehsana	Special Lecture
2	Prof. Budhhdev, LD Engineering, Ahmedabad	Special Lecture
3	Prof. Ashok T. Amin, DA-IICT, Gandhinagar	Special Lecture
4	Prof. Bhusan Trivedi, GLS, Ahmedabad	Special Lecture
5	Prof. M. T. Savalia, LD Engineering, Ahmedabad	Special Lecture
6	Prof. S. M. Shah, LD Engineering, Ahmedabad	Special Lecture
7	Aditya Maheswari, Recruitment Team, Google, India	Workshop
8	Aditya Maheswari, Recruitment Team, Google, India	Special Lecture

45. List the teaching methods adopted by the faculty for different programmes.
Interactive & Questionnaires based

46. How does the department ensure that programme objectives are constantly met and learning outcomes are monitored?

By conducting various test at time, which helps students to refresh their knowledge and after that giving justification for marks.

47. Highlight the participation of students and faculty in extension activities.

Students are encouraged to participate by paying their registration fees in nation and international seminars, workshops and conferences.

48. Give details of “beyond syllabus scholarly activities” of the department.
Students are regularly participating in sports activity like cricket, basketball, volleyball, yoga and health.
49. State whether the programme/ department is accredited/ graded by other agencies? If yes, give details.
Yes, AICTE
50. Briefly highlight the contributions of the department in generating new knowledge, basic or applied.
Nil
51. Detail five major Strengths, Weaknesses, Opportunities and Challenges (SWOC) of the department.
Strengths
- Qualified Staff
 - Infrastructure
 - Team work
- Weakness
- For vast number of Students still needs extended Infrastructure.
 - Industrial Exposure.
- Opportunity
- Strong Alumni association.
 - Well Equipped Library.
 - Students permitted to access WIFI network all around.
- Challenges: To give opportunity to and uplift the students of rural and tribal areas of north Gujarat and put them into main stream of it era.
52. Future plans of the department.
Extension of Infrastructure for new courses.

* * * * *

Department of Education

1. Name of the Department:- Education Department
2. Year of establishment:- June 2005
3. Is the Department part of a School/Faculty of the university?:-
Post Graduate Department of University
4. Names of programmes offered (UG, PG, M.Phil., Ph.D., Integrated Masters; Integrated Ph.D., D.Sc., D.Litt., etc.) :
PG Programme: M.Ed., M.A.(Education), M.Phil., Ph.D.,
5. Interdisciplinary programmes and departments involved: No
6. Courses in collaboration with other universities, industries, foreign institutions, etc.
No
7. Details of programmes discontinued, if any, with reasons:- No.
8. Examination System: Annual/Semester/Trimester/Choice Based Credit System :
Semester, Choice Based Credit System
9. Participation of the department in the courses offered by other departments.
No such courses offered.
10. Number of teaching posts sanctioned, filled and actual (Professors/Associate Professors/Asst. Professors/others)

	Sanctioned	Filled Per Unit	Actual (including CAS & MPS)
Professor	1	-	-
Associate Professors	1	1	1
Asst. Professors	3	3	3
Others	-	-	-

11. Faculty profile with name, qualification, designation, area of specialization, experience and research under guidance

Name	Qualification	Designation	Specialization	No. of Years of Experience	No. of Ph.D./M.Phil. students guided for the last 4 years
Dr. S. G. Patel	M.A.(Sanskrit), M.A.(Psychology), M.Ed., Ph.D.	Associate Professor	Educational Psychology, Research, Measurement & Evaluation, Psycho. Testing	19	M.Phil. 25 Ph.D. 6 students are registered
Dr. R. R. Patel	M.Sc., M.Ed., Ph.D.	Assistant Professor	Educational Psychology, Research, Measurement & Evaluation, Psycho. Testin	10	M.Phil. 20 Ph.D. 6 students are registered
Dr. J. K. Joshi	M.A., M.Ed., M.Phil., Ph.D.	Assistant Professor	Educational Technology, Research, Vocational Guidance, Educational Psychology	07	M.Phil. 14 Ph.D. 5 students are registered
Dr. S. H. Tandel	M.Sc., M.Ed., Ph.D.	Assistant Professor	Educational Philosophy, Educational Sociology, Research, Stat. in Edu.	09	M.Phil. 10 Ph.D. 6 students are registered

1. List of senior Visiting Fellows, adjunct faculty, emeritus professors

1. Dr. J. H. Pancholi
2. Dr. S.P. Sharma
3. Dr. C.P. Swami
4. Dr. V.V. Chaudhari
5. Dr. S.C. Padvi
6. Dr. I.M. Badiyani

13. Percentage of classes taken by temporary faculty – programme-wise information

14. Programme-wise Student Teacher Ratio: M.Ed. 7:1
 M.Phil. (Edu.) 5:1
 M.A. (Edu.) 5:1

15. Number of academic support staff (technical) and administrative staff: sanctioned, filled and actual

	Sanctioned	Filled	Actual
Clerk	1	1	1
Peon	1	1	1
Sweeper	1	1	1
Others	-	-	-

16. Research thrust areas as recognized by major funding agencies:

Primary Education

17. Number of faculty with ongoing projects from a) national b) international funding agencies and c) Total grants received. Give the names of the funding agencies, project title and grants received project-wise.

Mr.S.H.Tandel:

Sr. No.	Title	Agency	Sanction Date	Period	Amount	Duration (Month & Year)
1.	A Comparative study of primary schools having	SSA Gandhinagar	Ssa/r& d /2013/8324-8325 Date:1/03/2013	One year	Rs. 6,70,540/-	12 Months

	higher & lower grade assigned during Gunotsav					
2.	A Study of Administrative & Cultural Adaptation required for Access, Retention and Learning of Tribal Children	SSA Gandhinagar	SSA/R & E/2014/29416	One year	Rs. 7,57,777/-	12 Months

18. Inter-institutional collaborative projects and associated grants received

a) National collaboration b) International collaboration : Nil

19. Departmental projects funded by DST-FIST; UGC-SAP/CAS, DPE; DBT, ICSSR, AICTE, etc.; total grants received. : Nil

20. Research facility / centre with

- state recognition : SSA, Gandhinagar
- national recognition : Nil
- international recognition : Nil

21. Special research laboratories sponsored by / created by industry or corporate bodies :- N.A.

22. Publications:

- * Number of papers published in peer reviewed journals (national / international) :-

Dr.S.G.Patel: 06 Research and Publication Work in Education

No.	Year	Journal	Co author	Subject
1	June 2011	International Journal of Education for	---	A Study of English Speaking Anxiety of the Secondary School Students of

		Human Services ISSN : 0976 – 1128		Banaskantha District (Gujarat)
2	2012	H.N.G.Uni. Anarta Special Issue	---	A Study of Moral Reasoning Ability of Secondary School's Students
3	May 2012	Anarta – 13 Vol.-2 Hem. N. G. Uni., Patan ISSN: 2229 - 4376	---	Environmental Literacy & the Role of Universities
4	February - 2013	IJRE Vol.: 2, Issue :2 ISSN -: 2320 – 091X	---	TQM in Higher Education Institution (HEIs)
5	March 2013	Prakalp ISSN : 2229-3395	Dr.J.K. Joshi	Sthita-Pragna Personality
6	Accepted	Special Issue H. N. G. Uni. , Patan	----	Cross Disciplinary International Seminar On Assessing Excellence in Social Sciences and Humanities: Concepts and Methods

Dr.R. R. Patel 13 Research and Publication Work in Education

No	Year	Journal	Co-author	subject
1	Vol.3 march13	Educational journal of education for human services	Dr. S. H. Tandel	College Teachers' awareness regarding choice based credit system (109-114)
2	Vol.1 March13	Indian e-journal on teacher education	none	Try out of developed instructional strategy to teach creative and critical thinking (62-70)
3	Vol. 2 Dec-12	2248-9703	Dr. Hiral Barot	ICT: a pillar in Education & training programme (205-207)

4	Vol.4 March-13	Haim-prapa	Dr. Dilip C. Patel	Mathematics in literature and music: reflections of Hemchandracharya (35-37)
5	Vol.5 March-10	Aditya kiran	none	Vivekanand (10-11)
6	July 12	Aditya kiran	Chidanand Trivedi	North Gujarat University (18-19)
7	Vol.1 May 13	Indian e-journal on teacher education	none	Effectiveness of de Bono thinking tools on enhancing students critical and creative thinking (21-30)
8	Vol.3 June-13	Educational journal of education for human services	none	Secondary school teachers awareness regarding educational programmes on television (68-70)
9	Vol.1 July-13	Indian e-journal on teacher education	none	Construction and effectiveness of a programme for improvement of English pronunciation of the students of Std VIII of secondary schools of Himmatnagar taluka (25-32)
10	Vol.3 June 13	2248-9703	none	Development and implementation of a vocational guidance programme for the secondary schools. (237-245)
11	Vol. 2 April-june-13	Shiskan darshan	none	Theory of multiple intelligence(42-46)
12	Nov-dec-2011	Majanu Ganit	none	Tarkshakti no abhav ane ganit shikshan no probhav (39-41)
13	Sept-13	Indian e-journal on teacher education	Dr. Makwana	A study of learning through computer assisted learning material in relation to selected production variables and contiguity

No	Year	Journal	Co author	Subject
1	July,2011	Research Waves ISSN: 2229-6387	Dr.N.G.Ghosh	A Study of Job Satisfaction among Adyapak Sahayak
2	October, 2011	Research Waves ISSN: 2229-6387	Dr.N.G.Ghosh	Study of the Teacher Burn-out in Relation to Professional Aspect
3	December, 2011	International Journal of Education for Human Services ISSN: 0976-1128	---	Achievement Motivation of the Higher Secondary School Students with Reference to Certain Variables
4	May 2012	Anarta-13 Vol. – 2 Hem.N.G.uni.,Patan ISSN: 2229-4376	---	Teaching as “Disciplined Improvisational Performance”
5	January 2013	Paripex -Indian Journal of Research Vol. -2, Issue – 1 ISSN: 2250-1991	Dr.N.G.Ghosh	A Critical Analysis of the Merit Scheme of Adyapak Sahayak

				(Substitute Teacher Educator)
6	March 2013	Prakalp Year-4, Vol. – 03 ISSN: 2249-3395	Dr. S. G. Patel	Sthita-Pragna Personality
7	July-September, 2013	Edutrends : A Peer Reviewed Journal of Teacher Education ISSN: 2321-2020	---	Experiences of the 9 th Standard Students while Speaking in English
8	Accepted	Special Issue Hem. N.G. university	---	Role of Women in Environment Sustainability

Dr. S. H. Tandel: 09 Research and Publication Work in Education:

Sr. No.	Year	Journals & ISSN No.	Name of co-authors	Title
1.	2012	Research Expo International Mulidisciplinary Reseach Journal 2250-1630	Dr. Pinal Gordiya	Effectiveness of Constructivist 5 'E' Model
2.	2012	Recent Thought 2278 – 4608	Dr. Chaman Sharma	Menace of Ragging: A View of Stake Holders
3.	2012	PARIPEX - INDIAN JOURNAL OF RESEARCH 2250-1991	---	Complex Relation Between Metacognition and Cognition
4.	2012	Quest -Journal of ASC-Nainital 0974-5041	Dr. Pinal Gordiya	Meta-Analysis of Effectiveness of Computer Aided Instruction Method
5.	2012	Aanart- Journal of	---	Tools for Assessing

		Hemchandracharya North Gujarat University 2229-4376		Metacognitive Skills – A Critical Understanding and a meaningful tool
6.	2013	INTERNATIONAL JOURNAL OF EDUCATION FOR HUMAN SERVICES 0976-1128	Dr. R.R.Patel	College Teachers Awareness regarding CBCS
7.	2013	INTERNATIONAL JOURNAL OF EDUCATION FOR HUMAN SERVICES 0976-1128	—	Meta-Analysis of Effectiveness of Work-Card Method
8.	2013	Global Research Analysis 2277-8160	Dr. Pinal Gordiya	Meta-Analysis of Effectiveness of Programme Learning Method
9.	2013	Educational Quest 0976-7258	—	Development of Metacognitive Skills in Science Student-Teachers through Constructivist Approach

Book Publication:

Sr. No.	Year	Title	Book Title, Editor & Publisher ISBN No.	No of Co-authors
1.	2013	Research Ethics	Research Methodology in Education and Social Science Prof. D. A. Uchat Paras Publication 978-93-5067-053-8	four

* Monographs: Nil

* Chapters in Books:
Dr.S.G.Patel : 01 Dr.S.H.Tandel: 01

* Edited Books: 01

- * Books with ISBN with details of publishers:
Dr.R.R.Patel: 01

No.	Title With Page No.	Publishers & ISSN/ISBN No.
1.	Development and implementation of a vocational guidance programme	978-3-65940384-2
2.	Analysis of computer assisted learning material	978-3-659-40502-0
3	Pronunciation improvement programme in English	978-3-659-40609-6
4	Teaching critical and creative thinking: a guide for primary school teacher	978-3847344247

- * Number listed in International Database (For *e.g.* Web of Science, Scopus, Humanities International Complete, Dare Database - International Social Sciences Directory, EBSCO host, etc.) NIL
- * Citation Index – range / average NIL
- * SNIP NIL
- * SJR NIL
- * Impact Factor – range / average NIL
- * h-index NIL

23. Details of patents and income generated : Not applicable

24. Areas of consultancy and income generated:
Recruitment, Examination, Free Consultancy

25. Faculty selected nationally / internationally to visit other laboratories / institutions / industries in India and abroad: Nil

26. Faculty serving in

a) National committees b) International committees c) Editorial Boards d) any other (please specify):

Dr.S.G.Patel: 1. Udichya

2. Member of Editorial Board in RET Academy for International Journals of Multidisciplinary Research (RAIJMR) : Online International, Reviewed & Indexed Monthly Journal

27. Faculty recharging strategies (UGC, ASC, Refresher / orientation programs, workshops, training programs and similar programs).

Name	Qualification	Orientation Programme	Refresher Course
Dr. S. G. Patel	M.A., M.Ed. Ph.D.	Rajkot ASC	*Rajkot ASC *S.P. Uni., V.V.Nagar
Dr. R. R. Patel	M.Sc., M.Ed. Ph.D.	Rajkot ASC	*Rajkot ASC *S.P. Uni., V.V.Nagar
Dr. J. K. Joshi	M.A., M.Ed., M.Phil. Ph.D.	Rajkot ASC	--
Dr. S. H. Tandel	M.Sc., M.Ed. Ph.D.	ASC-Shimla 09/04/2012 to 05/05/2012	ASC-Nainital 04/12/2013 to 24/12/2013

28. Student projects

- percentage of students who have done in-house projects including inter-departmental projects: 03
- percentage of students doing projects in collaboration with other universities / industry / institute

29. Awards / recognitions received at the national and international level by

- Faculty: Nil
- Doctoral / post doctoral fellows : Nil
- Students : Nil

30. Seminars/ Conferences/Workshops organized and the source of funding (national / international) with details of outstanding participants, if any.

Dr. J.H.Pancholi was Co-coordinator of International Conference organized by H.N.G.U., Patan

31. Code of ethics for research followed by the departments

Yes

32. Student profile programme-wise:

Name of the Programme (refer to question no. 4)	Admission Process	Appli. received	Selected		Pass percentage	
			Male	Female	Male	Female

Name of the Programme (refer to question no. 4)		Admission Process	Appli. receiv ed	Selected		Pass percentage	
				Mal e	Fema le	Male	Femal e
M.Ed.	200 8-09	Centraliz e On Merit	49	31	18	93.55 %	94.44 %
M.Ed.	200 9-10	Centraliz e On Merit	50	21	29	100%	100%
M.Ed.	201 0-11	Centraliz e On Merit	70	36	34	97.22 %	97.06 %
M.Ed.	201 1-12	Centraliz e On Merit	48	22	26	95.45 %	96.15 %
M.Ed.	201 2-13	Centraliz e On Merit	26	10	16	100%	100%
M.Phil.(Educati on) Full Time	200 8-09	Centrali ze On Merit	30	17	13	94.12 %	92.31 %
M.Phil.(Educatio n) Part Time	200 8-09	Centraliz e On Merit	19	16	03	100%	100%
M.Phil.(Educatio n)	200 9-10	Entrance Test	31	17	14	100%	100%
M.Phil.(Educatio n)	201 0-11	Entrance Test	28	15	13	100%	100%
M.Phil.(Educatio n)	201 1-12	Entrance Test	30	24	06	95.83 %	83.33 %
M.Phil.(Educatio n)	201 2-13	Entrance Test	49	29	20	96.55 %	100%
M.Ed.	201 3-14	Centraliz e On Merit	21	2	19	100%	100%
M.Phil.(Educatio n)	201 3-14	Entrance Test On Merit	30	16	14	100%	100%
M.A.(Education)	201 3-14	On Merit	30	20	10	100%	90%

33. Diversity of students

Name of the Programme (refer to question no. 4)		% of students from the same university	% of students from other universities within the State	% of students from universities outside the State	% of students from other countries
M.Ed.	2008-09	46 (93.88%)	3(6.12%)	-----	-----
M.Ed.	2009-10	42(84%)	06(12%)	02(04%)	-----
M.Ed.	2010-11	62(88.57%)	06(8.57%)	02(2.86%)	-----
M.Ed.	2011-12	32(66.66%)	11(22.92%)	05(10.42%)	-----
M.Ed.	2012-13	16(61.54%)	09(34.62%)	01(3.84%)	-----
M.Phil. (Education) Full Time	2008-09	24(80%)	4(13.33%)	2(6.67%)	-----
M.Phil. (Education) Part Time	2008-09	02(10.53%)	06(31.58%)	11(57.89%)	-----
M.Phil. (Education)	2009-10	25(80.65%)	01(3.23%)	05(16.12%)	-----
M.Phil. (Education)	2010-11	20(71.42%)	04(14.29%)	04(14.29%)	-----
M.Phil.(Education)	2011-12	27(90.%)	01(3.33%)	02(6.67%)	-----
M.Phil.(Education)	2012-13	38(77.55%)	05(10.20%)	06(12.25%)	-----
M.Ed.	2013-14	10(47.62%)	07(33.33%)	04(19.05%)	-----
M.Phil.(Education)	2013-14	24(80.00%)	02(6.67%)	04(13.33%)	-----
M.A.(Education)	2013-14	23(76.67%)	06(20.00%)	01(3.33%)	-----

34. How many students have cleared Civil Services and Defence Services examinations, NET, SET, GATE and other competitive examinations? Give details category-wise.

NET	GSET	TET	TAT	H-TAT	Other
10	13	30	30	07	01(DEO)

35. Student progression

Student progression	Percentage against enrolled
UG to PG	---
PG to M.Phil.	50(30.26%)
PG to Ph.D.	18(13.00%)

Student progression	Percentage against enrolled
Ph.D. to Post-Doctoral	---
Employed	
• Campus selection	
• Other than campus recruitment	80%
Entrepreneurs	

36. Diversity of staff

Percentage of faculty who are graduates	
of the same university	02 (50%)
from other universities within the State	02 (50%)
from universities from other States	--
from universities outside the country	--

37. Number of faculty who were awarded M.Phil., Ph.D., D.Sc. and D.Litt. during the assessment period : Ph.D. : 03

38. Present details of departmental infrastructural facilities with regard to

- Library : No departmental library
- Internet facilities for staff and students : Yes
- Total number of class rooms : 02
- Class rooms with ICT facility : No
- Students' laboratories : Computer Laboratory/Psychological Laboratory
- Research laboratories : N.A.

39. List of doctoral, post-doctoral students and Research Associates

- from the host institution/university

Ph.D. Students List				
No.	Name of the Scholar	Title of the Thesis	Year	Guide
1	Prajapati Mangalbhai D.	Construction & Standardization of test of Literary Creativity in Hindi for the Students of Secondary School	2008	Dr. J. H. Pancholi
2	Trivedi Bipinchandra K.	An Empirical Study of Primary Education of Border Area in Gujarat	2008	Dr. J. H. Pancholi
3	Gupta Shailendrakumar	Construction & Standardization of Self Regulation Inventory for Secondary School Students	2008	Dr. J. H. Pancholi
4	Shrimali	A Study of Decision Making and	200	Dr. J. H.

	Nareshkumar K.	Creativity of Higher Secondary Students	9	Pancholi
5	Patel Nipal D.	A Comprehensive Study between Government /Grant-in-aid P.T.C. Colleges and Self-Finance P.T.C. Colleges of Gujarat State in Context to some Variables	200 9	Dr. J. H. Pancholi
6	Patel Bhavana M.	A Comparative Study of Educational Thoughts of Swami Vivekanand & J. Krishnamurti	200 9	Dr. J. H. Pancholi
7	Prajapati Naran P.	Construction & Standardization of a Verbal -non Verbal Interest Inventory for Upper Primary School Students	200 9	Dr. J. H. Pancholi
8	Joshi Jayaram B.	A Study of the Teacher Aptitude of North Gujarat Primary Teachers' Training Institution Students and Primary Teachers and the Teacher Effectiveness of Primary Teachers	200 9	Dr. J. H. Pancholi
9	Patel Hasumati K.	Construction & Standardization of the Commitment Scale for the Secondary School Teacher	200 9	Dr. J. H. Pancholi
10	Sharma Latakumari D.	Construction & Standardization of Emotional Intelligence Test for the Students of Higher Secondary School	200 9	Dr. J. H. Pancholi
11	Patel Kanjibhai V.	Construction & Standardization of Aptitude Test for Primary School Students of 8 to 10 Agegroup	201 0	Dr. J. H. Pancholi
12	Trivedi Avaniben	A Comparative Study of Conventional Education System (CES) and Distance Education System (DES) - (With reference to higher education)	201 0	Dr. J. H. Pancholi
13	Oza Nisad	Construction & Standardization of a Spiritual Test for the Students of Higher Secondary Schools	201 0	Dr. J. H. Pancholi
14	Thakar Kamendu R.	Effect of Yoga on Educational Achievement, Mental Development and Physical Health of Secondary School Students - A Study	201 0	Dr. J. H. Pancholi
15	Joshi Jayna K.	Construction & Standardization of English Speaking Anxiety Reduction Programme for the Secondary School Students	201 0	Dr. J. H. Pancholi
16	Patel Shanta H.	A Study of the Enrollment, Shala Praveshotsav and Retention of the	201 0	Dr. J. H. Pancholi

		Admissible Children of the Primary Schools of Mehsana District		
17	Patel Khushbu P.	Construction & Standardization of Emotional Intelligence Scale for the Secondary School Students of Gujarat State	2010	Dr. J. H. Pancholi
18	Yadav Kusum R.	Effectiveness of English Communication Skill Development Program for the Secondary School Students of Gujarati Medium	2010	Dr. J. H. Pancholi
19	Damor Savita J.	Effectiveness of Gordon's Synectics Model for the Development of Creative Expressions in Gujarati Language of the Pupils of Secondary School	2011	Dr. J. H. Pancholi
20	Patel Bindu R.	Construction and Standardization of Spatial Aptitude Test for Secondary School Students	2012	Dr. J. H. Pancholi
21	Soni Kunjan L.	Effect of Personality and Creativity on Decision Making of Higher Secondary Students.	2012	Dr. J. H. Pancholi
22	Thakar Paresha H.	Construction and Standardization of Adjustment inventory for Secondary School Students	2012	Dr. J. H. Pancholi
23	Thakkar Sunil M.	An inquiry in to the Causes of Low Result in Social Science at S.S.C. Examination	2012	Dr. J. H. Pancholi
24	Thakkar Ashok S.	Construction and Standardization of English Language Proficiency Test for Higher Secondary School Students	2013	Dr. J. H. Pancholi
25	Parmar Mrudula R.	A Study of the Impact of Emotional intelligence and Spiritual Intelligence on Personality and Educational Achievement of the Students of Standard 11 th	2013	Dr. J. H. Pancholi
26	Trivedi Manojkumar Chandulal	Construction and validation of the Computerized Criterion - Referenced Test for the Organic Chemistry of 12 th Standard Students	2014	Dr. J. H. Pancholi
27	Raval Bhanushankar Prabhulal	Stress Management And Performance Of School Headmaster	2014	Dr. J. H. Pancholi

b) from other institutions/universities –

40. Number of post graduate students getting financial assistance from the university.
: Children of the university employee are getting financial assistance by way of wavier of fee

Course Name	Number of students
M.Ed.	08
M.Phil.	02
M.A.(Education)	04

41. Was any need assessment exercise undertaken before the development of new programme(s)? If so, highlight the methodology. M.A.(Education)
Yes. On the bases of telephonic inquiry, personal inquiry and written applications of the students and parents.

42. Does the department obtain feedback from
faculty on curriculum as well as teaching-learning-evaluation? If yes, how does the department utilize the feedback? Yes
students on staff, curriculum and teaching-learning-evaluation and how does the department utilize the feedback? Yes
alumni and employers on the programmes offered and how does the department utilize the feedback? Yes

43. List the distinguished alumni of the department (maximum 10)

No	Alumni of Department	Designation & Address
1	Dr. Bipinchandra K. Trivedi	Secretary, State Examination Board, Gandhinagar
2	Dr. Girishbhai P. Raval	Principal, B.D. Shah College of Education, Modasa
3	Dr. Avaniiben Trivedi	Deputy Director, IGNOU, Rajkot Regional officer
4	Dr. Jayna K. Joshi	Assistant Professor, Dept. of Education, H.N.G.U., Patan
5	Dr. Shailendrakumar Gupta	Prof. & Registrar, Carlox Uni., Ahmedabad
6	Dr. Kamendu R. Thakar	Assi. Prof., College of Education, Dabhoi
7	Dr. K.V. Patel	Ex. Principal, Experimental High School, Patan (President award Winner for best Principal)
8	Ramesh Makani	Principal, Pundhara High School, Pundhara

		GPSC(DEO) Exam Pass
9	Dr.Mahesh Solanki	DIET, Patan
10	Sharmistha Parmar	DIET, Mahesana

44. Give details of student enrichment programmes (special lectures / workshops / seminar) involving external experts.:
 Research Workshop, NET/GSET/TAT/TET examination preparation
45. List the teaching methods adopted by the faculty for different programmes.
 Group Discussion, Team Teaching, Lecture, Brain Storming, Assignment, Self-Learning etc...
46. How does the department ensure that programme objectives are constantly met and learning outcomes are monitored?
 On the bases of evaluation, result and placement, Feedback From Students Alumni & Parents
47. Highlight the participation of students and faculty in extension activities.
 AIDS Awareness program
 Women Empowerment program
 Youth Shibir
 Tree Plantation
 Teacher's Day
48. Give details of "beyond syllabus scholarly activities" of the department:-
 Counseling, Guidance, Psychological Testing
49. State whether the programme/ department is accredited/ graded by other agencies?
 If yes, give details. : N.A.
50. Briefly highlight the contributions of the department in generating new knowledge, basic or applied. N.A.
51. Detail five major Strengths, Weaknesses, Opportunities and Challenges (SWOC) of the department.

Strengths:

Qualified & Experienced Staff, Research & Projects in different new areas of Education, Placement, Sufficient Infrastructure, Dedicated Students

Weaknesses: Self – Finance Course (Department),
 Students are weak in English (Speaking, Writing and reading)

Opportunities: Centre for research in Education, Centre for excellence in Education, Interdisciplinary Courses

Challenges: students attendance (other colleges run without any attendance of the students), Due to this reason quality decreases, Lack of Interest of Students in M.Ed.

52. Future plans of the department:

Preparation of Research Abstract

Developing Psychological Test Bank

Establishment of counseling centre

* * * * *

Department of Journalism & Mass Communication

1. Name of the Department: Department of Journalism & Mass Communication
2. Year of establishment: 2002-03
3. Is the Department part of a School/Faculty of the university?
The Department is post graduate department of university
4. Names of programmes offered (UG, PG, M.Phil., Ph.D., Integrated Masters; Integrated Ph.D., D.Sc., D.Litt., etc.)
PG: Master in Journalism & Mass Communication, M. Phil (Journalism)
5. Interdisciplinary programmes and departments involved
No interdisciplinary programmes.
6. Courses in collaboration with other universities, industries, foreign institutions, etc.
Nil
7. Details of programmes discontinued, if any, with reasons:
No programmes being discontinued
8. Examination System: Annual/Semester/Trimester/Choice Based Credit System
Semester system with Choice Based Credit System
9. Participation of the department in the courses offered by other departments
No participation in the courses offered by the other departments
10. Number of teaching posts sanctioned, filled and actual (Professors/Associate Professors/Asst. Professors/others)

	Sanctioned	Filled	Actual including CAS and MPS
Professor	-	-	-
Associate Professor	-	-	-
Assistant Professor	01	01	-
Other	-	-	-

11. Faculty profile with name, qualification, designation, area of specialization, experience and research under guidance

Name	Qualification	Designation	Specialization	No. of Years of Experience	No. of Ph.D./M.Phil. students

Dr. Manoj Lodha	MJMC Ph.D	Ass. Prof.	Media	10+	guided for the last 4 years 15
-----------------------	-----------	------------	-------	-----	---

12. List of senior Visiting Fellows, adjunct faculty, emeritus professors
Experts from various Newspaper organisation, TV agencies, radio station are visiting the department regularly as visiting faculty.
13. Percentage of classes taken by temporary faculty – programme-wise information:
15%
14. Programme-wise Student Teacher Ratio
P.G.Programme -1:10
15. Number of academic support staff (technical) and administrative staff:
sanctioned, filled and actual - 01 Clerk
02 Peon
16. Research thrust areas as recognized by major funding agencies
Nil
17. Number of faculty with ongoing projects from a) national b) international funding agencies and c) Total grants received. Give the names of the funding agencies, project title and grants received project-wise.
Nil
18. Inter-institutional collaborative projects and associated grants received
a) National collaboration b) International collaboration
No such collaboration
19. Departmental projects funded by DST-FIST; UGC-SAP/CAS, DPE; DBT, ICSSR, AICTE, etc.; total grants received.
No such project
20. Research facility / centre with
 - state recognition - No
 - national recognition - No
 - international recognition - No
21. Special research laboratories sponsored by / created by industry or corporate bodies
No such creation

22. Publications: -
- Number of papers published in peer reviewed journals (national / international)
Nil
 - Monographs - Nil
 - Chapters in Books - Nil
 - Edited Books - Nil
 - Books with ISBN with details of publishers - Nil
 - Number listed in International Database (For *e.g.* Web of Science, Scopus, Humanities International Complete, Dare Database - International Social Sciences Directory, EBSCO host, etc.) - Nil
 - Citation Index – range / average – Nil
 - SNIP - Nil
 - SJR - Nil
 - Impact Factor – range / average - Nil
 - h-index - Nil
23. Details of patents and income generated -Nil
24. Areas of consultancy and income generated
25. Faculty selected nationally / internationally to visit other laboratories / institutions / industries in India and abroad -Nil
26. Faculty serving in -
- a) National committees
 - b) International committees
 - c) Editorial Boards
 - d) any other (please specify) Nil
27. Faculty recharging strategies (UGC, ASC, Refresher / orientation programs, workshops, training programs and similar programs). - Nil
28. Student projects -
- percentage of students who have done in-house projects including inter-departmental projects - Nil
 - percentage of students doing projects in collaboration with other universities / industry / institute - Nil
29. Awards / recognitions received at the national and international level by -
- Faculty - Nil
 - Doctoral / post doctoral fellows - Nil
 - Students - Nil
30. Seminars/ Conferences/Workshops organized and the source of funding (national / international) with details of outstanding participants, if any. - Nil

31. Code of ethics for research followed by the departments
The department follows code of ethics in research.

32. Student profile programme-wise:

Name of the Programme (refer to question no. 4)	Applications received	Selected		Pass percentage	
		Male	Female	Male	Female
2012-13 MJMC	14	8	1	88.88	100
2013-14 MJMC	13	11	2	90.90	50
2012- 2013 MPHIL	4	4	-	100	-
2013-14 M.PHIL	3	1	2		

33. Diversity of students

Name of the Programme (refer to question no. 4)	% of students from the same university	% of students from other universities within the State	% of students from universities outside the State	% of students from other countries
2012-13 MJMC	50	50	-	-
20103-14 M.JMC	90	-	-10	-
20113-14 MPHIL	100	-	-	-
2013-13 4 MPHIL	100	-	-	-

34. How many students have cleared Civil Services and Defense Services examinations, NET, SET, GATE and other competitive examinations? Give details category-wise.

Nil

35. Student progression

Student progression	Percentage against enrolled
UG to PG	100%
PG to M.Phil.	-
PG to Ph.D.	-
Ph.D. to Post-Doctoral	-

Employed	
<input type="checkbox"/> Campus selection	-
<input type="checkbox"/> Other than campus recruitment	-
Entrepreneurs	

36. Diversity of staff

Percentage of faculty who are
 graduates of the same university Nil
 from other universities within the State Nil
 from universities from other States 100 %
 universities outside the country Nil

37. Number of faculty who were awarded M.Phil., Ph.D., D.Sc. and D.Litt. during the assessment period - Nil

38. Present details of departmental infrastructural facilities with regard to
 a) Library - No departmental library. Students access university library
 b) Internet facilities for staff and students: available
 c) Total number of class rooms: 03
 d) Class rooms with ICT facility: 01
 e) Students' laboratories: Nil
 f) Research laboratories : Nil

39. List of doctoral, post-doctoral students and Research Associates
 a) from the host institution/university: Nil
 b) from other institutions/universities: Nil

40. Number of post graduate students getting financial assistance from the university.
 Nil

41. Was any need assessment exercise undertaken before the development of new programme(s)? If so, highlight the methodology.
 No

42. Does the department obtain feedback from
 a. faculty on curriculum as well as teaching-learning-evaluation? If yes, how does the department utilize the feedback?
 b. students on staff, curriculum and teaching-learning-evaluation and how does the department utilize the feedback?
 c. alumni and employers on the programmes offered and how does the department utilize the feedback?

43. List the distinguished alumni of the department (maximum 10)
44. Give details of student enrichment programmes (special lectures / workshops / seminar) involving external experts.
45. List the teaching methods adopted by the faculty for different programmes. Seminar, Group Discuss Lecture.
46. How does the department ensure that programme objectives are constantly met and learning outcomes are monitored?
47. Highlight the participation of students and faculty in extension activities. Youth Festival, National Seminar Participation, Quiz Compaction.
48. Give details of “beyond syllabus scholarly activities” of the department. - NIL
49. State whether the programme/ department is accredited/ graded by other agencies? If yes, give details. NO
50. Briefly highlight the contributions of the department in generating new knowledge, basic or applied. Nothing new being Developed.
51. Detail five major Strengths, Weaknesses, Opportunities and Challenges (SWOC) of the department. 1. Faculty Strengths is Weak Point
2. IT Faculty is less
52. Future plans of the department.
 1. To Start the M.Phil Programme

Evaluative Report of the Department of Law

1. Name of the Department : Department of law
2. Year of establishment : 2003 – 2004
3. Is the Department part of a School/Faculty of the university?
➤ Faculty of University
4. Names of programmes offered (UG, PG, M.Phil., Ph.D., Integrated Masters; Integrated Ph.D., D.Sc., D.Litt., etc.)
➤ PG(LL.M-Criminal Law Group & Business Law Group), M.Phil, Ph.D
5. Interdisciplinary programmes and departments involved :- NIL
6. Courses in collaboration with other universities, industries, foreign institutions, etc.
➤ Nil
7. Details of programmes discontinued, if any, with reasons
➤ Nil
8. Examination System: Annual/Semester/Trimester/Choice Based Credit System
➤ Choice Based Credit System
9. Participation of the department in the courses offered by other departments :----
10. Number of teaching posts sanctioned, filled and actual (Professors/Associate Professors/Asst. Professors/others)

	Sanctioned	Filled	Actual (Including CAS& MPS)
Professor			
Associate Professor			
Asst. Professor	01	01	
Others	02	02	

11. Faculty profile with name, qualification, designation, area of specialization, experience and research under guidance

Name	Qualification	Designation	Specialization	No. of Years of Experience	No. of Ph.D./ M.Phil. students guided for the last 4 years
Dr. Smita B. Vyas	LL.M , Ph.D	Asst.Proff. & Co-Ordinator	Criminal Law	U.G–5Years, P.G–9 Years.	Ph.D – 4, M.Phil – 15
Dr. Hemant K. Patel	LL.M, M.Phil, Ph.D	Teaching Asst.	Criminal Law	U.G– Years, P.G–3 Years.	--
Dr. Rekhaben M. Patel	LL.M, M.Phil, Ph.D	Teaching Asst.	Criminal Law	U.G.-1 Year, P.G.- 4Years.	--

12. List of senior Visiting Fellows, adjunct faculty, emeritus professors

Name of Faculty	Designation
Dr. J.U. Nanavaty	Principal Sheth M.N. Law College Patan
Dr. N.S. Vyas	Asst. Proff.
Dr. K.C. Patel	Asst. Proff.
Dr. K.T. Chadokia	Asst. Proff.

13. Percentage of classes taken by temporary faculty – programme-wise information
- In LL.M Program 40% of classes taken by temporary faculty
 - In M.Phil Program 10% of classes taken by temporary faculty

14. Programme-wise Student Teacher Ratio :-

- LL.M :- 56 : 1 (1 Teacher have 56 student in LL.M ratio in this academic year)
- M.Phil :- 4 : 1 (1 Teacher have 4 student in M.Phil ratio in this academic year)

15. Number of academic support staff (technical) and administrative staff: sanctioned, filled and actual

- 1 - Clerk
- 1 – Peon

16. Research thrust areas as recognized by major funding agencies

- Major thrust area suppose to be recognize by Agencies such like as below..
 1. Royal castrol
 2. Multi Gas Company

3. Unjha Formulation

17. Number of faculty with ongoing projects from a) national b) international funding agencies and c) Total grants received. Give the names of the funding agencies, project title and grants received project-wise.
- Nil
18. Inter-institutional collaborative projects and associated grants received
- a) National collaboration b) International collaboration
- There are no any National & Institutional collaborative and associated grant Received.
19. Departmental projects funded by DST-FIST; UGC-SAP/CAS, DPE; DBT, ICSSR, AICTE, etc.; total grants received.
- Dr. Smita B. Vyas – 80,000 Funded by UGC
- Dr. Hemant K. Patel – 80,000 Funded by UGC
20. Research facility / centre with :- -----
- state recognition
 - national recognition
 - international recognition
21. Special research laboratories sponsored by / created by industry or corporate bodies
- Nil
22. Publications:
- Number of papers published in peer reviewed journals (national /international) :-
- All Faculties National and International Paper published as below
1. Dr.Smita B.Vyas

Sr. No.	Name of Articles	Magazine/Journal	Year & Vol. of publication
1.	Consumer Protection on Gold in India	Guj.High. Judgement	Page No.185 Jan'08 to Feb'08
2.	મૃત્યુદંડથી માનવ અધિકારનો ભંગ થતો નથી.	Guj.High. Judgement	Page.No.JS-126 April 2008
3.	કોપીરાઈટના ભંગ બદલ દિવાની ઉપચારો	Guj.High. Judgement	Page No.27 May-2008
4.	મહિલા કાનૂની શિક્ષણ	Guj.High. Judgement	Page No.29 May-2008
5.	બાળમજૂરી: શૈક્ષણિક અભિગમ	યોજના	Page No.98 May 2008

			ISSN-0971-8400
6.	Dowry in India: There are commas, not full stop	Guj.High. Judgement	Page No.98 Aug. 2008
7.	Medical Negligence and Consumer's rights	Guj.High. Judgement	Page No.81 July 2008
8.	વિકાસનો હકક: એક વૈશ્વિક પડકાર	Guj.High. Judgement	Page No.78 July 2008
9.	બાળકોનો હકક જન્મયા પહેલા	યોજના	Page No.10 Nov. 2008 ISSN-0971-8397
10.	Social Aspects of Consumer Protection	Journal of Law – A Govt. of Guj. Publication	Page No. 43 2010
11.	Global Warming and Sustainable Development: A Judicial Approach	University News	Page No.149 June 2010 ISSN – 0566-2257
12.	Environmental, Development and Human Rights: Integrated Approach to Civil Society	“ઉદ્ગમ A Research Journal- Sheth M.N. Law College, Patan	Page No.- 17 Vol. 2-2011 ISSN-2230-7478
13.	Environmental Consumerism	Law Z	Page No. 28 July 2011
14.	Consequences of Registration of Marriage	ઉદ્ગમ A Research Journal- Sheth M.N. Law College, Patan	Page No.-45 Vol. 3-2012 ISSN-2230-7478
15.	Entry of Foreign Legal Consultants and Foreign Law Firms into India	Saurashtra Uni. Law Journal	Page No. 53 Feb. 2012
16.	Hindu woman's Property Rights:A Gender Justice Perspective	Journal Of Indian Legal system Saurashtra Uni.	ISSN-2277-4254 2012
17.	Environmental Issues under Consumer Law	Journal of Law, Forensic Science and Social Studies	Page No.86 2012 ISSN 2277-4971
18.	Position of Child Labour in Unorganized Sector	ઉદ્ગમ A Research Journal- Sheth M.N. Law College, Patan	Page No.-50 Vol. 4-2013 ISSN-2230-7478
19.	Human Rights Of the Child: The Indian Perspective	Saurashtra Uni. Law Journal	ISSN-2277-6044 2013
20.	Environment, Development and	Adhikar Chetna	ISSN-2278-1856

Human Rights : Integrated Approach to Civil Society	(Law College Palanpur)	Vol.-3(2013) page - 43
---	------------------------	---------------------------

2. Dr. Rekhaben. M. Patel

Sr.	Name of Articles	Magazine/Journal	Year & Vol.
1	પ્રવર્તમાન સમયમાં મહિલાઓની સામાજીક સમસ્યા	અમદાવાદ લો-ટાઈમ્સ	August- 2010 Page No. A – 89
2	“ The Problem of Prostitution An Indian Perspective”	અમદાવાદ લો-ટાઈમ્સ	1 st August- 2010 Page No. A – 92
3	“ સ્ત્રીભૂષણ હત્યા એક મુંગી ચીસ ”	અમદાવાદ લો-ટાઈમ્સ	2010 Volume-1 Page No. A-105
4	“New Challenges to the legal Education in India”	અમદાવાદ લો-ટાઈમ્સ	November - 2010 Page-No. A 123
5	“ બાળકોના સમગ્ર વિકાસના સંદર્ભમાં આજનું શિક્ષણ ”	આપણો અધિકાર ન્યાય દર્શન, બરોડા	October -2010 Page No.- 23
6	“Value Education in Higher Education”	અમદાવાદ લો-ટાઈમ્સ	August-2011 Page No. – 25
7	“ સામાજીક સમસ્યા અને અસ્પૃશ્યતા નિવારણ ”	Social Welfare Dept. Guj. State Gandhinagar Deprt. Of Social Works and Dr. Babasaheb Amedkar Chair H.N.G.U.Patan	4-5 March -2008 Page No. 14
8	“Politics and Imperial Presentation on Judiciary”	Udgam A Research Journal	2011 Valume-2
9	“ Uchha Shishan ma mulya shikshan ni Avshakta” in State level Seminar Spencer by UGC and PATAN	-	27 Feb - 2011
10	“Mass Media : The Rapidly Expanding Service”	Udgam A Research Journal	2013 ISSN 2230-7478 Valume-4
11	“ નવતર – સેવાક્ષેત્ર – માહિતીનું અર્થશાસ્ત્ર ”	યોજના	યોજના –૨૦૧૧ સપ્ટેમ્બર પેજ નં. – ૩૧
12	“ મફત અને ફરજિયાત શિક્ષણનો હકક ”	યોજના	April-2013 Page No. 43
13	“Dishonor of Cheque”	Saurashtra University Gujarat.	LawJournal Volume-2 ISSN 2277-6044 Feb. 2013
15	Protection of copy rights in digital age	Udgam A Research Journal	ISSN 2230-7478 VOL-5,2014

1. Dr.Smita B.Vyas

Sr. No.	Title of Book	Name of Publishers	Year
1.	DFGJ VIWSFZMGM jIF5 VG[VFTZZFQ8=LI SFINFVM ISBN-978-93-5126-963-2	GLZJ 5 SFXG4 VDNFJFN	2014
2.	Consumer Protection ISBN: 978-93-5032-021-1	Shree Niwas Publications, Jaipur	2012
3	Women at Work (Issues and Challenges) ISBN:978-93-5032-061-7	Shree Niwas Publications, Jaipur	2013
4	Fundamentals: Research Through Internet ISBN:978-93-5032-062-4	Shree Niwas Publications, Jaipur	2013

2. Dr.Rekhaben M. Patel

Sr.No.	Title of Book	Name of Publishers	Year
1	Public interest litigation in India ISBN : 13 : 978-81- 922326-3-8	J.P. Publication	2011
2	Business law (Gujarati) ISBN 13-978-81- 922326-2-1	J.P. Publication	2011
3	HRM & Marketing Management ISBN-13-979-81- 922326-1-4	J.P. Publication	2011
4	Business Management ISBN 13 : 978-81- 922326-0-7	J.P. Publication	2011
5	Awareness of Consumer Projection Act. ISBN 13 : 978-81- 922326-4-5	J.P. Publication	2011
6	Business Law (English)	J.P. Publication	2012

3.Dr.Hemant K. Patel

Sr. No.	Title of Book	Name of Publishers	Year
1.	Dalits and Human Rights ISBN-9788122006963	Shreeya Publications	2009
2.	Banking and Finance	Shreeya Publications	2010

	ISBN-9788122006901		
3.	Globalization and Indian Foreign Policy ISBN-9788192006970	Shreeya Publications	2010
4.	Indian Structure and Social Change ISBN-9788192006987	Shreeya Publications	2011
5.	Principal and Methods of Public Administration ISBN-9788192006994	Shreeya Publications	2011
6.	M.C.Q. Question Bank Second Year LL.B. ISBN-9788192350639	Saurashtra Uni., Rajkot.	2012
7.	M.C.Q. Question Bank Third Year LL.B. ISBN-978-93-5104-441-3	Saurashtra Uni., Rajkot.	2013

- Number listed in International Database (For *e.g.* Web of Science, Scopus, Humanities International Complete, Dare Database - International Social Sciences Directory, EBSCO host, etc.) :- Nil
 - Citation Index – range / average :- Nil
 - SNIP :- Nil
 - SJR :- Nil
 - Impact Factor – range / average
 - h-index
23. Details of patents and income generated:- Nil
24. Areas of consultancy and income generated :- Nil
25. Faculty selected nationally / internationally to visit other laboratories / institutions industries in India and abroad :-Nil
26. Faculty serving in
- a) National committees b) International committees c) Editorial Boards d) any other (please specify):-
- Dr.Smita B. Vyas:-
1. Member of Board of Studies, H.N.G.Uni., Patan.
 2. Member of Board of Studies,(Jurisprudence) Sau.Uni, Rajkot
 3. Member of Selection Committee of Tracking, H.N.G.Uni., Patan.
 4. Member of Sexual Harassment Committee, H.N.G.Uni., Patan.
 5. Member of ‘Day Care Center’, H.N.G.Uni., Patan.
 6. Member of ‘Student Initiative Committee’.
 7. Member of ‘Grievance Redressal cell.’

8. Associate Proctor in University Proctorial Board.
9. Member of 'Taluka Legal Service Committee of Patan District'
10. Member of 'Committee Against Sexual Harassment(CASH)'
11. Member of International Committee WILPF(women International league for peace and Freedom)

➤ Dr.Hemant K.Patel:-

1. Member of Board of Studies,(Jurisprudence) Sau.Uni, Rajkot

➤ Dr.Rekhaben M. Patel:-

1. Member of 'Taluka Legal Service Committee of Patan District'
2. Member of 'Committee Against Sexual Harassment(CASH)'
3. Member of International Committee WILPF(women International league for peace and Freedom)

27. Faculty recharging strategies (UGC, ASC, Refresher / orientation programs, workshops, training programs and similar programs).

1. Dr.smita B. Vyas

Sr.No.	Subject Name	Sponsored	Organised College/ Department	Seminar/ Workshop	Date
1	Conflict Between Judiciary and Legislation.	UGC	Sheth M.N.Law College, Patan.	State Level Seminar (Paper Presented)	31 st Jan., 2009
2	Human Rights And Value Education: Sensitization, Concept and Challenges	UGC	Department of Human Rights and International Humanitarian Laws, Saurashtra Uni. Rajkot.	National Seminar (Paper Presented)	3 rd -5 th Oct., 2009
3	Uniform Syllabus	Department of Law	Saurashtra Uni. Rajkot.	State Level Seminar	8 th October 2009
4	With Book Examination	Department of Law	Saurashtra Uni. Rajkot.	State Level Seminar	9 th October 2009
5	Information Technology Laws and related Intellectual Property	Faculty of Law	Uni. of Delhi and Dept. of Information Technology, Govt. of India	Workshop-cum-Conference	19 to 21, March, 2010

6	Law, Disabled & Human Rights and Duties Education	UGC	Jainarayan Vyas Uni., Jodhpur	National Seminar (Paper Presented)	4 th to 6 th Sep. 2010
7	Human Rights and Human Development: Futuristic Role of Teacher Education	UGC	N.H. Patel College of Education, Anand	National Level Seminar (Paper Presented)	25 th Sep., 2010.
8	Importance of Legal Education in 21 st Century		Sheth V.S. Law College, Unjha.	National Workshop (Delivered key note address)	3 rd Oct., 2010
9	Capacity Building Workshop	KCG, Dept of Education	HNGU, Patan	Workshop	15 th Oct., 2010
10	Research Initiative	Dept of Life Science	HNGU, Patan	Workshop	21 st Oct., 2010
11	CBCS and Internal Evaluation Workshop	HNGU, Patan	HNGU, Patan	Workshop	20 th Nov., 2010
12	Themes of Higher Education: Prospects of Gujarat	Govt. of Guj.	KCG, Dept of Edu. & P.D. Petroleum Uni., Gandhinagar	International Conference	25 th & 26 th Nov., 2010
13	Management of Higher Education in the Gujarat State	Govt. of Gujarat	H.N.G.Uni., Patan.	Workshop	10 th Dec., 2010.
14	Criminalization of Politics; a Serious threat to our democracy	UGC	Sheth M.N.Law college, Patan.	National Workshop (Chaired the Session)	8 th -9 th Jan., 2011
15	Research Marathon	UGC	H.N.G.Uni., Patan.	Research Initiative,	10 th -12 th Jan., 2011.

				Phase-II Workshop (Proposal Presented)	
16	Hospital & Healthcare Management Emerging Trends, Issues and Challenges	Dept. of Health & Family Welfare, Govt. of Guj.	Dept. of Hospital Management, HNGU, Patan	National Conference	26 th Mar.,2011
17	Creating Excellence for Sustainable Society	HNGU, Patan	HNGU, Patan	International Seminar (Poster Presentation)	15-16 May, 2011
18	Technology and Society: Issues and Challenges	Rajiv Gandhi National Institute of Youth Development(RGNIYD) & UGC	Indian Sociological society & Hem. N.G.Uni., Patan.	Workshop	26 th -27 th Sep., 2011.
19	Research Methodology: A March towards creating Research culture	Association of Indian Universities, KCG Gandhinagar,NAAC Banglore	H.N.G. Uni, Patan	National Workshop	21 to 24 Nov 2011
20	Orientation & Planning meet	KCG Gandhinagar	Ahmedabad Management Association Ahmedabad	Workshop	25 & 26 June 2012
21	Research Methodology in Legal inter disciplinary field	GNLU, Gandhinagar	GNLU, Gandhinagar	National Workshop	5 th Sep to 9 th Sep 2012
22	Human Rights on Industrial Labour in 21 st Century	The M.L. Gandhi Higher Education Society, Modasa	Shri N.S. Patel Law College, Modasa	National Seminar (Paper Presented) & Chaired the Sesson	13&14 Oct, 2012.

23	Law and Challenges in 21 st century: special reference to Women	UGC	School of Law Gujarat University Ahmedabad	National Seminar Paper Presented	20/01/2013
24	Enhancing The Standards of Legal Education : The Roll and Responsibilities of Stakeholders	Gujarat University	School of Law Gujarat University Ahmedabad	National Seminar Paper Presented	20/10/2013

2. Dr. Rekhaben M. Patel

Sr .	Subject Name	Sponsor	Organised College/Department	Seminar/Workshop	Date
1	“ Conflict Between Judiciary and Legislation	UGC	Sheth M.N.Law Collage, PATAN	State Level Seminar	31th Jan. 2009
2	Child labour problems in present times	Guj. State Govt.	Yoganjali Ashram Sidhpur	State Level Seminar	14 th Nov. 2009
3	Woman’s Rights and Human Rights		Bhagini Samaj	State Level Seminar	27 th Sep. 2009
4	Changing status of Women in 21th Century.		Palanpur Law Collge	State Level Seminar	23th Sep. 2011
5	Women Social Problem in present time	UGC	Unjha Mahila college,	State Level Seminar	24 th Nov. 2011
6	Value Education in Higher Education	UGC		State Level Seminar	27 th Feb. 2011
7	Woman Empowerment	Silver Jubilee Celebrati	HNGU,PATAN	State Level Seminar	7 th March 2011

		on of HNGU.			
8	One day Seminar on Woman Empowerment”	UGC	H.N.G.U.	State Level Seminar	6 th March 2012
9	Teaching and Research in Law Org.by IBA CLE, National Law School of India University and Memon Institute of legal Advocacy Training At. Institute of Law Nirma University	Nirma University	Ahmedabad	State Level Seminar	2 nd to 11 th January, 2013

3. Dr. Hemant K. Patel

Sr.No.	Subject Name	Sponsored	Organised College/ Department	Seminar/ Workshop	Date
1	21 st Century Human Rights and Education	UGC	C.B.Patel Arts College, Nadiad.	National Seminar	24 th -25 th Jan., 2009.
2	Conflict Between Judiciary and Legislation.	UGC	Sheth M.N.Law College, Patan.	State Level Seminar	31 st Jan., 2009
3	Electoral Reforms	UGC	Department of Law, Saurashtra Uni. Rajkot.	National Seminar	22 nd Mar. 2009
4	Legal Research Methodology	UGC	Anand Law College, Anand.	State Level Workshop	3 rd Oct., 2009
5	User Awareness Programme on E-resources (UGC-Infonet)	UGC	Shivabhai Umedbhai Library, Hem. North Guj. Uni. Patan.	Seminal	26 th Nov., 2009
6	Labour Laws in	Mahatma	Mahatma Gandhi Labour	National	20 th Mar.,

	21 st Century	Gandhi Labour Institute, Ahmedabad. (An Autonomous Institute of the Govt. of Guj.)	Institute, Ahmedabad.	Seminar	2010.
7	Roadmap for Implementation of Credit Based course in Law Syllabi	I.M.Nanavati Law College, Ahmedabad	I.M.Nanavati Law College, Ahmedabad	State Level Seminar	5 th Sep., 2010
8	Importance of Legal Education in 21 st Century	Sheth V.S.. Law College, Unjha.	Sheth V.S.. Law College, Unjha.	National Workshop	3 rd Oct, 2010.
9	Human Rights And Value Education: Sensitization, Concept and Challenges	UGC	Centre of Human Rights and International Humanitarian Laws Bhavnagar Uni., Bhavnagar.	National Seminar (Paper Presented)	13-15 th Nov., 2010
10	Management of Higher Education in the Gujarat State	Govt. of Gujarat	H.N.G.Uni., Patan.	Workshop	10 th Dec., 2010.
11	Right to Information Act, 2005 at a glance	H.N.G.Uni., Patan.	Department of Law, H.N.G.Uni., Patan.	Workshop	28 th Dec. 2010.
12	All Gujarat Law Teachers' Training Programme	Commission-erate of Higher Education Dept., Govt., of Gandhinagar.	Commission-erate of Higher Education Dept., Govt., of Gandhinagar & G.N.L.U. Gandhinagar.	Training Programme	29 th Dec., 2010

13	Criminalization of Politics; a Serious threat to our democracy	UGC	Sheth M.N.Law college, Patan.	National Workshop	8 th -9 th Jan.,2011
14	Research Marathon	UGC	H.N.G.Uni., Patan.	Research Initiative, Phase-II Workshop (Proposal Presented)	10 th -12 th Jan., 2011.
15	Secularism & Law	UGC	Department of Law, Saurashtra Uni. Rajkot.	National Workshop	19 th Feb. 2011.
16	Human Rights in 21 st Century: Changing Dimensions	Uni.Of Delhi	Faculty of Law, Uni. of Delhi.	International Conference	25 th -26 th Feb.,2011.
17	Trade & Competition Law	GNLU., Gandhinagar	GNLU., Gandhinagar	International Conference	5 th -6 th Mar., 2011.
18	Regional Level CBCS MCQ Question Bank Workshop	Saurashtra Uni. Rajkot.	Faculty of Law, Saurashtra Uni. Rajkot.	Workshop	18 th Mar., 2011.
19	Sardar Patel & Dr. Babasaheb Ambedkar: Contemporary Relevance	UGC Sponsored	H.M.Patel Institute of English Training & Research, Charutar Vidya Mandal Vidhyanagar	National Level Seminar	11 th & 12 th August, 2011.

20	Technology and Society : Issues and Challenges	Rajiv Gandhi Institute of Youth Development & UGC	Indian Sociological Society and Hem.North Gujarat University Patan	All India Young Social Scientists Workshop	26-27 Sep.2011
21	Research Methodology : A March Towards Creating Research Culture	Hem.North Gujarat University Patan	Ass of Indian Uni . New Delhi & Kno.con of Guj.Gandh & Hem.Nor.Guj.Uni.Patan & Nat.Ass & Acc. Cou. Bang	National Workshop	21-24 Nov 2011
22	Human Right Education –A Socio-Legal Perspective	UGC Sponsored	M.S Bhagat & C.S. Sonawala Law College,Nadiad	National Workshop	24 th ,Dec 2011
23	5 th Annual Intellectual Property Summit 2012	Ahmedabad Management Association	Y.J.Trivedi – AMA Academy for Intellectual Property Right	International Conference	7 th & 8 th Jan 2012
24	Constitution of India	Guj. National Law Uni., Gandhinagar.	Guj. National Law Uni., Gandhinagar.	State Level Conference	26 th Feb. 2012
25	World Women's day	Hem. N.G.Uni., Patan.	Dept. of Law & Dept. of Social Work,	Seminar	6 th March, 2012.

26	Human Rights on Industrial Labour in 21 st Century	The M.L. Gandhi Higher Education Society, Modasa	Shri N.S. Patel Law College, Modasa	National Seminar (Paper Presented)	13&14 Oct, 2012.
27	Human rights and Ecological Balance: A Dialogue	Saurashtra Uni., Rajkot	Dept. of Human Rights and International Humanitarian Laws	National Seminar	4&5 March, 2013.
28	Enhancing the standards of Legal Education: The Role and responsibilities of Stakeholders	Gujarat University, Ahmedabad.	University School of Law, Ahmedabad.	National Seminar (Paper Presented)	20 th October

28. Student projects

- percentage of students who have done in-house projects including inter-departmental projects :- Nil
- percentage of students doing projects in collaboration with other universities / industry / institute :- Nil

29. Awards / recognitions received at the national and international level by :- Nil

- Faculty
- Doctoral / post doctoral fellows
- Students

30. Seminars/ Conferences/Workshops organized and the source of funding (national / international) with details of outstanding participants, if any.

Sr. No	Title	Duration	No. Of Participant
1	Calibration of World Women Day - 2011	1 Day	300
2	RTI ACT 2005	1 day	60
3	Learn to lead	1 day	50
4	Calibration of World Women Day - 2012	1 day	125
5	WILPF – Milan & Parisamvad	1 day	170
6	Women Self Defence Talim Shibir	3 day	50

7	“Mahila Kanuni Shibir”	3 day	58
8	RTI Seminar	1 day	200
9	Ragging: The Social problem	1 day	50
10	Word Consumer Day	1 day	20

31. Code of ethics for research followed by the departments :-
As per university norms.

32. Student profile programme-wise:

Name of the Programme (refer to question no. 4)	Applications received	Selected		Pass percentage	
		Male	Female	Male	Female
LL.M	105	76	29	72%	82%
M.Phil	13	7	6	100%	100%

Diversity of students

Name of the Programme (refer to question no. 4)	% of students from the same university	% of students from other universities within the State	% of students from universities outside the State	% of students from other countries
LL.M	70%	30%	-----	-----
M.Phil	90%	10%	-----	-----

34. How many students have cleared Civil Services and Defence Services examinations, NET, SET, GATE and other competitive examinations? Give details category-wise.

1. One Student Cleared The Exam
2. Five students are Cleared Civil Services Exam

35. Student progression

Student progression	Percentage against enrolled
UG to PG	NIL
PG to M.Phil.	-

PG to Ph.D.	3 Students
Ph.D. to Post-Doctoral	NIL
Employed	
<input type="checkbox"/> Campus selection	NIL
<input type="checkbox"/> Other than campus recruitment	100%
Entrepreneurs	NIL

36. Diversity of staff

Percentage of faculty who are graduates	
of the same university	100%
from other universities within the State	NIL
from universities from other States from	NIL
universities outside the country	NIL

37. Number of faculty who were awarded M.Phil., Ph.D., D.Sc. and D.Litt. during the assessment period

- One Faculty awarded – M.Phil & Ph.D
- One Faculty awarded – M.Phil

38. Present details of departmental infrastructural facilities with regard to

- a) Library :- No
- b) Internet facilities for staff and students :- Only For Co-Ordinator
- c) Total number of class rooms :- Four Class Rooms are available for lecture.
- d) Class rooms with ICT facility :- One Class room
- e) Students' laboratories :- ----
- f) Research laboratories :- ----

39. List of doctoral, post-doctoral students and Research Associates

a) from the host institution/university :-

Sr · N o	Name of Students	Subject
1	K.M. Upadhyaya	A Social-Legal Study of HIV Patients in Gujarat in Context to Human rights
2	Parthakji Rupa	A Legal Study on emerging Role of Independent directors in Global Corporate World
3	Y.B. Simpi	A Social-Legal Study on Corporate crime and criminal liability with reference to criminal Justice System in India-An Analytical Study.

from other institutions/universities :- NIL

40. Number of post graduate students getting financial assistance from the university.
- Although the University not given any financial assistance from university but Government give them scholar ship as par cast category
- In year 2013-14 there are total 30th students are getting Scholarship in all category(obc,sc,st,nt/dnt)
 - In year 2012-13 there are total 14th students are getting Scholarship in all category(obc,sc,st,nt/dnt)
41. Was any need assessment exercise undertaken before the development of new programme(s)? If so, highlight the methodology. :- No
42. Does the department obtain feedback from :- No
- a. faculty on curriculum as well as teaching-learning-evaluation? If yes, how does the department utilize the feedback?
 - b. students on staff, curriculum and teaching-learning-evaluation and how does the department utilize the feedback?
 - c. alumni and employers on the programmes offered and how does the department utilize the feedback?
43. List the distinguished alumni of the department (maximum 10)
1. Dr.Hareshbhai Vyas
 2. Vipul Patel

3. Dr.Arvinbhai Patel
 4. Dr.Hardik Patel
 5. Dr.Avni Aal
 6. Dr.Kinna Chadokia
 7. Maheshbhai Mulani
 8. Avnika Patel
 9. Jayprakash Jani
 10. Dr.Binalben Patel
44. Give details of student enrichment programmes (special lectures / workshops / seminar) involving external experts.
- External experts Special Lectures.
 1. Dr.B.J. Maniyar (Department of law Sau. Uni., Rajkot)
 2. Dr.M.J. Jadeja (Law College Gondal)
 3. Dr.Mayuriben Pandya(L. A. Shah Law College, Ahmedabad)
 4. Dr. Hiren Patel (Law College, Ahmedabad)
 5. Dr.Apurv Pathak (Law College, Anand)
 6. A.M. Saiyad (Lectures on The Law Super Software)
 7. Dr.Ankur Patel (Dharpur Medical Collage)
 8. P.C. Barot Superintendent Drug Department
45. List the teaching methods adopted by the faculty for different programmes.
1. Lecture Methods With use of ICT
 2. Class Room Seminar
 3. Group Discussion
 4. Case Study
46. How does the department ensure that programme objectives are constantly met and learning outcomes are monitored? :- NIL
47. Highlight the participation of students and faculty in extension activities.
1. Visit to Sabarmati jail
 2. Visit to Department of Drug
 3. Visit to Sab Jail Patan
 4. Visit to Royal Castor PVT.
 5. Visit to U – Formulation PVT. ,Unjha
 6. Visit to Multi Gas Company, Mahesana.
48. Give details of “beyond syllabus scholarly activities” of the department.
- We Arrange Industrial Visit & Educational tour
 - We Arrange Special Lectures of Experts
49. State whether the programme/ department is accredited/ graded by other agencies? If yes, give details. :- -----
50. Briefly highlight the contributions of the department in generating new

knowledge, basic or applied.

- By Organised Work Shops and Seminar just like -
 1. “Reging a Social Problem”
 2. “Mahila Kanuni Sibir”
 3. “Self Defence Training”
 4. “Right to Information”
- Celebrates a Various days Just Like—
 1. ‘Cunsumer Protection day’
 2. ‘World Water Day’
 3. ‘Teachers day’
 4. ‘International women day’

51. Detail five major Strengths, Weaknesses, Opportunities and Challenges (SWOC) of the department.

Strengths	Weaknesses	Opportunities	Challenges
All Teaching Faculty are Fully qualified	Departmental Library is not available	Appoint as a Lecturer	Poor Economical Background
Our Visiting Faculty are Fully qualified	Internet lab is not available	Serve in Corporate side	Poor Educational Background
Our Department is Only P.G. Department in North Gujarat and Kutch	There are not enough permanent faculty in our Department	Serve in Judicially side	Higher standard of fees
Only this Department having M.Phil Program in all Over Gujarat	Fees are Higher in the comparison to any Granted Department	Legal Advisor	Mostly Students are come from Rural areas.
We Have six Ph.D(Law) Guide In Our University		Legal Officer	

Future plans of the department.

- We would like to start Diploma courses Just like
 - Diploma in Human Right
 - Diploma in Environmental Law
 - Diploma in Legal Drafting

We want to Start Five Years Integrated Program With BBA,B.Com

Evaluative Report of the Department of Library & Information Science

1. Name of the Department - **Library & Information Science**
2. Year of establishment - **1992-93**
3. Is the Department part of a School/Faculty of the university? - **University**
4. Names of programmes offered (UG, PG, M.Phil., Ph.D., Integrated Masters; Integrated Ph.D., D.Sc., D.Litt., etc.) - **UG, PG, Ph.D.**
5. Interdisciplinary programmes and departments involved -
6. Courses in collaboration with other universities, industries, foreign institutions, etc. -
7. Details of programmes discontinued, if any, with reasons -
8. Examination System: Annual/Semester/Trimester/Choice Based Credit System
Semester
9. Participation of the department in the courses offered by other departments -
10. Number of teaching posts sanctioned, filled and actual (Professors/Associate Professors/Asst. Professors/others)

	Sanctioned	Filled	Actual (including CAS & MPS)
Professor	-	-	-
Associate Professors	-	-	-
Asst. Professors		01	

11. Faculty profile with name, qualification, designation, area of specialization, experience and research under guidance

Name	Qualification	Designation	Specialization	No. of Years of Experience	No. of Ph.D./ M.Phil. students guided for the last 4 years
Dr. Nilesh A. Patel	M.Com, B.Ed, Mlib, MPhil, Ph.D, NET, SLET	Ass. Prof.	Lib. Management	03+07=10	-

12. List of senior Visiting Fellows, adjunct faculty, emeritus professors -

13. Percentage of classes taken by temporary faculty – programme-wise information

UG : 70%

PG : 70%

14. Programme-wise Student Teacher Ratio

UG : 20:1

PG : 16:1

15. Number of academic support staff (technical) and administrative staff: sanctioned, filled and actual - **01 Peon**

16. Research thrust areas as recognized by major funding agencies -

17. Number of faculty with ongoing projects from a) national b) international funding agencies and c) Total grants received. Give the names of the funding agencies, project title and grants received project-wise. -

18. Inter-institutional collaborative projects and associated grants received -

a) National collaboration

b) International collaboration

19. Departmental projects funded by DST-FIST; UGC-SAP/CAS, DPE; DBT, ICSSR, AICTE, etc.; total grants received. -

20. Research facility / centre with -

- state recognition
- national recognition
- international recognition

21. Special research laboratories sponsored by / created by industry or corporate bodies -
22. Publications: -
- * Number of papers published in peer reviewed journals (national / international)
 - * Monographs
 - * Chapters in Books * Edited Books
 - * Books with ISBN with details of publishers
 - * Number listed in International Database (For *e.g.* Web of Science, Scopus, Humanities International Complete, Dare Database - International Social Sciences Directory, EBSCO host, etc.)
 - * Citation Index – range / average
 - * SNIP
 - * SJR
 - * Impact Factor – range / average
 - * h-index
23. Details of patents and income generated -
24. Areas of consultancy and income generated -
25. Faculty selected nationally / internationally to visit other laboratories / institutions / industries in India and abroad -
26. Faculty serving in - **1. Numbers of Adhec Board Of Lib. Science**
- a) National committees b) International committees c) Editorial Boards d) any other (please specify)
27. Faculty recharging strategies (UGC, ASC, Refresher / orientation programs, workshops, training programs and similar programs). -
28. Student projects -
- percentage of students who have done in-house projects including inter-departmental projects
 - percentage of students doing projects in collaboration with other universities / industry / institute
29. Awards / recognitions received at the national and international level by -
- Faculty
 - Doctoral / post doctoral fellows

- Students

30. Seminars/ Conferences/Workshops organized and the source of funding (national / international) with details of outstanding participants, if any. -

31. Code of ethics for research followed by the departments -

32. Student profile programme-wise:

Name of the Programme (refer to question no. 4)	Applications received		Selected				Pass percentage	
			Male		Female		Male	Female
2009 – 10 UG BLIB PG MLIB	50	42	30	11	20	19	100	100
2010-11 UG PG	53	58	24	15	18	35	100	100
2011 – 2012 UG PG	40	49	28	16	12	33	100	100
2012-12 UG PG	39	24	05	12	10	12	100	100

33. Diversity of students

Name of the Programme (refer to question no. 4)	% of students from the same university	% of students from other universities within the State	% of students from universities outside the State	% of students from other countries
2009 – 10 UG BLIB PG MLIB	97 95	03 05	-	-
2010-11 BLIB MLIB	100 95	- 05	-	-
2011-12 BLIB MLIB	100 96	- 04	-	-
2012-13 BLIB, MLIB	100 - 95	- , 05	-	-

34. How many students have cleared Civil Services and Defense Services examinations, NET, SET, GATE and other competitive examinations? Give details category-wise.

35. Student progression

Student progression	Percentage against enrolled
UG to PG	100%
PG to M.Phil.	-

PG to Ph.D.	-
Ph.D. to Post-Doctoral	-
Employed <input type="checkbox"/> Campus selection <input type="checkbox"/> Other than campus recruitment	-
Entrepreneurs	-

36. Diversity of staff

Percentage of faculty who are	
graduates of the same university	
from other universities within the State	
from universities from other States	100%
from universities outside the country	

37. Number of faculty who were awarded M.Phil., Ph.D., D.Sc. and D.Litt. during the assessment period -

38. Present details of departmental infrastructural facilities with regard to

- a) Library -
- b) Internet facilities for staff and students **Yes**
- c) Total number of class rooms **03**
- d) Class rooms with ICT facility **01**
- e) Students' laboratories -
- f) Research laboratories -

39. List of doctoral, post-doctoral students and Research Associates -

- a) from the host institution/university NIL
- b) from other institutions/universities NIL

40. Number of post graduate students getting financial assistance from the university. -

41. Was any need assessment exercise undertaken before the development of new programme(s)? If so, highlight the methodology. -

42. Does the department obtain feedback from

- a. faculty on curriculum as well as teaching-learning-evaluation? If yes, how does the department utilize the feedback?
 - b. students on staff, curriculum and teaching-learning-evaluation and how does the department utilize the feedback?
 - c. alumni and employers on the programmes offered and how does the department utilize the feedback?
43. List the distinguished alumni of the department (maximum 10) -
 44. Give details of student enrichment programmes (special lectures / workshops / seminar) involving external experts. -
 45. List the teaching methods adopted by the faculty for different programmes. Seminar, Group Discuss Lecture.
 46. How does the department ensure that programme objectives are constantly met and learning outcomes are monitored?
 47. Highlight the participation of students and faculty in extension activities. Youth Festival, National Seminar Participation, Quiz Compaction.
 48. Give details of “beyond syllabus scholarly activities” of the department. -
 49. State whether the programme/ department is accredited/ graded by other agencies? If yes, give details. -
 50. Briefly highlight the contributions of the department in generating new knowledge, basic or applied.
 51. Detail five major Strengths, Weaknesses, Opportunities and Challenges (SWOC) of the department.
 1. Faculty Strengths is Weak Point
 2. IT Faculty is less
 52. Future plans of the department.
 1. To Start the M. Phil Programme.

Evaluative Report of the Department of Pharmaceutical Sciences

1. Name of the Department : Department of Pharmaceutical Sciences
2. Year of establishment : 2011
3. Is the Department part of a School/Faculty of the university : Faculty of the university
4. Names of programmes offered (UG, PG, M.Phil., Ph.D., Integrated Masters; Integrated Ph.D., D.Sc., D.Litt., etc.) : PG, Ph.D.
5. Interdisciplinary programmes and departments involved: Nil
6. Courses in collaboration with other universities, industries, foreign institutions, etc. NA
7. Details of programmer discontinued, if any, with reasons NA
8. Examination System: Annual/Semester/Trimester/Choice Based Credit System
Choice Based Credit System
9. Participation of the department in the courses offered by other departments
Department of Biotechnology.
10. Number of teaching posts sanctioned, filled and actual (Professors/Associate Professors/Asst. Professors/others)

	Sanctioned	Filled	Actual (including CAS & MPS)
Professor	01	----	----
Associate Professors	01	----	----
Asst. Professors	02	03	03
Others	----	----	----

11. Faculty profile with name, qualification, designation, area of specialization, experience and research under guidance

Name	Qualification	Designation	Specialization	No. of Years of Experience	No. of Ph.D./M.Phil. students guided for the last 4 years

Name	Qualification	Designation	Specialization	No. of Years of Experience	No. of Ph.D./M.Phil. students guided for the last 4 years
Dr. Dhara B. Patel	M. Pharm, Ph.D.	Assistant Professor	Pharmaceutics	7.5	Nil
Dr. Shirish R. patel	M. Pharm, Ph.D.	Assistant Professor	Quality Assurance	7.5	Nil
Ms. Nilam K. Patel	M. Pharm,	Assistant Professor	Quality Assurance	4.5	Nil

12. List of senior Visiting Fellows, adjunct faculty, emeritus professors

- a. Dr. M. M. Patel, Principal, Shankersinh Bapu Institute of Pharmacy, Gandhinagar.
- b. Dr. C. N. Patel, Principal, Shree Sarvajanic Pharmacy College, Mehsana.
- c. Dr. J. K. Patel, Principal, Nootan Pharmacy College, Visnagar.
- d. Dr. Paresh Purohit, Professor, Department of Pharmacy, Rajkot.

13. Percentage of classes taken by temporary faculty – programme-wise information
less than 30%

14. Programme-wise Student Teacher Ratio

One teacher per twelve Students

15. Number of academic support staff (technical) and administrative staff: sanctioned, filled and actual

	Sanctioned	Filled	Actual (including CAS & MPS)
Laboratory Assistant	02	02	01
Jr. Clerk	01	01	01
Peon	02	02	02
Store Keeper	01	01	01

16. Research thrust areas as recognized by major funding agencies

- a. Formulation and development of novel drug delivery systems
- b. Analytical method development and validation
- c. Development of nanosized drug delivery systems
- d. Extraction of herbal plants and determination of biological activities of herbal extracts
- e. Herbal drug formulations and their evaluation

17. Number of faculty with ongoing projects from a) national b) international funding agencies and c) Total grants received. Give the names of the funding agencies, project title and grants received project-wise.

a) **National: Start-up-grants have been sanctioned by UGC to two faculties.**

Name of Faculty	Funding Agency	Title of Project	Grant Received
Dr. Dhara B. Patel	UGC	Development and evaluation of a novel topical treatment for acne with dual agent loaded nanoliposomes.	Rs. 6,00,000/-
Dr. Shirish R. Patel	UGC	Extraction, screening and designing nano novel particulate herbal formulation of wattakaka volubilis for antidiabetic and hepatoprotective activity	Rs. 6,00,000/-

b) **International: Nil**

c) **Total Grant received: Rs. 12,00,000/-**

18. Inter-institutional collaborative projects and associated grants received

a) National collaboration b) International collaboration

NIL

19. Departmental projects funded by DST-FIST; UGC-SAP/CAS, DPE; DBT, ICSSR, AICTE, etc.; total grants received.

Two projects funded by UGC and Total Grant received: Rs. 12,00,000/-

20. Research facility / centre with

- state recognition: Nil
- national recognition: Nil
- international recognition **Nil**

21. Special research laboratories sponsored by / created by industry or corporate bodies

Nil

22. Publications:

* Number of papers published in peer reviewed journals (national / international): **Total 36 papers**

* Name of Faculty: Dr. Dhara Patel

Sr No	Title of Paper	Journal Name	ISSN No	Volume No (Issue)	Year of Publication	National/International Peer reviewed journal
1	Liposomal drug delivery of metronidazole for the local treatment of vaginitis.	International journal of pharmaceutical science and nanotechnology	0974 - 3278	2(1)	2009	International
2	Natural excipients in controlled drug delivery systems	Journal of Pharmacy Research	1358 - 1362	2(5)	2009	International
3	Formulation and development of mucoadhesive tablet of Diltiazem hydrochloride	International Journal of Pharma and Bio Sciences	0975 - 6299	1(2)	2010	International
4	Design and development of extended release dosage form of atenolol using mucoadhesive polymers	Journal of Pharmacy Research	1358 - 1362	3(6)	2010	International
5	Temperature and pH triggered insitu hydrogel of doxycycline for the treatment of chlamydial conjunctivitis	International Journal for Pharmaceutical Research Scholars	2277 - 7873	1(2)	2012	International
6	Derivative spectrophotometric method for simultaneous determination of Granisetron and Pantoprazole in synthetic mixture.	International journal for Pharmaceutical Research Scholars	2277 - 7873	1(2)	2012	International
7	Development and validation of a stability-indicating RP-HPTLC	International journal for Pharmaceutical Research	2277 - 7873	1(2)	2012	International

	method for analysis of antiasthmatic drugs	Scholars				
8	Design and development of transdermal therapeutic system of carvedilol using combination of Natural and synthetic polymers	International Journal for Pharmaceutical Research Scholars	2277 - 7873	1(2)	2012	International
9	Formulation and evaluation of loratidine orally disintegrating tablet by different superdisintegrant and camphor as subliming agent	Current Pharma Research	2230 - 7842	3(2)	2013	National
10	Solubility enhancement of phenytoin by solid dispersion and it's Comparison with inclusion complexation	International journal of Pharmaceutical Research and Bio-Science	2277 - 8713	2(2)	2013	International
11	Formulation development and evaluation of Ramipril sublingual tablet	International journal of Pharmaceutical Research and Bio-Science	2277 - 8713	2(2)	2013	International
12	Formulation of bilayer tablets containing antihypertensive drugs	Inventi Rapid: Pharm Tech	0976 - 3783	2013(3)	2013	National
13	Effect of combination of hydrophilic polymer and natural gum on extended release	Inventi Impact NDDS	0976 - 3791	2013(4)	2013	National

	behavior of water soluble drug using factorial design					
14	Comparative evaluation of different carriers to enhance solubility and dissolution of poor water soluble drug	International Journal of Pharma and Bio Sciences	0975 - 6299	5(4)	2014	International

* Name of Faculty: Dr. Shirish Patel

Sr No	Title of Paper	Journal Name	ISSN No	Volume No (Issue)	Year of Publication	National/International Peer reviewed journal
1	Development and validation of analytical method for the determination of Rabeprazole and Ondansetron in pharmaceutical dosage form by reversed-phase HPLC	International Journal of Chemtech Research	0974-4304	2(3)	2010	International
2	Development and validation of first derivative spectroscopy method for simultaneous determination of Ondansetron and Metoclopramide in combined dosage form.	International Journal of Pharmacy and Pharmaceutical Sciences	0975-1491	3(4)	2011	International
3	Dissolution enhancement of Aceclofenac by solid dispersion	Inventi Rapid: Pharmaceutical Technology	0976-3783	2(1)	2011	National

	technique using –cyclodextrin and Crosscarmellose					
4	Validated spectroscopic method for simultaneous determination of Ondansetron and Rabeprazole in combined dosage form.	Inventi Rapid: Pharmaceutical Analysis and Quality Assurance	0976-3783	2(1)	2011	National
5	HPLC method development and validation for simultaneous estimation of Montelukast sodium and Levocetirizine dihydrochloride in pharmaceutical dosage forms.	International Journal of Pharmacy and Pharmaceutical Sciences	0975-1491	4(2)	2012	International
6	Derivative spectrophotometric method for simultaneous determination of Granisetron and Pantoprazole in synthetic mixture.	International journal for Pharmaceutical Research Scholars	2277-7873	1(2)	2012	International
7	Development and validation of a stability-indicating RP-HPTLC method for	International journal for Pharmaceutical Research Scholars	2277-7873	1(2)	2012	International

	analysis of antiasthmatic drugs					
8	Temperature and pH triggered insitu hydrogel of Doxycycline for the treatment of Chlamydial conjunctivitis.	International journal for Pharmaceutical Research Scholars	2277-7873	1(2)	2012	International
9	Derivative spectrophotometric method for simultaneous determination of Ondansetron and Rabepazole in combined dosage form.	Asian Journal of Pharmaceutical and Clinical Research	0974-2441	5(2)	2012	National
10	Development & Validation of first order derivative Spectro Photometric method for Simultaneous estimation of Fluticasone Propionate & Azelastine Hydrochloride in Nasal Spray preparation	Inventi Impact : Pharm Analysis & Quality Assurance	0976-3791	3	2013	National
11	Simultaneous Determination of Ketorolac Tromethamine & Olopatadine Hydrochloride by Ultraviolet	Inventi Rapid: Pharm Analysis & Quality Assurance	0976-3783	3	2013	National

	Spectro Photometry (Simultaneous Equation Method)					
12	Simultaneous Determination of Montelukast Sodium & Olopatadine Hydrochloride by Ultraviolet Spectrophotom etry (Dual Wavelength Method)	Inventi Rapid: Pharm Analysis & Quality Assurance	0976- 3783	3	2013	National
13	Development of UV Spectrophotom etric Method for Area Under Curve of Lignocaine & Propofol in Pharmaceutical Combined Dosage form (Simultaneous Equation Method)	Inventi Rapid: Pharm Analysis & Quality Assurance	0976- 3783	3	2013	National
14	Derivative spectrophotom etric method for simultaneous determination of Ondansetron and omeprazole in combined dosage form	International Journal of Chemtech Applications	2319- 7099	3(2)	2014	International

* Name of Faculty: Nilam Patel

Sr No	Title of Paper	Journal Name	ISSN No	Volume No (Issue)	Year of Publicati on	National/Inter national Peer reviewed
----------	----------------	--------------	------------	-------------------------	----------------------------	---

						journal
1	Spectrophotometric Determination of Montelukast Sodium and Levocetirizine Dihydrochloride in Tablet Dosage Form by AUC Curve Method	Der Pharma Chemica	0975-413X	3(5)	2011	National
2	Spectrofluorimetric Determination of the H1 blocker Drug Levocetirizine dihydrochloride Based on its Oxidation with Cerium (IV) In Bulk and Pharmaceutical formulations	International Journal of Pharm Tech Research	0974-4304	3(4)	2011	International
3	Derivative spectrophotometric method for simultaneous determination of Granisetron and Pantoprazole in synthetic mixture	International journal for Pharmaceutical Research Scholars	2277-7873	1(2)	2012	International
4	Development and validation of a stability-indicating HPTLC method for analysis of antiasthmatic drugs	International journal for Pharmaceutical Research Scholars	2277-7873	1(2)	2012	International
5	Temperature and pH triggered insitu hydrogel of doxycycline for the treatment of chlamydial conjunctivitis	International Journal for Pharmaceutical Research Scholars	2277-7873	1(2)	2012	International

6	HPLC Method Development and Validation for Simultaneous estimation of Montelukast sodium and Levocetirizine.	International Journal of Pharmacy and Pharmaceutical Sciences	0975-1491	4(2)	2012	International
7	Simultaneous determination of Azelnidipine and Olmesartan medoxomil by first Derivative spectrophotometric method	Der Pharmacia letter	0975-5071	4(4)	2012	National
8	Simultaneous UV spectrophotometric methods for estimation of Cilnidipine and Telmisartan in tablet dosage form	Inventi Rapid: Pharm Analysis & Quality Assurance		11/06/2012	2012	National
9	Analytical methodologies for determination of Telmisartan: An Overview	International Journal of Pharmacy and Pharmaceutical Sciences	0975-1491	5(1)	2013	National
10	Development & Validation of first order derivative Spectro Photometric method for Simultaneous estimation of Fluticasone Propionate & Azelastine Hydrochloride in Nasal Spray preparation	Inventi Impact : Pharm Analysis & Quality Assurance	0976-3791	3	2013	National
11	Simultaneous Determination of	Inventi Rapid: Pharm	0976-3783	3	2013	National

	Ketorolac Tromethamine & Olopatadine Hydrochloride by Ultraviolet Spectro Photometry (Simultaneous Equation Method)	Analysis & Quality Assurance				
12	Simultaneous Determination of Montelukast Sodium & Olopatadine Hydrochloride by Ultraviolet Spectrophotometr y (Dual Wavelength Method)	Inventi Rapid: Pharm Analysis & Quality Assurance	0976- 3783	3	2013	National
13	Development & Validation of ratio Derivative SpectroPhotometr ic Method for Simultaneous Estimation of Pantoprazole & Levosulpiride in Combind Dosage	Inventi Rapid: Pharm Analysis & Quality Assurance	0976- 3783	3	2013	National
14	Cleaning Validation & Development of Ranitidine by Using Total organic Carbon	Inventi Rapid: Pharm Analysis & Quality Assurance	0976- 3783	3	2013	National
15	Development of UV Spectrophotometr ic Method for Area Under Curve of Lignocaine & Propofol in Pharmaceutical	Inventi Rapid: Pharm Analysis & Quality Assurance	0976- 3783	3	2013	National

	Combined Dosage form (Simultaneous Equation Method)					
16	Development & Validation of Dual Wavelength Method for Simultaneous Estimation of Esomeprazole & Levosulpiride in Combined Capule Dosage Form.	International Journal of Pharmaceutical Research & Bio Science	2277-8713	2(2)	2013	International
17	Development and Validation of IR Spectrophotometric Method for estimation of Azelastine Hydrochloride in Nasal Spray Preparations	Pharmatutor		2013	2013	National
18	Validated Stability-Indicating RP-HPLC Method for the Simultaneous Determination of Azelnidipine and Olmesartan in Their Combined Dosage Form	Scientia Pharmaceutica	-	82	2014	International
19	Stability-Indicating RP-HPLC Method for the Determination of Ambrisentan and Tadalafil in Pharmaceutical Dosage Form	Scientia Pharmaceutica	-	82	2014	

* Monographs: Nil

- * Chapters in Books: Nil
 - * Edited Books: 05 books
 - * Books with ISBN with details of publishers: 05 books
 1. Title: Novel Insulin drug delivery
ISBN No.: 978-3-659-48287-8
Author Name: Dr. Dhara B. Patel
Publisher: Lambert Academic Publication
 2. Title: Cleaning Validation
ISBN No.: 978-3-659-25369-0
Author Name: Dr. Shirish R. Patel
Publisher: Lambert Academic Publication
 3. Title: Quantification from Chromatographic peak
ISBN No.: 978-3-659-44813-3
Author Name: Ms. Nilam K. Patel
Publisher: Lambert Academic Publication
 4. Title: Extended release tablet of antidiabetic drug: Development optimization and evaluation.
ISBN No.: 978-3-659-44814-0
Author Name: Dr. Dhara B. Patel
Publisher: Lambert Academic Publication
 5. Title: Obesity and its remedies
ISBN No.: 978-3-659-45498-1
Author Name: Dr. Shirish R. Patel
Publisher: Lambert Academic Publication

 - * Number listed in International Database (For *e.g.* Web of Science, Scopus, Humanities International Complete, Dare Database - International Social Sciences Directory, EBSCO host, etc.)
- 35 papers**

* Name of Faculty: Dr. Dhara Patel

Sr No	Title of Paper	Journal Name	ISSN No	Volume No (Issue)	Year of Publication	National/International Peer reviewed journal
1	Liposomal drug delivery of metronidazole for the local treatment of vaginitis.	International journal of pharmaceutical science and nanotechnology	0974-3278	2(1)	2009	International
2	Natural excipients in controlled drug delivery systems	Journal of Pharmacy Research	1358-1362	2(5)	2009	International
3	Formulation and development of mucoadhesive tablet of Diltiazem hydrochloride	International Journal of Pharma and Bio Sciences	0975-6299	1(2)	2010	International
4	Design and development of extended release dosage form of atenolol using mucoadhesive polymers	Journal of Pharmacy Research	1358-1362	3(6)	2010	International
5	Temperature and pH triggered insitu hydrogel of doxycycline for the treatment of chlamydial conjunctivitis	International Journal for Pharmaceutical Research Scholars	2277-7873	1(2)	2012	International
6	Derivative spectrophotometric method for simultaneous determination of Granisetron and Pantoprazole in synthetic mixture.	International journal for Pharmaceutical Research Scholars	2277-7873	1(2)	2012	International
7	Development and validation of a stability-indicating	International journal for Pharmaceutical	2277-7873	1(2)	2012	International

	RP-HPTLC method for analysis of antiasthmatic drugs	al Research Scholars				
8	Design and development of transdermal therapeutic system of carvedilol using combination of Natural and synthetic polymers	International Journal for Pharmaceutical Research Scholars	2277-7873	1(2)	2012	International
9	Solubility enhancement of phenytoin by solid dispersion and it's Comparison with inclusion complexation	International journal of Pharmaceutical Research and Bio-Science	2277-8713	2(2)	2013	International
10	Formulation development and evaluation of Ramipril sublingual tablet	International journal of Pharmaceutical Research and Bio-Science	2277-8713	2(2)	2013	International
11	Formulation of bilayer tablets containing antihypertensive drugs	Inventi Rapid: Pharm Tech	0976-3783	2013(3)	2013	National
12	Effect of combination of hydrophilic polymer and natural gum on extended release behavior of water soluble drug using factorial design	Inventi Impact NDDS	0976-3791	2013(4)	2013	National
13	Comparative evaluation of different carriers to enhance	International Journal of Pharma and Bio Sciences	0975-6299	5(4)	2014	International

	solubility and dissolution of poor water soluble drug					
--	---	--	--	--	--	--

* Name of Faculty: Dr. Shirish Patel

Sr No	Title of Paper	Journal Name	ISSN No	Volume No (Issue)	Year of Publication	National/International Peer reviewed journal
1	Development and validation of analytical method for the determination of Rabeprazole and Ondansetron in pharmaceutical dosage form by reversed-phase HPLC	International Journal of Chemtech Research	0974-4304	2(3)	2010	International
2	Development and validation of first derivative spectroscopy method for simultaneous determination of Ondansetron and Metoclopramide in combined dosage form.	International Journal of Pharmacy and Pharmaceutical Sciences	0975-1491	3(4)	2011	International
3	Dissolution enhancement of Aceclofenac by solid dispersion technique using β -cyclodextrin and Crosscarmellose	Inventi Rapid: Pharmaceutical Technology	0976-3783	2(1)	2011	National
4	Validated spectroscopic	Inventi Rapid: Pharmaceutical	0976-3783	2(1)	2011	National

	method for simultaneous determination of Ondansetron and Rabeprazole in combined dosage form.	I Analysis and Quality Assurance				
5	HPLC method development and validation for simultaneous estimation of Montelukast sodium and Levocetirizine dihydrochloride in pharmaceutical dosage forms.	International Journal of Pharmacy and Pharmaceutical Sciences	0975-1491	4(2)	2012	International
6	Derivative spectrophotometric method for simultaneous determination of Granisetron and Pantoprazole in synthetic mixture.	International journal for Pharmaceutical Research Scholars	2277-7873	1(2)	2012	International
7	Development and validation of a stability-indicating RP-HPTLC method for analysis of antiasthmatic drugs	International journal for Pharmaceutical Research Scholars	2277-7873	1(2)	2012	International
8	Temperature and pH triggered insitu hydrogel of	International journal for Pharmaceutical Research	2277-7873	1(2)	2012	International

	Doxycycline for the treatment of Chlamydial conjunctivitis.	Scholars				
9	Derivative spectrophotometric method for simultaneous determination of Ondansetron and Rabepazole in combined dosage form.	Asian Journal of Pharmaceutical and Clinical Research	0974-2441	5(2)	2012	National
10	Development & Validation of first order derivative Spectro Photometric method for Simultaneous estimation of Fluticasone Propionate & Azelastine Hydrochloride in Nasal Spray preparation	Inventi Impact : Pharm Analysis & Quality Assurance	0976-3791	3	2013	National
11	Simultaneous Determination of Ketorolac Tromethamine & Olopatadine Hydrochloride by Ultraviolet Spectro Photometry (Simultaneous Equation Method)	Inventi Rapid: Pharm Analysis & Quality Assurance	0976-3783	3	2013	National
12	Simultaneous Determination	Inventi Rapid: Pharm	0976-3783	3	2013	National

	of Montelukast Sodium & Olopatadine Hydrochloride by Ultraviolet Spectrophotometry (Dual Wavelength Method)	Analysis & Quality Assurance				
13	Development of UV Spectrophotometric Method for Area Under Curve of Lignocaine & Propofol in Pharmaceutical Combined Dosage form (Simultaneous Equation Method)	Inventi Rapid: Pharm Analysis & Quality Assurance	0976-3783	3	2013	National
14	Derivative spectrophotometric method for simultaneous determination of Ondansetron and omeprazole in combined dosage form	International Journal of Chemtech Applications	2319-7099	3(2)	2014	International

* Name of Faculty: Nilam Patel

Sr No	Title of Paper	Journal Name	ISSN No	Volume No (Issue)	Year of Publication	National/ International Peer reviewed journal
1	Spectrophotometric Determination of Montelukast Sodium and Levocetirizine Dihydrochloride in	Der Pharma Chemica	0975-413X	3(5)	2011	National

	Tablet Dosage Form by AUC Curve Method					
2	Spectrofluorimetric Determination of the H1 blocker Drug Levocetirizine dihydrochloride Based on its Oxidation with Cerium (IV) In Bulk and Pharmaceutical formulations	International Journal of Pharm Tech Research	0974-4304	3(4)	2011	International
3	Derivative spectrophotometric method for simultaneous determination of Granisetron and Pantoprazole in synthetic mixture	International journal for Pharmaceutical Research Scholars	2277-7873	1(2)	2012	International
4	Development and validation of a stability-indicating HPTLC method for analysis of antiasthamatic drugs	International journal for Pharmaceutical Research Scholars	2277-7873	1(2)	2012	International
5	Temperature and pH triggered insitu hydrogel of doxycycline for the treatment of chlamydial conjunctivitis	International Journal for Pharmaceutical Research Scholars	2277-7873	1(2)	2012	International
6	HPLC Method Development and Validation for Simultaneous estimation of Montelukast sodium and Levocetirizine.	International Journal of Pharmacy and Pharmaceutical Sciences	0975-1491	4(2)	2012	International
7	Simultaneous determination of Azelnidipine and Olmesartan	Der Pharmacia letter	0975-5071	4(4)	2012	National

	medoxomil by first Derivative spectrophotometric method					
8	Simultaneous UV spectrophotometric methods for estimation of Cilnidipine and Telmisartan in tablet dosage form	Inventi Rapid: Pharm Analysis & Quality Assurance		11/06/2012	2012	National
9	Analytical methodologies for determination of Telmisartan: An Overview	International Journal of Pharmacy and Pharmaceutical Sciences	0975-1491	5(1)	2013	National
10	Development & Validation of first order derivative Spectro Photometric method for Simultaneous estimation of Fluticasone Propionate & Azelastine Hydrochloride in Nasal Spray preparation	Inventi Impact : Pharm Analysis & Quality Assurance	0976-3791	3	2013	National
11	Simultaneous Determination of Ketorolac Tromethamine & Olopatadine Hydrochloride by Ultraviolet Spectro Photometry (Simultaneous Equation Method)	Inventi Rapid: Pharm Analysis & Quality Assurance	0976-3783	3	2013	National
12	Simultaneous Determination of Montelukast Sodium & Olopatadine Hydrochloride by Ultraviolet	Inventi Rapid: Pharm Analysis & Quality Assurance	0976-3783	3	2013	National

	Spectrophotometry (Dual Wavelength Method)					
13	Development & Validation of ratio Derivative Spectrophotometric Method for Simultaneous Estimation of Pantoprazole & Levosulpiride in Combined Dosage	Inventi Rapid: Pharm Analysis & Quality Assurance	0976-3783	3	2013	National
14	Cleaning Validation & Development of Ranitidine by Using Total organic Carbon	Inventi Rapid: Pharm Analysis & Quality Assurance	0976-3783	3	2013	National
15	Development of UV Spectrophotometric Method for Area Under Curve of Lignocaine & Propofol in Pharmaceutical Combined Dosage form (Simultaneous Equation Method)	Inventi Rapid: Pharm Analysis & Quality Assurance	0976-3783	3	2013	National
16	Development & Validation of Dual Wavelength Method for Simultaneous Estimation of Esomeprazole & Levosulpiride in Combined Capule Dosage Form.	International Journal of Pharmaceutical Research & Bio Science	2277-8713	2(2)	2013	International
17	Development and Validation of IR Spectrophotometric Method for estimation of Azelastine Hydrochloride in Nasal Spray	Pharmatutor		2013	2013	National

	Preparations					
18	Validated Stability-Indicating RP-HPLC Method for the Simultaneous Determination of Azelnidipine and Olmesartan in Their Combined Dosage Form	Scientia Pharmaceutica	-	82	2014	International
19	Stability-Indicating RP-HPLC Method for the Determination of Ambrisentan and Tadalafil in Pharmaceutical Dosage Form	Scientia Pharmaceutica	-	82	2014	

Name of Faculty	Citation Index	SNIP	SJR	Impact Factor	h-index
Dr. Dhara B. Patel	29	0.77	0.288	5.625	3
Dr. Shirish R. Patel	20	---	1.293	—	3
Ms. Nilam K. Patel	6	---	1.58	—	2

23. Details of patents and income generated **Nil**

24. Areas of consultancy and income generated **Nil**

25. Faculty selected nationally / internationally to visit other laboratories / institutions / industries in India and abroad **Nil**

26. Faculty serving in
 a) National committees b) International committees c) Editorial Boards d) any other (please specify): Nil
27. Faculty recharging strategies (UGC, ASC, Refresher / orientation programs, workshops, training programs and similar programs). **UGC**
28. Student projects
- percentage of students who have done in-house projects including inter-departmental projects
More than 70%
 - percentage of students doing projects in collaboration with other universities / industry / institute
Less than 30 %
29. Awards / recognitions received at the national and international level by
- Faculty **NIL**
 - Doctoral / post doctoral fellows **NIL**
 - Students **NIL**
 -
30. Seminars/ Conferences/Workshops organized and the source of funding (national / international) with details of outstanding participants, if any.
01 National Seminar on "Challenges, opportunities & Innovations in Pharmaceutical Sciences" was organized on 13th Feb 2013, Funded by GUJCOST, Gandhinagar.
31. Code of ethics for research followed by the departments
 Genuine novel research work is being carried out by Faculty and Students of the department with a view to enhance availability, technological advancement and ensure safety, quality and efficacy of pharmaceutical products.
32. Student profile programme-wise:

Name of the Programme (refer to question no. 4)	Applications received	Selected		Pass percentage	
		Male	Female	Male	Female
M. Pharm (Batch 2011-13)	41	34	07	100	100
M. Pharm (Batch 2012-14)	12	09	03	100	100
M. Pharm (Batch 2013-15)	06	02	04	---	---

33. Diversity of students

Name of the Programme (refer to question no. 4)	% of students from the same university	% of students from other universities within the State	% of students from universities outside the State	% of students from other countries
M. Pharm (Batch 2011-13)	25	41	34	nil
M. Pharm (Batch 2012-14)	nil	58	42	nil
M. Pharm (Batch 2013-15)	nil	83	17	nil

34. How many students have cleared Civil Services and Defence Services examinations, NET, SET, GATE and other competitive examinations? Give details category-wise.

01

Name of student	Year of Admission	Category	Qualifying Examination	Score obtained (Max: 500)	Minimum score required for SC
Parmar Rahul M.	2014	SC	GPAT	108	100

35. Student progression

Student progression	Percentage against enrolled
UG to PG	NA
PG to M.Phil.	NA
PG to Ph.D.	NIL
Ph.D. to Post-Doctoral	NA
Employed	
• Campus selection	NIL
• Other than campus recruitment	80%
Entrepreneurs	10%

36. Diversity of staff

Percentage of faculty who are graduates	
of the same university	100%
from other universities within the State	NIL
from universities from other States	NIL
from universities outside the country	NIL

37. Number of faculty who were awarded M.Phil., Ph.D., D.Sc. and D.Litt. during the assessment period
Following two faculties were awarded Ph.D. degree
Dr. Dhara B. Patel
Dr. Shirish R. Patel
38. Present details of departmental infrastructural facilities with regard to
a) Library: **281 Books, 12 Journals, 8 Magazines & 5 News papers**
b) Internet facilities for staff and students: **Staff-4, Students- 20**
c) Total number of class rooms **02**
d) Class rooms with ICT facility **02**
e) Students' laboratories **03**
f) Research laboratories **01**
39. List of doctoral, post-doctoral students and Research Associates
a) from the host institution/university **NIL**
b) from other institutions/universities **NIL**
40. Number of post graduate students getting financial assistance from the university.
NIL
41. Was any need assessment exercise undertaken before the development of new programme(s)? If so, highlight the methodology.
No
42. Does the department obtain feedback from
a. faculty on curriculum as well as teaching-learning-evaluation? If yes, how does the department utilize the feedback?
Yes
Department utilize the faculty feedback to improvise the teaching-learning skills, research skills and curriculum.
b. students on staff, curriculum and teaching-learning-evaluation and how does the department utilize the feedback?
Yes

Department utilize the student feedback to improvise the teaching-learning skills, research skills and curriculum.

- c. alumni and employers on the programmes offered and how does the department utilize the feedback?

No

43. List the distinguished alumni of the department (maximum 10): Nil
44. Give details of student enrichment programmes (special lectures / workshops / seminar) involving external experts.
- 1) National seminar on "Challenges, opportunities & Innovations in Pharmaceutical Sciences" was organized on 13th Feb 2013.
 - 2) Special lectures on "Drug regulatory affairs" and "Research Methodology" delivered by Dr. Purohit and Dr. P.D. Bharadia respectively.
 - 3) Industrial visit.
45. List the teaching methods adopted by the faculty for different programmes.
- blackboard teaching
PPT presentations
Practicals
Seminars
Assignments
46. How does the department ensure that programme objectives are constantly met and learning outcomes are monitored?
Through student feedbacks, evaluation by class tests, interactions with industry people, research paper publication and presentation in seminars etc.
47. Highlight the participation of students and faculty in extension activities.
Nil
48. Give details of "beyond syllabus scholarly activities" of the department.
Industrial visits and research paper/poster presentation in National and International conferences/seminars.
49. State whether the programme/ department is accredited/ graded by other agencies?
If yes, give details.
No
50. Briefly highlight the contributions of the department in generating new knowledge, basic or applied.
Faculty members and students of final semester of M. Pharm of Department are doing projects on new analytical method developments and preparation and evaluation of new drug delivery systems for new molecules and herbal drug and their combinations.

51. Detail five major Strengths, Weaknesses, Opportunities and Challenges (SWOC) of the department.

Major strengths:

- Availability of excellent research platform
- Availability of better learning resources
- Better industry-academia cooperatiohn
- Encouraging research tendency in students through seminar, workshops, etc
- Central library facility for referencing

Weaknesses:

- Funding constraints for improvement of research infrastructure
- Lack of International research journals in library

Opportunities:

- Research Publications
- Research presentations
- Patents application
- Research project funding
- Industry-Academia linkages
- Exchange of knowledge between students and eminent personalities of field through seminar, conferences, workshops, etc
- Consultancy projects

Challenges:

- Innovations in learning methodology
- Improvement in resource facility
- Improvement in research infrastructure
- Lack of Awareness among students about the role of pharmacy profession
- Direct involvement of Pharmacy profession in Social welfare

52. Future plans of the department.

In future Department will do

- Inter-institutional and Industry-Institutional collaborative projects on new analytical method developments for herbal drug combinations and preparation of new herbal formulations and their evaluation.
- Patents on new formulation designs.
- International conferences on global challenges of pharmaceutical Sciences.

Evaluative Report of the Department of Physics & Electronics

1. Name of the Department : Department of Physics & Electronics
2. Year of establishment : 2003
3. Is the Department of the university- yes
4. Names of programmes offered (PG) M.Sc.(Physics) and M.Sc.(Electronics)
5. Interdisciplinary programmes and departments involved –
6. Courses in collaboration with other universities, industries, foreign institutions, etc.
–
7. Details of programmer discontinued, if any, with reasons –
8. Examination System: Semester with CBCS --
9. Participation of the department in the courses offered by other departments –
10. Number of teaching posts sanctioned, filled and actual (Professors/Associate Professors/Asst. Professors/others)

	Sanctioned	Filled	Actual (including CAS & MPS)
Professor	—	—	—
Associate Professors	—	—	—
Asst. Professors	—	01	—
Others	—	—	—

11. Faculty profile with name, qualification, designation, area of specialization, experience and research under guidance

Name	Qualification	Designation	Specialization	No. of Years of Experience	No. of Ph.D./M.Phil. students guided for the last 4 years
Dr. D.G.Vyas	M.Sc., Ph.D., NET	Assi.Professor & Head	Microprocessor &	14 Yers	—

Name	Qualification	Designation	Specialization	No. of Years of Experience	No. of Ph.D./M.Phil. students guided for the last 4 years
			Microcontroller		

12. List of senior Visiting Fellows, adjunct faculty, emeritus professors
List of all visiting Teachers is attached.
13. Percentage of classes taken by temporary faculty – programme-wise information
M.Sc.(Physics)-75% to 85% (Approximately)
M.Sc.(Electronics)-75% to 85% (Approximately)
14. Programme-wise Student Teacher Ratio
1-Teacher : 94-Students
15. Number of academic support staff (technical) and administrative staff: sanctioned, filled and actual
1-Lab Assistant
1-Clark
1-Peon
16. Research thrust areas as recognized by major funding agencies
Major thrust areas of research-Microcontroller Hardware and software, Computer Software, Optical communication(VLC)
The department has not yet funded by any agency.
17. Number of faculty with ongoing projects from a) national b) international funding agencies and c) Total grants received. Give the names of the funding agencies, project title and grants received project-wise. –
18. Inter-institutional collaborative projects and associated grants received
a) National collaboration b) International collaboration –
19. Departmental projects funded by DST-FIST; UGC-SAP/CAS, DPE; DBT, ICSSR, AICTE, etc.; total grants received. --
20. Research facility / centre with
 - state recognition
 - national recognition
 - international recognition
21. Special research laboratories sponsored by / created by industry or corporate bodies

--
22.Publications:

Number of papers published in peer reviewed journals (national / international)
13 Publication(last five years)

Publication in National/International Journals

Year 2009-10

1. (Sole author) Development of software to change the radix of a real number, LE , Journal of Laboratory Experiments, Vol.-9, No.-4, Dec.-2009 Page No. 280 to 284.(ISSN 0972-6055)
2. The experiment to find the CBW for IR light communication, Bulletin of the Indian Association of Physics Teachers (IAPT), Volume-1, No.-09, September-2009 Page No. 234 to 238.[Authors: D.G.VYAS & K.R.PATEL](ISSN 2277-8950)

Year 2010-11

3. (Sole author) Design and construction of simple ADC experiment using PIC 16F72, Journal of Laboratory Experiments, Vol.-11, No.-4, March-2011 Page No. 15 to 20. (ISSN 0972-6055)
4. (Sole author) Developing experiments for deeper understanding of PIC 16F72 in timing insensitive mode, Journal of SCI-TECH Research, Vol.-2, Issue-1,Jan.-June-2011, Page no. 52 to 54.(ISSN 0974 – 9780)

Year 2011-12

5. (Sole Author) An Experiment to establish Unidirectional communication link using LASER light, Journal of Laboratory Experiments, Vol.-12, No.-1, March-2012 Page No. 63 to 69.(ISSN 0972-6055)
6. (Sole Author) Microcontroller based Electronic Calculator, Electronics For You, Vol.-43, No.-6, August 2011 Page No. 115 to 118.(ISSN 0013-516X)

Year 2012-13

7. (Sole Author) Design and Construction of Power supply for Embedded System, Asian Journal of Science and Applied Technology, Vol.-1, No.-2, July-December 2012 Page no. 24 to 27, (ISSN 2249-0698)
8. (Sole Author) Real –Time Clock, Electronics For You, Vol.-44, No.-12, December- 2012 Page No. 102 to 106.(ISSN 0013-516X)

9. (Sole Author) Study of fiberless simplex visual light communication, Journal of Laboratory Experiments, Vol.-12, No.-2, June-2012 Page No. 163 to 168.(ISSN 0972-6055)

10. (Sole Author) Design and development of free downloadable software to find weight on different celestial bodies, National level seminar on Enhancing Teaching/Learning through Multimedia & Web 2.0 Technology”, seminar manual of Abstracts and Papers dated 24th March, 2013 at Science city, Ahmedabad. Page no. 28 to 34.

Year 2013-14

11. (Sole Author) Design and development of system to send multiple SMS using GM-862 GPS based module, Journal of the Instrument society of India, Vol.-44, No.-1, March-2014 Page no. 71 to 72.(ISSN 0970-9983)

12. (Sole Author) Stop clock with battery backup, Electronics For You, Vol.-45, No.-08 August-2013 Page no. 104 to 106.(ISSN 0013-516X)

13. (Sole Author) Design and construction of an embedded system for accurate pulse width measurement using microcontroller AT89S52, Journal of Laboratory Experiments, Vol.-14, No.-1, March-2014 Page No. 1 to 6.(ISSN 0972-6055)

- * Monographs Nil
- * Chapters in Books Nil
- * Edited Books Nil
- * Books with ISBN with details of publishers Nil
- * Number listed in International Database (For *e.g.* Web of Science, Scopus, Humanities International Complete, Dare Database - International Social Sciences Directory, EBSCO host, etc.) Nil
- * Citation Index – range / average Nil
- * SNIP Nil
- * SJR Nil
- * Impact Factor – range / average Nil
- * h-index Nil

23. Details of patents and income generated --

24. Areas of consultancy and income generated --

25. Faculty selected nationally / internationally to visit other laboratories / institutions / industries in India and abroad –

26. Faculty serving in

National committees b) International committees c) Editorial Boards d) any other (please specify) --

27. Faculty recharging strategies (UGC, ASC, Refresher / orientation programs, workshops, training programs and similar programs). –

28. Student projects

- percentage of students who have done in-house projects including inter-departmental projects 100%
- percentage of students doing projects in collaboration with other universities / industry / institute –
-

29. Awards / recognitions received at the national and international level by

- Faculty
- Doctoral / post doctoral fellows
- Students

30. Seminars/ Conferences/Workshops organized and the source of funding (national / international) with details of outstanding participants, if any.

- (1) H.N.G.U. Funded 29/09/2013 Workshop on Astronomy & Astrophysics
- (2) (Punabha lok vigyan kendra, patan)GUJCOST Funded 28/10/2013 & 29/10/2013 Workshop on Electronics Calculator

31. Code of ethics for research followed by the departments

As per university norms

32. Student profile programme-wise:

Name of the Programme (refer to question no. 4)	Applications received	Selected		Pass percentage	
		Male	Female	Male	Female
_____	_____	_____	_____	_____	_____
_____	_____	_____	_____	_____	_____

33. Diversity of students

Name of the Programme (refer to question no. 4)	% of students from the same university	% of students from other universities within the State	% of students from universities outside the State	% of students from other countries
_____	95%	5%	_____	_____
_____	_____	_____	_____	_____
_____	_____	_____	_____	_____
_____	_____	_____	_____	_____

34. How many students have cleared Civil Services and Defence Services examinations, NET, SET, GATE and other competitive examinations? Give details category-wise.

35. Student progression

Student progression	Percentage against enrolled
UG to PG	Year:Physics+Electronics 2009-10 : 07+07 2010-11: 05+00 2011-12: 29+19 2012-13: 30+20 2013-14: 34+20 No idea about enrollment in T.Y.B.Sc.
PG to M.Phil.	_____
PG to Ph.D.	_____
Ph.D. to Post-Doctoral	_____
Employed	
<ul style="list-style-type: none"> • Campus selection • Other than campus recruitment 	
Entrepreneurs	_____

36. Diversity of staff

Percentage of faculty who are graduates	
of the same university	0%
from other universities within the State	100%
from universities from other States	0%
from universities outside the country	0%

37. Number of faculty who were awarded M.Phil., Ph.D., D.Sc. and D.Litt. during the assessment period

38. Present details of departmental infrastructural facilities with regard to

a) Library	0
b) Internet facilities for staff and students	one PC with HOD
c) Total number of class rooms	2
d) Class rooms with ICT facility	-
e) Students' laboratories	1
f) Research laboratories	0

39. List of doctoral, post-doctoral students and Research Associates
- a) from the host institution/university
 - b) from other institutions/universities
40. Number of post graduate students getting financial assistance from the university.
3- Students
41. Was any need assessment exercise undertaken before the development of new programme(s)? If so, highlight the methodology.
42. Does the department obtain feedback from
- a. faculty on curriculum as well as teaching-learning-evaluation? If yes, how does the department utilize the feedback?
The curriculum is designed by Board of Study and departmental faculties are often discussing the important issues with chairman of BOS. This process is verbal.
 - b. students on staff, curriculum and teaching-learning-evaluation and how does the department utilize the feedback?
All students are often discussing their issues with Head and it will be solved as early as possible. This process is verbal.
 - c. alumni and employers on the programmes offered and how does the department utilize the feedback?
Many alumni students are often giving their views and ideas for the betterment of education and the HOD takes care about the same. This process is verbal.
43. List the distinguished alumni of the department (maximum 10)
- 1) Patel Kishor
 - 2) Patel Ankitaben babulal
 - 3) Patel Bharat
 - 4) Modh Falgun
 - 5) Chaudhari Haresh
 - 6) Patel Chintu
 - 7) Brambhatt Sonam
 - 8) Dhaval Joshi
 - 9) Prajapati Falguni
 - 10) Jha Vijay
44. Give details of student enrichment programmes (special lectures / workshops / seminar) involving external experts.
- Popular lectures
- (1) 19/09/2011 by Harshad Chirutker
 - (2) 23/02/2012 by Dr. Rekhaben Patel & Dr. R.J.Pathak

(3) 10/10/2012 by Dr. R.J.Pathak

45. List the teaching methods adopted by the faculty for different programmes.

46. How does the department ensure that programme objectives are constantly met and learning outcomes are monitored?

47. Highlight the participation of students and faculty in extension activities.

M.Sc. (Electronics) Student in 2009

48. Give details of “beyond syllabus scholarly activities” of the department.

M.Sc.(Physics) students are doing minor project in each semester.

M.Sc.(Physics & Electronics) students are giving seminars in each semester.

49. State whether the programme/ department is accredited/ graded by other agencies?

If yes, give details. No

50. Briefly highlight the contributions of the department in generating new knowledge, basic or applied. No

51. Detail five major Strengths, Weaknesses, Opportunities and Challenges (SWOC) of the department.

Strengths:

1. The Laboratory Facility available in the department is the major strength of the department.
2. Students are guided to perform various minor and major projects.
3. All students are giving at least one seminar in each semester.

Weaknesses:

- 1) The number of full time faculty is very less.
- 2) The department does not have separate computer laboratory.
- 3) The computers available in laboratory is old and not having internet facility.

Opportunities:

- 1) The department can be converted into fully grant in aid in future and it can develop a lot.
- 2) The students passing from this department can get jobs in teaching, industry, Public sectors and research.

Challenges:

- 1) The department is self finance and it is difficult to do research on self finance basis.
- 2) The income and expenditure of the department is difficult to manage.

52. Future plans of the department.

To Convert Department in to Fuly Grant-In-Aid.

Evaluative Report of Department of Physical Education

1. Name of the Department : Department of Physical Education
2. Year of establishment : 2002
3. Is the Department part of a School/Faculty of the university?
Faculty of the university
4. Names of programmes offered (UG, PG, M.Phil., Ph.D., Integrated Masters; Integrated Ph.D., D.Sc., D.Litt., etc.)
UG, PG, M.Phil
5. Interdisciplinary programmes and departments involved - N.A.
6. Courses in collaboration with other universities, industries, foreign institutions, etc. - N.A.
7. Details of programmes discontinued, if any, with reasons - N.A.
8. Examination System: Annual/Semester/Trimester/Choice Based Credit System
Choice Based Credit System
9. Participation of the department in the courses offered by other departments
M.sc C.A. & I.T. sem-VI
Yoga & Health
10. Number of teaching posts sanctioned, filled and actual
(Professors/Associate Professors/Asst. Professors/others)

	Sanctioned	Filled	Actual (including CAS & MPS)
Professor			
Associate Professors			
Asst. Professors	03	03	
Others			

11. Faculty profile with name, qualification, designation, area of specialization, experience and research under guidance

Name	Qualification	Designation	Specialization	No. of Years of Experience	No. of Ph.D./M.Phil. students guided for the last 4 years
Dr. V.R.	B.P.E., M.P.E	I/C HOD	Phy.Edu. Sub	11 yrs.	M.Phil-15

Name	Qualification	Designation	Specialization	No. of Years of Experience	No. of Ph.D./M.Phil. students guided for the last 4 years
Chaudhari	Ph.D.				
Dr. V.G. Chaudhari	B.P.E., M.P.E Ph.D.	Ass. Prof.	Phy.Edu. Sub	11 yrs.	M.Phil-15
Dr. V.H. Upadhyay	B.P.E., M.P.E Ph.D. GSLET	Ass. Prof.	Phy.Edu. Sub	09 yrs.	M.Phil-15 3- Ph.D. Other Uni.

12. List of senior Visiting Fellows, adjunct faculty, emeritus professors
N.A.
13. Percentage of classes taken by temporary faculty – programme-wise information
N.A.
14. Programme-wise Student Teacher Ratio
10:01
15. Number of academic support staff (technical) and administrative staff: sanctioned, filled and actual
(i) Clerk -1, (ii) Peon-1, (iii) Ground Supervisor-1
16. Research thrust areas as recognized by major funding agencies
N.A.
17. Number of faculty with ongoing projects from a) national b) international funding agencies and c) Total grants received. Give the names of the funding agencies, project title and grants received project-wise.
Nil
18. Inter-institutional collaborative projects and associated grants received -
Nil
a) National collaboration
b) International collaboration
19. Departmental projects funded by DST-FIST; UGC-SAP/CAS, DPE; DBT, ICSSR, AICTE, etc.; total grants received.
N.A.
20. Research facility / centre with - **N.A.**
- state recognition
 - national recognition
 - international recognition

21. Special research laboratories sponsored by / created by industry or corporate bodies - N.A.
22. Publications:
- * Number of papers published in peer reviewed journals (national / international)
 1. Dr. V.R. Chaudhari – 5- Papers
 2. Dr. V.G. Chaudhari – 9- Papers
 3. Dr. V.H. Upadhyay – 9- Papers
 - * Monographs - Nil
 - * Chapters in Books - Nil
 - * Edited Books - Nil
 - * Books with ISBN with details of publishers - Nil
 - * Number listed in International Database (For e.g. Web of Science, Scopus, Humanities International Complete, Dare Database - International Social Sciences Directory, EBSCO host, etc.) - Nil
 - * Citation Index – range / average - Nil
 - * SNIP - Nil
 - * SJR - Nil
 - * Impact Factor – range / average - Nil
 - * h-index – Nil
23. Details of patents and income generated - N.A.
24. Areas of consultancy and income generated - N.A.
25. Faculty selected nationally / internationally to visit other laboratories / institutions / industries in India and abroad - Nil
26. Faculty serving in
- a) National committees - Dr. V.R. Chaudhari Working with BFI Referee board
 - b) International committees
 - c) Editorial Boards
 - d) any other (please specify)- Guj. State Basketball Association- Joint Secretary
27. Faculty recharging strategies (UGC, ASC, Refresher / orientation programs, workshops, training programs and similar programs).
Yes
28. Student projects – **N.A.**
- percentage of students who have done in-house projects including inter-departmental projects
 - percentage of students doing projects in collaboration with other universities / industry / institute
29. Awards / recognitions received at the national and international level by
- Faculty-Honoured by basketball of india as referee

- Doctoral / post doctoral fellows- N.A.
- Students – 6- Students were The Member of WIU basketball team got fourth place

30. Seminars/ Conferences/Workshops organized and the source of funding (national / international) with details of outstanding participants, if any.

N.A.

31. Code of ethics for research followed by the departments

N.A.

32. Student profile programme-wise:

Name of the Programme (refer to question no. 4)	Applications received	Selected		Pass percentage	
		Male	Female	Male	Female
B.P.Ed-2009-10 to 2013-14	72	50	22	98%	95.45%
M.P.Ed-2009-10 to 2013-14	119	88	31	100%	96.77%
M.Phil-2010-11 to 2013-14	79	68	11	95.58%^	81.81%

33. Diversity of students

Name of the Programme (refer to question no. 4)	% of students from the same university	% of students from other universities within the State	% of students from universities outside the State	% of students from other countries
B.P.Ed	38.46%	61.54%	-	-
M.P.Ed	31.03%	44.83%	24.14%	-
M.Phil	80.00%	20.00%	-	-

34. How many students have cleared Civil Services and Defence Services examinations, NET, SET, GATE and other competitive examinations? Give details category-wise.

Nil

35. Student progression

Student progression	Percentage against enrolled
UG to PG	31.03%
PG to M.Phil.	80.00%
PG to Ph.D.	20.00%

Student progression	Percentage against enrolled
Ph.D. to Post-Doctoral	
Employed <ul style="list-style-type: none"> • Campus selection • Other than campus recruitment 	
Entrepreneurs	

36. Diversity of staff

Percentage of faculty who are graduates	
of the same university	-
from other universities within the State	03
from universities from other States	-
from universities outside the country	-

37. Number of faculty who were awarded M.Phil., Ph.D., D.Sc. and D.Litt. during the assessment period

1. Dr. V.R. Chaudhari – 2011 Ph.D.
2. Dr. V.G. Chaudhari – 2011 Ph.D.
3. Dr. V.H. Upadhyay – 2011 Ph.D.

38. Present details of departmental infrastructural facilities with regard to

- a) Library - Yes
- b) Internet facilities for staff and students - Yes
- c) Total number of class rooms - 06
- d) Class rooms with ICT facility - 01
- e) Students' laboratories – Sport Science Lab, Anatomy Lab, Physiotherapy Lab
- f) Research laboratories - Sport Science Lab, Anatomy Lab, Physiotherapy Lab

39. List of doctoral, post-doctoral students and Research Associates – **N.A.**

- a) from the host institution/university
- b) from other institutions/universities

40. Number of post graduate students getting financial assistance from the university.

N.A.

41. Was any need assessment exercise undertaken before the development of new programme(s)? If so, highlight the methodology.

N.A.

42. Does the department obtain feedback from – **N.A.**

- a. faculty on curriculum as well as teaching-learning-evaluation? If yes, how does the department utilize the feedback?
- b. students on staff, curriculum and teaching-learning-evaluation and how does the department utilize the feedback?
- c. alumni and employers on the programmes offered and how does the department utilize the feedback?

43. List the distinguished alumni of the department (maximum 10)

N.A.

44. Give details of student enrichment programmes (special lectures / workshops / seminar) involving external experts. Nil
45. List the teaching methods adopted by the faculty for different programmes.
Conversation Method, Lecture Method, Multimedia Application, Imitation Method, Demonstration Method
46. How does the department ensure that programme objectives are constantly met and learning outcomes are monitored?
N.A.
47. Highlight the participation of students and faculty in extension activities.
N.A.
48. Give details of “beyond syllabus scholarly activities” of the department.
N.A.
49. State whether the programme/ department is accredited/ graded by other agencies? If yes, give details.
N.A.
50. Briefly highlight the contributions of the department in generating new knowledge, basic or applied.
N.A.
51. Detail five major Strengths, Weaknesses, Opportunities and Challenges (SWOC) of the department.
Strengths- 1. Best Sports Infrastructure available
2. Sports sciences labs
3. sports library as well as Infflibnet Connection of University
Weaknesses- 1. Lack of faculty
2. Lack of Advance sports Infrastructure
3. Lack of Fund Resources
Opportunities- 1. Possibility of job placements in variety of fields
Challenges- 1. Lack of job placements in local / State Governments
52. Future plans of the department.
Planning to Start Ph.D. on Regular Basis
Health Related Programme , Sport Laboratory

Evaluative Report of Yoga Centre

1. Name of the Department : Yoga Center
2. Year of establishment: 2005
3. Is the Department part of a School/Faculty of the university?
Part of Faculty of the University
4. Names of programmes offered (UG, PG, M.Phil., Ph.D., Integrated Masters; Integrated Ph.D., D.Sc., D.Litt., etc.)
UG. = D.Y Ed., P.G= P.G.D.Y.Ed.
5. Interdisciplinary programmes and departments involved - N.A.-
6. Courses in collaboration with other universities, industries, foreign institutions, etc.
- N.A.-
7. Details of programmes discontinued, if any, with reasons
- N.A.-
8. Examination System: Annual/Semester/Trimester/Choice Based Credit System
D.Y.ed. – Annual P.G.D.Y.ed. Semester – C.B.C.S.
9. Participation of the department in the courses offered by other departments
M.Sc. C.A.& I.T. SEM.: VI - Yoga & Health , B.P.Ed.Sem.I Yoga & Health
M.B.A. – SEM.I - Yoga & Health , M.P.Ed. Sem.IV Yoga & Health
10. Number of teaching posts sanctioned, filled and actual (Professors/Associate Professors/Asst. Professors/others)

	Sanctioned	Filled	Actual (including CAS & MPS)
Professor	-	-	-
Associate Professors	-	-	-
Asst. Professors	-	-	-
Others	1	-	-

11. Faculty profile with name, qualification, designation, area of specialization, experience and research under guidance

Name	Qualification	Designation	Specialization	No. of Years of Experience	No. of Ph.D./ M.Phil. students guided for the last 4 years
Jagrutiben k.prajapati	B.COM.,B.P.Ed., M.P.Ed.,M.Phil. D.Y.Ed.,N.D.D.Y	CO.ORDINATOR	Yoga Education	9 years.	-

12. List of senior Visiting Fellows, adjunct faculty, emeritus professors

1. Dr.Kritbhai Patel
2. Dr.P.V.Chaudhary
3. Dr.G.U.Rajput
4. Dr.B.F.Chaudhary
5. Dr.Chirag Andhariya
6. Mr. Anil Patel
7. Mr. Barot
8. Mrs. Ketkiben

13. Percentage of classes taken by temporary faculty – programme-wise information
- N.A.-

14. Programme-wise Student Teacher Ratio 10:1

15. Number of academic support staff (technical) and administrative staff: sanctioned, filled and actual Not Available

16. Research thrust areas as recognized by major funding agencies
- N.A.-

17. Number of faculty with ongoing projects from a) national b) international funding agencies and c) Total grants received. Give the names of the funding agencies, project title and grants received project-wise.
- N.A.-

18. Inter-institutional collaborative projects and associated grants received

- a) National collaboration - N.A.-
- b) International collaboration - N.A.-

19. Departmental projects funded by DST-FIST; UGC-SAP/CAS, DPE; DBT, ICSSR, AICTE, etc.; total grants received. - N.A.-

20. Research facility / centre with

- a. state recognition - N.A.-
- b. national recognition -N.A.-
- c. international recognition -N.A.-

21. Special research laboratories sponsored by / created by industry or corporate bodies
-N.A.-

22. Publications:

- Number of papers published in peer reviewed journals (national / international)
 - 1. Jagrutiben k.prajapati = 5
- Monographs - Nil
- Chapters in Books - Nil
- Edited Books - Nil
- Books with ISBN with details of publishers - Nil
- Number listed in International Database (For e.g. Web of Science, Scopus, Humanities International Complete, Dare Database - International Social Sciences Directory, EBSCO host, etc.) - Nil
- Citation Index – range / average - Nil
- SNIP - Nil
- SJR - Nil
- Impact Factor – range / average - Nil
- h-index - Nil

23. Details of patents and income generated -N.A.-

24. Areas of consultancy and income generated -N.A.-

25. Faculty selected nationally / internationally to visit other laboratories / institutions

/industries in India and abroad -N.A.-

26. Faculty serving in

- a) National committees : J. k.Prajapati working with yoga Assosiation
- b) International committees
- c) Editorial Boards
- d) any other (please specify) : Working with Arya Samaj Trust

27. Faculty recharging strategies (UGC, ASC, Refresher / orientation programs, workshops, training programs and similar programs).

YES,

J.K.Prajapati – 4 Programmes

28. Student projects -N.A.-

- a. percentage of students who have done in-house projects including inter-departmental projects -N.A.-
- b. percentage of students doing projects in collaboration with other universities
 - 1. industry / institute -N.A.-

29. Awards / recognitions received at the national and international level by
- c. Faculty -N.A.-
 - d. Doctoral / post doctoral fellows -N.A.-
 - e. Students : Yoga Janural Morning class Student = Patel Harsha
National Yoga Comptitation =U=19=First

2.International Yoga Comptitation=U=19=Third

30. Seminars/ Conferences/Workshops organized and the source of funding (national international) with details of outstanding participants, if any.
-N.A.-

31. Code of ethics for research followed by the departments
-N.A.-

32. Student profile programme-wise: 2011-2014

Name of the Programme (refer to question no. 4)	Applications Received	Selected		Pass percentage		
		Male	Female	Male	Female	
D.Y.Ed.	2009-10	20	12	01	100%	100%
	2010-11	20	06	04	100%	100%
	2011-12	18	10	05	100%	100%
	2012-13	15	10	01	100%	100%
	2013-14	10	09	00	100%	100%
P.G.D.Y.ED.	2011-12	15	08	02	100%	100%
	2012-13	10	03	03	100%	100%
	2013-14	10	05	01	100%	100%

Diversity of students

33. -N.A.-

Name of the Programme (refer to question no. 4)	% of students from the same university	% of students from other universities within the State	% of students from universities outside the State	% of students from other countries
-	-	-	-	-
-	-	-	-	-

34. How many students have cleared Civil Services and Defense Services examinations, NET, SET, GATE and other competitive examinations? Give details category-wise.

- N.A.-

35. Student progression

Student progression	Percentage against enrolled
UG to PG	-
PG to M.Phil.	-

PG to Ph.D.	-
Ph.D. to Post-Doctoral	-
Employed	
<input type="checkbox"/> Campus selection	-
<input type="checkbox"/> Other than campus recruitment	-
Entrepreneurs	-

36. Diversity of staff

Percentage of faculty who are graduates	
of the same university	100%
from other universities within the State	-
from universities from other States	-
from universities outside the country	-

37. Number of faculty who were awarded M.Phil., Ph.D., D.Sc. and D.Litt. during the assessment period

Jagrutiben k.Prajapati - 2012-13 M.Phil. (Phy.Edu.)

38. Present details of departmental infrastructural facilities with regard to

- a. Library available
- b. Internet facilities for staff and students -NO-
- c. Total number of class rooms 1 CLASS ROOMS
- d. Class rooms with ICT facility 1 CLASS ROOMS
- e. Student s' Laboratorise -NO-
- f. Research laboratories -NO-

39. List of doctoral, post-doctoral students and Research Associates

- a. from the host institution/university -N.A.-
- b. from other institutions/universities -N.A.-

40. Number of post graduate students getting financial assistance from the university.
-N.A.-

41. Was any need assessment exercise undertaken before the development of new programme(s)? If so, highlight the methodology.

-N.A.-

42. Does the department obtain feedback from

- i. faculty on curriculum as well as teaching-learning-evaluation? If yes, how does the department utilize the feedback? -N.A.-

- ii. students on staff, curriculum and teaching-learning-evaluation and how does the department utilize the feedback? -N.A.-
- iii. alumni and employers on the programmes offered and how does the department utilize the feedback? -N.A.-
43. List the distinguished alumni of the department (maximum 10)
-N.A.-
44. Give details of student enrichment programmes (special lectures / workshops / seminar) involving external experts.
Workshop (Yogashibir) =
2009-10=33 2010-11=35 2011-12=24 2012-13=23 2013-14=24
45. List the teaching methods adopted by the faculty for different programmes.
1.Contact teaching 2.Self-demonstration 3.Charts teaching
4. Use of multi-media 5. Hard copy of otherteaching materials
46. How does the department ensure that programme objectives are constantly met and learning outcomes are monitored?
47. Highlight the participation of students and faculty in extension activities.
Faculty = Jagrutiben K.Prajapati- Morning Yoga Class General public
48. Give details of “beyond syllabus scholarly activities” of the department.
-N.A.-
49. State whether the programme/ department is accredited/ graded by other agencies? If yes, give details.
-N.A.-
50. Briefly highlight the contributions of the department in generating new knowledge, basic or applied.
-N.A.-
51. Detail five major Strengths, Weaknesses, Opportunities and Challenges (SWOC) of the department.
1. Strengths ☺ (i.) Best Yoga Hall (ii.) Rich Library (iii.) Good Instruments
2. Weakness :- (i.) No Internet Facility (ii.) No Sepret Class-room
(iii.) lack of Practical lab
3. Opportunities☺
(i.) Become Yoga Instructor
ii.) Act As Expert In Industries and other Institutes
(iii.) Establish Health Club
(iv.) Work with Physiotherapist
(v.) Work in mental Hospital
(vi.) Work as Yoga Instrucator in School and Colleges as well as SAG
-Possibility of Job Placements in variable of fields.
4. Challenges :-
(i.) Not recognised as yet as UG/PG Programes

- (ii.) No research is done at M.phil or Ph.D Level or Separately
- (iii.) Yoga therapy started be separated Para medical faculty.

52. Future plans of the department.

- (i.) To make Independant Dep. / Center and Its Separat build
- (ii.) To start UG / PG (granted) Cources
- (iii.) To Start M.Phil and Ph.D.
- (iv.) To carry out Separats research work
- (v.) To work various dissies therapy.

Evaluative Report of S K College of Business Management

1. Name of the Department BBA/ B.COM (S.K. COLLEGE OF BUSINESS MANAGEMENT)
2. Year of establishment JULY - 2007
3. Is the Department part of a School/Faculty of the university? University constitute College
4. Names of programmes offered (UG, PG, M.Phil., Ph.D., Integrated Masters; Integrated Ph.D., D.Sc., D.Litt., etc.) UG – B.B.A/ B.COM/ B. VOC, COMMUNITY COLLEGE
5. Interdisciplinary programmes and departments involved : NA
6. Courses in collaboration with other universities, industries, foreign institutions, etc.
In collaboration with ICWAI offers professional course.
7. Details of programmes discontinued, if any, with reasons NA
8. Examination System: Semester /Choice Based Credit System
9. Participation of the department in the courses offered by other departments NA
10. Number of teaching posts sanctioned, filled and actual (Professors/Associate Professors/Asst. Professors/others)

	Sanctioned	Filled	Actual (including CAS & MPS)
Professor	-	-	-
Associate Professors	-	-	-
Asst. Professors	7	7	7

11. Faculty profile with name, qualification, designation, area of specialization, experience and research under guidance

Name	Qualification	Designation	Specialization	No. of Years of Experience	No. of Ph.D./ M.Phil. students guided for the last 4 years
Dr. Ashwin G. Modi	Ph. D,MBA, BBA	Coordinator	Finance	6	
Mr. Mitul M. Deliya	Ph.D (Pursuing) MBA(Marketing), B.Sc UGC - NET	Asst. Professor	Marketing	6	NA
Ms. Riddhi G. Agrawal	Ph.D (Pursuing) MBA(Finance), B.Com, M.Com	Asst. Professor	Finance	6	NA
Mrs. Kavita A. Trivedi	Ph.D (Pursuing) MBA(Finance), B.Com	Asst. Professor	Marketing	5	NA
Mr. Bharat D. Prajapati	Ph.D (Pursuing) MBA(Finance), B.Com UGC - NET	Asst. Professor	Finance	5	NA
Mr. Anand A. Patel	Ph.D (Pursuing) MBA(Marketing), B.Pharma	Asst. Professor	Marketing	5	NA
Mrs. Payal P. Barot	MBA(Finance), B.Com	Asst. Professor	Finance	5	NA
Mr. Jay Y. Trivedi	Ph.D (Pursuing) MBA(Marketing), B.Sc	Asst. Professor	Marketing	5	NA

12. List of senior Visiting Fellows, adjunct faculty, emeritus professors NA
13. Percentage of classes taken by temporary faculty – programme-wise information NA

14. Programme-wise Student Teacher Ratio
 BBA - 14:1
 B.COM – 23:1
15. Number of academic support staff (technical) and administrative staff: sanctioned, filled and actual :

Name	Qualification	Designation	No. of Years of Experience
Mr. Mohd. Mohdsinhusen K. Faruki	PGDCA, B.com	Computer operator Cum Clerk	7
Mr. Mahesh J. Prajapati	BA, M.Lib	Librarian	7
Mrs. Hetal R. Modi	MCA , PGDCA ,BCOM	Lab Assistant	3
Mr. Dashrath J. Thakor	8 th standard	PEON	6
Mr. Suresh P. Thakor	8 th standard	PEON	6

16. Research thrust areas as recognized by major funding agencies
17. Number of faculty with ongoing projects from a) national b) international funding agencies and c) Total grants received. Give the names of the funding agencies, project title and grants received project-wise.
- (1) Major Research Project (Project Director)
 Title :- Women Rights violation in Patan District
 Funded By :- Indian Council of Social Science
 Research
 Amount :- Rs. 5,08,275/-
 Duration :- One Year
 Commencement Date :- 01 / 05 / 2012 (Ongoing)
- (2) Minor Research Project (Co-Principal Investigator)
 Title :- Impact of Sakhi Mandal Yojana on Women
 Empowerment
 Funded By :- University Grants Commission
 Amount :- Rs. 1,30,000/-
 Duration :- One Year
 Commencement Date: - 01 / 05 / 2012 (Ongoing)

Carbon Finance: Scope for the sustainable development of India	Asian Journal of Research in Banking and Finance	Asian Research Consortium	2249-7323	3		2013-14	1.1
Forest Management Systems and Community-Based Forestry: A case of Sabharkantha (South) Forest Division of Gujarat state	IJSR - INTERNATIONAL JOURNAL OF SCIENTIFIC RESEARCH	INTERNATIONAL JOURNAL OF SCIENTIFIC RESEARCH	ISSN No 2277-8179	Volume : 2 Issue : 9	217-219	2013-14	0.33
Study the Carbon Emission around the globe with Special reference to India	An International Research Journal of Environmental Science	Current World Environment	0973-4929	3		2013-14	1.01
Study the growth and Trend of Carbon Market in India	Global Journal of Research Analysis	Global Research Analysis	2277-8160	2		2013-14	

Environmental Clearance: Daunting Challenge & Mystifying Signal To Stakeholders Of India	International Journal Of Social Science & Interdisciplinary Research, (IJSSIR)	International Journal Of Social Science & Interdisciplinary Research, (IJSSIR)	ISSN 2277 3630	1	156	2012-13	
Non-Timber Forest Products in Sustainable Forest Management	Science Research Network (SSRN),	Social Science Electronic Publishing [USA]				2012-13	

Mr. Mitul M Deliya

Title of Research Paper	Journal name	Name of Publisher	ISSN No	Volume No (Issue)	Page No	Year of Publication	Impact Factor
Awariness of Micro Insurance Product in Patan District	Abhinav	Abhinav Seva Mandal Trust	2277-1166	1	16-35	2012-13	0.97
Commercial exploitation, economic development and intellectual property rights	International Journal of Research in Engineering, IT and SocialSc.	Indus Foundation for Education, Research and Social Welfare	2250-0588	2 (11)	363-368	2012-13	

Consumer Behavior towards the new packaging of FMCG Products	Abhinav	Abhinav Seva Mandal Trust	2277-1166	1	199-211	2012-13	0.97
Effect of physical Training on Selectyed Physiological variables of Intellectually Challenged Children	International Journal of Research in Engineering, IT and Social Sciences	Indus Foundat ion for Educati on, Researc h and Social Welfare	2250-0588	2	57-61	2012-13	
Impact of organized retailers on Unorganized retailers	International Journal of Research in Management, Economics & Commerce	Online Journal	2250-057X	2	64-83	2012-13	
Negative impact of advertisement on women with specific focus on FMCG Products - Patan District	Global Journal of Management and Business Research	Global Journal Inc.(US A)	2249-4588, 0975-5853 (Print)	12		2012-13	
Role of Packaging on Consumer Buying Behavior - Patan District	Global Journal of Management and Business Research	Global Journal Inc.(US A)	2249-4588, 0975-5853 (Print)	12		2012-13	

Consumer Attitudes towards foreign retailers products	Journal of Commerce and Management Thought	SSK Busilink	0975-623X	2		2011-12	
Hemchandracharyana Dravyashay Mahakavya manirupati aarthik vyavasthanu aadhunik drashtiyemulyankan	HAIM-PRAPA	Department of Sanskrit and Bharatiya Vidhya, HNGU, Patan	2250-3064	3	247-250	2011-12	
Hemchandracharyana Dravyashay Mahakavya manirupati aarthik vyavasthanu aadhunik drashtiyemulyankan	HAIM-PRAPA	Department of Sanskrit and Bharatiya Vidhya, HNGU, Patan	2250-3064	3	247-250	2011-12	
Investment pattern of investors in Life insurance companies	International Journal of Research in Management	Online Journal	2249-5908	2	181-194	2011-12	
Study of Vital purchase criteria of customers while selecting DTH services in North Gujarat Region	Proficient	Proficient	0975-475X	3	9	2011-12	
Consumer attitudes towards foreign retailers	Journal of Commerce and		(Print) 0975-623X	2	266 to 28	2010-11	

products, April - June, 2011	Management Thought		(Online) 0976-478X		0		
------------------------------	--------------------	--	-----------------------	--	---	--	--

Ms. Riddhi G Agrawal

Title of Research Paper	Journal name	ISSN No	Volume No (Issue)	Page No	Year of Publication
Impact of 6th pay in the hands of employees with effect to the inflation	IES International Finance conference Journal	0974-5467			2012-13

Mrs. Kavita A Trivedi

Title of Research Paper	Journal name	Name of Publisher	ISSN No	Volume No (Issue)	Page No	Year of Publication	Impact Factor
Best HR Practices	Paripex - The Journal of all Subjects		2250-1991			2012-13	
Reasons after the war of going Green - Green Marketing	Indian Journal of Applied Research		2249-555X			2012-13	
Socio Cultural issues in marketing	Global research analysis	GRA	2277-8160	1(1)	66-67	2012-13	0.27
Emergence of Indian retail industry-	The journal of management and co-operation	The journal of management and co-operation	VIII -	V-III (3)	37	2011-12	

trends, prospects and challenges							
Rural Marketing Practices in India – Emerging Issues	International Journal of Scientific Research	IJSR	227 7- 817 9	1(1)	78- 79	2008-09	0.33

Mr. Jay Y Trivedi

Title of Research Paper	Journal name	Name of Publisher	ISSN No	Volume No (Issue)	Page No	Year of Publication	Impact Factor
A Study on Marketing Strategies of Small and Medium sized Enterprises	Research Journal of Management Sciences	International Science Congress Association Journal of Management Sciences	ISSN: 2319-1171	vol 2(8)	20-22	2013-14	
Forest Management Systems and Community-Based Forestry: A case of Sabharkantha (South) Forest Division of Gujarat	IJSR - INTERNATIONAL JOURNAL OF SCIENTIFIC RESEARCH	INTERNATIONAL JOURNAL OF SCIENTIFIC RESEARCH	ISSN No 2277-8179	Volume : 2 Issue : 9	217-219	2013-14	0.33

state							
Analyzing Symbiotic Marketing Models and Strategies in customer consumption value chain	International Journal of Scientific Research	International Journal of Scientific Research	227 7- 817 9	2 (12)	56 - 59	2012- 13	0.33
Environmental Clearance: Daunting Challenge & Mystifying Signal To Stakeholders Of India	International Journal Of Social Science & Interdisciplinary Research, (IJSSIR)	International Journal Of Social Science & Interdisciplinary Research, (IJSSIR)	ISS N 227 7 363 0	1	15 6	2012- 13	
Non-Timber Forest Products in Sustainable Forest Management	Science Research Network (SSRN),	Social Science Electronic Publishing [USA]				2012- 13	
Modern HR Practices(Under National Rural Health Mission, Government of	Pacific Business Review International, A Refereed Quarterly International Journal of Management (ISSN: 0974-	Pacific Business Review International	(ISS N: 097 4- 438 X)	4	10 9	2011- 12	

Gujarat).	438X)						
-----------	-------	--	--	--	--	--	--

Mr. Bharat D Prajapati

Title of Research Paper	Journal name	Name of Publisher	ISSN No	Volume No (Issue)	Page No	Year of Publication	Impact Factor
Impact of Information technology on Banking	International Research Journal of Management, Sociology and Humanities	IRJMSH	Online ISSN 2277-9809	4(3)	1046-1052	2013-14	0.98
Money laundering and Indian Financial Institutions	International Research Journal of Management Science & Technology	International Research Journal of Management Science & Technology	Online ISSN 2250-1959	4 (2)		2013-14	0.61
The Integrated Approach to Management of NPAs in AXIS Bank	IRJMSH	IRJMSH	2277-9809	4 issue 2	1060-1071	2013-14	0.98
PERFORMANCE OF THE INDIAN MUTUAL FUND INDUSTRY: IMPERICAL STUDY OF	RJSSM	The International Journal Research Publications	ISSN : 2251-1571	Vol 2 (11)	124-128	2012-13	3.45

DIVERSIFIED EQUITY SCHEMES							
Consumer attitudes towards foreign retailers products	Journal of Commerce and Management Thought					2011-12	
Evaluation of Economic arrangement by Modern way included in Dravyashay Epic of Hemchandracharya.	HAIM-PRAPA-A Research Journal of Dept. of Sanskrit & Bharativila, HNGU, Patan		2250-3064,			2011-12	
Hemchandracharyana Dravyashay Mahakavya manirupati aarthik vyavasthanu aadhunik drashtiyemulyankan	HAIM-PRAPA	Department of Sanskrit and Bharativila Vidhya, HNGU, Patan	2250-3064	3	247-250	2011-12	

- Monographs NA
- Chapters in Books Nil
- Edited Books Nil
- Books with ISBN with details of publishers

Mr. Mitul M Deliya

No	Title of Book and Book Chapter	ISBN No	Name of Publisher	Year
1	Female Consumer Behavior	978-3-659-22185-9	Lambert Academy Publication, Germany	2012-13
2	Impact of 3G Technology in India	978-3-659-18179-5	Lambert Academy Publication, Germany	2012-13
3	Retail Revolution	978-3-659-	Lambert Academy	2012-

		17042-3	Publication, Germany	13
4	Studies in Business Practices [Chapter Edited] SSK Busilink, Pune March,2012	978-3-8443- 1503-5,	Micro Insurance Lambert Academy Publication, Germany	2012- 13
5	Consumer Ethnocentrism	978-81- 9225796-0-2	SSK BUSILINK, Pune	2011- 12
6	Micro Insurance	978-3-8443- 1503-5	Lambert Academy Publication, Germany	2011- 12
7	Retail Revolution	978-3-659- 17042-3,	Lambert Academy Publication, Germany	2011- 12
8	Female Consumer Behavior	978-3-659- 22185-9 2012	Lambert Academy Publication, Germany	2008- 09
9	Impact of 3G Technology in India	978-3-659- 18179-5	Lambert Academy Publication, Germany	2008- 09

- Number listed in International Database (For *e.g.* Web of Science, Scopus, Humanities International Complete, Dare Database - International Social Sciences Directory, EBSCO host, etc.)
- Citation Index – range / average Nil
- SNIP NA
- SJR NA
- Impact Factor – range / average Nil
- h-index NA

23. Details of patents and income generated NA

24. Areas of consultancy and income generated NA

25. Faculty selected nationally / internationally to visit other laboratories / institutions industries in India and abroad NA

26. Faculty serving in NA

- a) National committees b) International committees c) Editorial Boards d) any other (please specify)

27. Faculty recharging strategies (UGC, ASC, Refresher / orientation programs, workshops, training programs and similar programs).

- At a moment we allow any two faculties to undergo UGC Refresher / orientation programs, workshops, training programs and similar programs
- Every faculty is undergone UGC Orientation Program from various ASCs.

- Also some of our faculties have undergone STC courses from various ASCs.

28. Student projects NA

- percentage of students who have done in-house projects including inter-departmental projects
100% students in Sem - VI undergo live project.
- percentage of students doing projects in collaboration with other universities / industry / institute
100% student in Sem - VI undergo live project with industry.

29. Awards / recognitions received at the national and international level by NA

- Faculty
- Doctoral / post doctoral fellows
- Students

30. Seminars/ Conferences/Workshops organized and the source of funding (national /international) with details of outstanding participants, if any.

National workshop on Analytical software “SPSS” in association with ICSSR, New Delhi

31. Code of ethics for research followed by the departments Yes

32. Student profile programme-wise:

Name of the Programme (refer to question no. 4)	Applications received	Selected		Pass percentage	
		Male	Female	Male	Female
BBA SEM-II	34	20	14	17	7
BBA SEM-IV	50	35	15	32	14
BBA SEM-VI	93	64	29	58	29
B.COM SEM-II	51	28	23	19	16

34. How many students have cleared Civil Services and Defence Services examinations, NET, SET, GATE and other competitive examinations? Give details category-wise.

- 5 Students have passed different exams by Government of Gujarat and absorbed in Tax, Revenue, Audit departments.

- Students have passed IBPS Bank PO Exam and absorbed in various nationalized banks.

35. Student progression

Student progression	Percentage against enrolled
UG to PG	96%
PG to M.Phil.	As department offers UG program - NA
PG to Ph.D.	As department offers UG program – NA
Ph.D. to Post-Doctoral	As department offers UG program – NA
Employed <input type="checkbox"/> Campus selection <input type="checkbox"/> Other than campus recruitment	4 to 5 students every year Opt for PG study
Entrepreneurs	Details Not Available

36. Diversity of staff

Percentage of faculty who are graduates	7
of the same university	7
from other universities within the State from universities	0
from other States from universities outside the country	0

37. Number of faculty who were awarded M.Phil., Ph.D., D.Sc. and D.Litt. during the assessment period

No faculty has awarded

38. Present details of departmental infrastructural facilities with regard to

a) Library	Yes
b) Internet facilities for staff and students	Yes
c) Total number of class rooms	6
d) Class rooms with ICT facility	6
e) Students' laboratories	1
f) Research laboratories	NA

39. List of doctoral, post-doctoral students and Research Associates NA

- a) from the host institution/university
- b) from other institutions/universities

40. Number of post graduate students getting financial assistance from the university. NA

Was any need assessment exercise undertaken before the development of new programme(s)? If so, highlight the methodology.

41. Does the department obtain feedback from

- a. faculty on curriculum as well as teaching-learning-evaluation? If yes, how does the department utilize the feedback? No
- b. students on staff, curriculum and teaching-learning-evaluation and how does the department utilize the feedback? No
- c. alumni and employers on the programmes offered and how does the department utilize the feedback? No

42. List the distinguished alumni of the department (maximum 10)

Not Available

Give details of student enrichment programmes (special lectures / workshops / seminar) involving external experts.

Every year Department organize state level competition "Wisdom" in which participants from across state are invited to participate in various events like Quiz, Debate, Ad mad Show and Elocution, such event helps students to understand latest trends in market, stimulate the competitive level among them, and various other personality development aspects.

43. List the teaching methods adopted by the faculty for different programmes.

Audio Visual Teaching Aids
Laboratory Teaching
Presentations & Group discussion

44. How does the department ensure that programme objectives are constantly met and learning outcomes are monitored?

As Exam and Study program under go Choice Based Credit System

45. Highlight the participation of students and faculty in extension activities. NA

48. Give details of “beyond syllabus scholarly activities” of the department.

Blood Donation Camp at department
Aptitude enhancement by organizing State Level program “WISDOM”
Cultural Activities at Departments
Day Celebrations

49. State whether the programme/ department is accredited/ graded by other agencies? If yes, give details. NO

50. Briefly highlight the contributions of the department in generating new knowledge, basic or applied.

Aptitude enhancement by organizing State Level program “WISDOM” which will enhance knowledge & employability of students

51. Detail five major Strengths, Weaknesses, Opportunities and Challenges (SWOC) of the department.

Strengths

- Full Permanent Staff
- Own departmental library having books 6746 costing Rs.2199542 Also subscription of 18 different magazines.
- Air-conditioned computer lab with all latest configuration computers.
- Wi-Fi enabled college Campus which enables students to Wi-Fi for enhancement of their knowledge.
- Audio visual – Studio Class room with projectors.
- Website of college
- Pioneers in offering professional diploma courses which is enhancing employability of students
 - Advance diploma in Banking and Insurance
 - Advance diploma in Tourism Management
 - Advance diploma in Financial Services
 - Advance diploma in Mobile communication

- ICWAI study centre

Weakness

- Student's aptitude towards study is not favorable.
- Course is demanding professional aptitude, but student's approach towards English is not good.
- Lack of interest among the students to appear for competitive examinations.
- University is geographically speared in five districts of north Gujarat where industry is not available and Do not have enough placement activities

Opportunities

- More collaboration with Indian and Foreign universities can be done so as to benefits students.
- The new learning of the age requires greater proficiency in soft skills among students. The College has the necessary technical and infrastructural resources to take this to a higher level.
- Strengthening Alumni Activities.
- Strengthening academia-industry linkages
- To introduce Digital Library.
- To involve the staff in research activity.
- Student's progression chart is to be developed.

Challenges

- An increase in the number of degree colleges in and around PATAN.
- Some students are diverted towards Distance Mode of Education.
- Rural community shows negative attitude towards employability.
- Parents unwilling to admit their wards for traditional courses in Arts and Commerce.

52. Future plans of the department.

- Stress on research especially in the field of local culture and socioeconomic problems of the neighboring local communities.
- To train students to master the basics of the subject and improve their soft skills through several interactive sessions.
- To motivate teachers to guide undergraduate students for research projects.

Evaluative Report of the Department of Social Work

1. Name of the Department : Department Of Social Work
2. Year of establishment : 2000
3. Is the Department part of a School/Faculty of the university? : Faculty
4. Names of programmes offered (UG, PG, M.Phil., Ph.D., Integrated Masters; Integrated Ph.D., D.Sc., D.Litt., etc.) : UG and PG
5. Interdisciplinary programmes and departments involved : No
6. Courses in collaboration with other universities, industries, foreign institutions, etc. : No
7. Details of programmes discontinued, if any, with reasons : ---
8. Examination System: Annual/Semester/Trimester/Choice Based Credit System
9. Participation of the department in the courses offered by other departments : ---
10. Number of teaching posts sanctioned, filled and actual (Professors/Associate Professors/Asst. Professors/others)

	Sanctioned	Filled	Actual (including CAS & MPS)
Professor	--	--	--
Associate Professors	--	--	--
Asst. Professors	MSW	3	--
Others(Teaching ass)	BSW	3	--

11. Faculty profile with name, qualification, designation, area of specialization, experience and research under guidance

Name	Qualification	Designation	Specialization	No. of Years of Experience	No. of Ph.D./ M.Phil. students guided for the last 4

					years
Dr. G. N. Raval	M.S.W, Ph.D	Asst. Professor	Social Work	12	--
Dr.Roshan Agrawal	M.S.W, Ph.D	Asst. Professor	Social Work	10	
Dr.Nisha Patel	M.S.W, Ph.D	Asst. Professor	Social Work	12	

12. List of senior Visiting Fellows, adjunct faculty, emeritus professors : ---
13. Percentage of classes taken by temporary faculty – programme-wise information:
10
14. Programme-wise Student Teacher Ratio : MSW 36-1, BSW 25-1
15. Number of academic support staff (technical) and administrative staff: sanctioned, filled and actual : 1 Clerk, 1 Peon
16. Research thrust areas as recognized by major funding agencies
17. Number of faculty with ongoing projects from a) national b) international funding agencies and c) Total grants received. Give the names of the funding agencies, project title and grants received project-wise. : ---
18. Inter-institutional collaborative projects and associated grants received : ---
- a) National collaboration b) International collaboration
19. Departmental projects funded by DST-FIST; UGC-SAP/CAS, DPE; DBT, ICSSR, AICTE, etc.; total grants received.
UGC (Dr. Gargiben Raval) 1,50,000 2012-13
20. Research facility / centre with : ---
- state recognition
 - national recognition
 - international recognition
21. Special research laboratories sponsored by / created by industry or corporate bodies
22. Publications:
- * Number of papers published in peer reviewed journals (national / international) : 4 + 4 + 5

- * Monographs
- * Chapters in Books : 1+1
- * Edited Books
- * Books with ISBN with details of publishers : 2+2
- * Number listed in International Database (For *e.g.* Web of Science, Scopus, Humanities International Complete, Dare Database - International Social Sciences Directory, EBSCO host, etc.)
- * Citation Index – range / average
- * SNIP --NA
- * SJR --NA
- * Impact Factor – range / average :NA
- * h-index : --NA

23. Details of patents and income generated : No

24. Areas of consultancy and income generated : No

25. Faculty selected nationally / internationally to visit other laboratories / institutions / industries in India and abroad : No

26. Faculty serving in

- a) National committees
- b) International committees
- c) Editorial Boards
- d) any other (please specify)

27. Faculty recharging strategies (UGC, ASC, Refresher / orientation programs, workshops, training programs and similar programs).

28. Student projects

- percentage of students who have done in-house projects including inter-departmental projects : No
- percentage of students doing projects in collaboration with other universities /industry / institute : No

29. Awards / recognitions received at the national and international level by

- Faculty : No
- Doctoral / post doctoral fellows
- Students

30. Seminars/ Conferences/Workshops organized and the source of funding (national /international) with details of outstanding participants, if any. : No

31. Code of ethics for research followed by the departments : Yes

32. Student profile programme-wise:

Name of the Programme (refer to question no. 4)	Applications received	Selected		Pass percentage	
		Male	Female	Male	Female
BSW (U.G)	Online	08	13		
MSW (P.G)	"	22	29		

33. Diversity of students

Name of the Programme (refer to question no. 4)	% of students from the same university	% of students from other universities within the State	% of students from universities outside the State	% of students from other countries
BSW (U.G)	--	--	--	--
MSW (P.G)	30	21	--	--

34. How many students have cleared Civil Services and Defense Services examinations, NET, SET, GATE and other competitive examinations? Give details category-wise.

NIL

35. Student progression

Student progression	Percentage against enrolled
UG to PG	25 %
PG to M.Phil.	--
PG to Ph.D.	--
Ph.D. to Post-Doctoral	--
Employed	--
<input type="checkbox"/> Campus selection	

<input type="checkbox"/> Other than campus recruitment	
Entrepreneurs	--

36. Diversity of staff

Percentage of faculty who are graduates	
of the same university	83%
from other universities within the State	17%
from universities from other States from	--
universities outside the country	--

37. Number of faculty who were awarded M.Phil., Ph.D., D.Sc. and D.Litt. during the assessment period : Ph.D - 3 / M.Phil - 1

38. Present details of departmental infrastructural facilities with regard to

- a) Library : No
- b) Internet facilities for staff and students : No
- c) Total number of class rooms : 05
- d) Class rooms with ICT facility : No
- e) Students' laboratories : No
- f) Research laboratories : No

39. List of doctoral, post-doctoral students and Research Associates

- a) from the host institution/university --NIL--
- b) from other institutions/universities --NIL--

40. Number of post graduate students getting financial assistance from the university. -NIL

41. Was any need assessment exercise undertaken before the development of new programme(s)? If so, highlight the methodology. -NIL

42. Does the department obtain feedback from

- a. faculty on curriculum as well as teaching-learning-evaluation? If yes, how

does the department utilize the feedback? : Unit Test

- b. students on staff, curriculum and teaching-learning-evaluation and how does the department utilize the feedback? : No
 - c. alumni and employers on the programmes offered and how does the department utilize the feedback? : Yes
43. List the distinguished alumni of the department (maximum 10) : Yes
44. Give details of student enrichment programmes (special lectures / workshops / seminar) involving external experts. : Yes
45. List the teaching methods adopted by the faculty for different programmes. : Yes
46. How does the department ensure that programme objectives are constantly met and learning outcomes are monitored? : Yes
47. Highlight the participation of students and faculty in extension activities.
- General Awareness Program in Rural Based in Field (Health, Education, Addiction) by Really, Street Play, Group Meeting
 - Personal, Family & Community Problem Solving Process.
48. Give details of “beyond syllabus scholarly activities” of the department.
- Target group intervention celebration on Brest feeding week heritage touring unday"
49. State whether the programme/ department is accredited/ graded by other agencies? If yes, give details. : No
50. Briefly highlight the contributions of the department in generating new knowledge, basic or applied.
- 1. Setu Program 2. Invite expert 3. Motivational tour 4. Tribal Camp
51. Detail five major Strengths, Weaknesses, Opportunities and Challenges (SWOC) of the department. : Dearth of Faculty
52. Future plans of the department.

M.Phil Department
Government Job Preparation
Campus Interview
Model Village

Evaluative Report of Jain Academic Education Research Centre

1. Name of the Department Jain Academic Education Research centre
2. Year of establishment 20012-13
3. Is the Department part of a School/Faculty of the university? - University
4. Names of programmes offered (UG, PG, M.Phil., Ph.D., Integrated Masters; Integrated Ph.D., D.Sc., D.Litt., etc.) U.G.
5. Interdisciplinary programmes and departments involved -
6. Courses in collaboration with other universities, industries, foreign institutions, etc. -
7. Details of programmes discontinued, if any, with reasons -
8. Examination System: Annual/Semester/Trimester/Choice Based Credit System Semester
9. Participation of the department in the courses offered by other departments -
10. Number of teaching posts sanctioned, filled and actual (Professors/Associate Professors/Asst. Professors/others)

	Sanctioned	Filled	Actual (including CAS & MPS)
Professor			
Associate Professors			
Asst. Professors		01	

11. Faculty profile with name, qualification, designation, area of specialization, experience and research under guidance

Name	Qualification	Designation	Specialization	No. of Years of Experience	No. of Ph.D./ M.Phil. students guided for the last 4 years
Dr Sumanben A.Thakker	M.A. Ph.D.	Associate Professor.	Prakrit	31	-

12. List of senior Visiting Fellows, adjunct faculty, emeritus professors -
13. Percentage of classes taken by temporary faculty – programme-wise informme-wise
15%
14. Programme-wise Student Teacher Ratio .-
15. Number of academic support staff (technical) and administrative staff: sanctioned, filled and actual - 01 Clerk
02 Peon
16. Research thrust areas as recognized by major funding agencies -
17. Number of faculty with ongoing projects from a) national b) international funding agencies and c) Total grants received. Give the names of the funding agencies, project title and grants received project-wise. -
18. Inter-institutional collaborative projects and associated grants received -
- a) National collaboration b) International collaboration
19. Departmental projects funded by DST-FIST; UGC-SAP/CAS, DPE; DBT, ICSSR, AICTE, etc.; total grants received. -
20. Research facility / centre with -
- state recognition
 - national recognition

- international recognition
21. Special research laboratories sponsored by / created by industry or corporate bodies - Nil
22. Publications: -
- Number of papers published in peer reviewed journals (national / international)
- Monographs Nil
 - Chapters in Books Nil
 - Edited Books Nil
 - Books with ISBN with details of publishers Nil
 - Number listed in International Database (For *e.g.* Web of Science, Scopus, Humanities International Complete, Dare Database - International Social Sciences Directory, EBSCO host, etc.) Nil
 - Citation Index – range / average Nil
 - SNIP Nil
 - SJR Nil
 - Impact Factor – range / average Nil
 - h-index Nil
23. Details of patents and income generated - Nil
24. Areas of consultancy and income generated - Nil
25. Faculty selected nationally / internationally to visit other laboratories / institutions /industries in India and abroad - Nil
26. Faculty serving in -
- a) National committees
 - b) International committees
 - c) Editorial Boards
 - d) any other (please specify)
27. Faculty recharging strategies (UGC, ASC, Refresher / orientation programs, workshops, training programs and similar programs). -Nil
28. Student projects -
- percentage of students who have done in-house projects including inter-departmental projects
 - percentage of students doing projects in collaboration with other universities / industry / institute

29. Awards / recognitions received at the national and international level by - Nil
- Faculty
 - Doctoral / post doctoral fellows
 - Students
30. Seminars/ Conferences/Workshops organized and the source of funding (national / international) with details of outstanding participants, if any. - Nil
31. Code of ethics for research followed by the departments -
32. Student profile programme-wise:

Name of the Programme (refer to question no. 4)	Applications received	Selected		Pass percentage	
		Male	Female	Male	Female
2012 – 13 Jai.Cer,course	23	13	10	100	100
2013-14 Jai. cer.Course	7	2	5	-	100
2013 – 2014 Dip.in Jai.	6	3	3	100	100

33. Diversity of students

Name of the Programme (refer to question no. 4)	% of students from the same university	% of students from other universities within the State	% of students from universities outside the State	% of students from other countries
2012 – 13 Jai.Cer.Course	-	-	-	-
2013-14 Dip.in Jai	-	-	-	-

34. How many students have cleared Civil Services and Defense Services examinations, NET, SET, GATE and other competitive examinations? Give details category-wise.

35. Student progression

Student progression	Percentage against enrolled
UG to PG	
PG to M.Phil.	
PG to Ph.D.	-
Ph.D. to Post-Doctoral	-
Employed <input type="checkbox"/> Campus selection <input type="checkbox"/> Other than campus recruitment	-
Entrepreneurs	-

36. Diversity of staff NA

Percentage of faculty who are	
graduates of the same university	
from other universities within the State universities from othe State	
100 % from universities outside the country	

37. Number of faculty who were awarded M.Phil., Ph.D., D.Sc. and D.Litt. during the assessment period -Nil

38. Present details of departmental infrastructural facilities with regard to

- a) Library -
- b) Internet facilities for staff and students -
- c) Total number of class rooms 4

- d) Class rooms with ICT facility -
 - e) Students' laboratories -
 - f) Research laboratories -
39. List of doctoral, post-doctoral students and Research Associates - Nil
- a) from the host institution/university
 - b) from other institutions/universities
40. Number of post graduate students getting financial assistance from the university. -NA
41. Was any need assessment exercise undertaken before the development of new programme(s)? If so, highlight the methodology. -
42. Does the department obtain feedback from
- a. faculty on curriculum as well as teaching-learning-evaluation? If yes, how does the department utilize the feedback? Nil
 - b. students on staff, curriculum and teaching-learning-evaluation and how does the department utilize the feedback? Nil
 - c. alumni and employers on the programmes offered and how does the department utilize the feedback? Nil
43. List the distinguished alumni of the department (maximum 10) -Nil
44. Give details of student enrichment programmes (special lectures / workshops / seminar) involving external experts. -Nil
45. List the teaching methods adopted by the faculty for different programmes. .
Class room teaching
46. How does the department ensure that programme objectives are constantly met and learning outcomes are monitored?
47. Highlight the participation of students and faculty in extension activities.
48. Give details of "beyond syllabus scholarly activities" of the department. -Nil
49. State whether the programme/ department is accredited/ graded by other agencies? If yes, give details. -Nil
50. Briefly highlight the contributions of the department in generating new

knowledge, basic or applied. -Nil

51. Detail five major Strengths, Weaknesses, Opportunities and Challenges (SWOC) of the department. -
Strength – Ample literature in subject within university
Weakness- Aptitude towards language is negative.
Opportunities – Scope of good research
Challenges – Qualified faculties
52. Future plans of the department. -
To Start modular courses.

University Library Profile

Introduction

The library was started along with the establishment of the University in the year 1986. The library was established on 15th January, 1988. Initially It was housed in the Gandhi Memorial Hall. The University received a donation of Rs.51 lakhs from Dr. M. S. Patel Trust, Mumbai for the construction of the library building, hence the library is named as Shivabhai Umedbhai Patel Library. The state government had also sanctioned Rs. 25 lakhs. Overall Rs. 85,69,616 has been spent for the construction of the two storied library building. The total built up area of the building is 2486.41 sq. meter. The Rotary Patan City has also donated Rs. 11.50 lakhs for library furniture, reading cabinets and books.

Late Dhanajibhai Bhabhaidas Patel (Jogivado, Patan) Smarnathe Library Fountain Donated Rs. 51000/- (Year 2001-2002).

Working Hours

Office Time: 10.30 A.M. - 6.10 P.M.

Reading Hall: 8.00 A.M. To 8.00 P.M. on Examination Period 10:00 P.M.

Stack Room : 8.00 A.M. To 8.00 P.M.

(2nd and 4th Saturday, Sunday and Holiday : 8.00 A.M. to 4.00 P.M.

Collection

Books	67,637
Dissertation	1,094
Theses	1,092
Back Volumes of The Periodicals	2,336
Audio / Video Cassettes	841
Current Periodicals	150
Special Collection	4252

It's annual budget for purchasing of books is Rupees 12,00,000 (University Budget), 23,00,000 (UGC Budget), 4,00,000 (E-Journals) and for periodicals is Rupees 3,00,000 (2010-2012) Total Rupees 2,85,13,882 has been spent for purchasing of the books. Year 2012-13 University Budget Books Rs. 12,00,000 Periodical Budget Rs. 3,00,000.

The library received the late Dr. B. J. Sandesara's personal library as a gratis. It contains about 4,252 books and some back volumes of literary and indological journals. The collection is very rich in the areas of Gujarati and

Sanskrit literature, History, Culture, Jainology and Indology. The library is also planning to build up a local history museum and Hemchandracharya a corner. Hemchandracharya was a versatile scholar and a great jainnologist of Patan (also known as Anhilwad Patan) who flourished in the 12th century. The documents are being classified according to D.D.C. and A.A.C.R.-II is followed for cataloguing.

Services

The library provides all the traditional services like Reference, Bibliographical, Literature search, User Education, Inter Library Loan, Photocopy, Audio Visual, Cyber Cafe-Internet, OPAC, Newspaper clipping, CAS, etc. Since last fifteen years the library is also organization weekly discussion group called 'Characha Vartula' for students. It meets every Wednesday hence called as Budhavariyu. Average 25-30 students are regularly attending it and discussion on various subjects.

Reprographic Services

The Shivabhai Umedbhai Patel Library reprography (Xerox) Service inside the Library to all its members.

Reading Hall

The Shivabhai Umedbhai Patel Library has Constructed a separate reading hall and kept open from 8.00 am to 10.30 pm. Students can bring their personal books and study in this hall without any disturbance. This Reading Hall has the capacity to accommodate 160 students at a time and it is being used extensively.

Research Room

The library has a separate Research Room with A.C facility. This Research Room has the capacity to accommodate 60 Researchers at a time.

Reference Section

The Library has constructed a separate reference hall and kept open from 10.30 am to 6.00 pm. this Reference Hall has the capacity to accommodate 50 students at a time and it is being used extensively.

S. U. Patel Library, H. N. G. University, Patan
 Visitor data Year: 2009

Month	Property Counter	Reference Room	Cybercafé	Reading Room
January	930	835	315	804
February	1330	680	258	1029
March	1530	970	192	896
April	930	545	126	478
May	632	422	213	473
June	580	419	295	408
July	832	648	302	769
August	1150	896	333	577
September	1200	421	351	1000
October	945	385	251	910
November	980	646	140	2310
December	1210	784	296	2975
Total	12249	7651	3072	12629

S. U. Patel Library, H. N. G. University, Patan
 Visitor data Year: 2010

Month	Property Counter	Reference Room	Cybercafé	Reading Room
January	892	611	208	4211
February	1497	691	216	4909
March	1820	1091	145	5897
April	963	506	121	2283
May	548	428	102	1000
June	594	300	127	982
July	868	871	241	669
August	1193	893	271	587
September	1533	875	457	1532
October	1635	895	229	3874
November	1213	433	52	1963
December	2063	1029	227	2587
Total	14819	8623	2396	30494

S. U. Patel Library, H. N. G. University, Patan
 Visitor data Year: 2011

Month	Property Counter	Reference Room	Cybercafé	Reading Room
January	1331	892	166	1273
February	1664	851	184	1123
March	1902	939	124	814
April	1011	229	38	2064
May	424	452	72	1156
June	918	445	423	1163
July	1012	843	306	531
August	1403	690	225	726
September	1353	923	196	1796
October	1233	504	163	2190
November	1035	627	81	1320
December	1015	977	129	3910
Total	14301	8372	2107	18066

S. U. Patel Library, H. N. G. University, Patan
 Visitor data Year: 2012

Month	Visiting	Property Counter	Reference Room	Cybercafé	Reading Room
January	-	411	679	251	1472
February	-	996	543	305	2738
March	-	702	706	427	2151
April	-	2161	560	140	2130
May	-	1490	338	230	1277
June	2741	714	331	247	827
July	4279	803	936	301	1456
August	4164	1026	951	324	3638
September	2932	964	1255	313	180
October	3271	1572	1227	274	3714
November	649	265	419	133	1318
December	3355	593	1109	179	5331
Total	21391	11697	9054	3124	26232

S. U. Patel Library, H. N. G. University, Patan
 Visitor data Year: 2013

Month	Visiting	Property	Reference	Cybercafé	Reading
		Counter	Room		Room
January	1536	1141	902	350	4695
February	2669	1286	826	357	3161
March	3016	1561	945	305	5026
April	2695	1433	726	258	3873
May	1288	1046	879	349	1746
June	1528	432	912	435	346
July	5829	1360	1321	259	4197
August	6188	1980	1234	252	4145
September	3180	1654	882	291	3143
October	4909	224	845	254	4520
November	2452	1780	482	299	3031
December	3067	1896	681	294	4507
Total	38357	15793	10635	3703	42390

University Publication

One of the functions of the University is to encourage research and creative talents. It must also keep the general public informed of its various academic and extra-curricular activities. The University has received a donation of Rs. 7.50 lakh from the Bhogilal Laherchand Family Trust to constitute a publication fund to finance its publications. It has also received a donation of Rs. 7.5 lakh to conduct research in the literature authored by the great Jain Saint Hemchandracharya and to bring out publications on the said research. To accomplish this purpose the University regularly publish the following.

(1) **"UDDICCHYA"**

It is a forthrightly news-letter. It is published regularly on the 1st and 16th day of every month. It is a source of official information about the decisions of the University authorities and about the orders and instructions issued under various provisions of the University Act. It functions as a link between University and affiliated colleges.

In addition to the official matters, the news letter reports important activities within the University campus and in affiliated colleges. It has a corner for

counseling students and a section for the exchange of pen friends. There are book-reviews by University Librarian.

The University appreciates to receive financial assistance from donors for the publication of this news-letter and pleased to note that in addition to colleges a sizable number of students have become subscribers to it. The news-letter has become a bridge between the university and society.

(2) **ANARTA – University Research Publication**

It is a twice a year Research Journal. It is published regularly June and December of every year.

Automation

UGC has sanctioned Rs. 7.50 lakhs under the plan of computerization and networking of University Libraries for the purchase of computer system. Out of this grants the library has acquired necessary equipment as suggested by the INFLIBNET centre. With this systems the library has made a beginning in creating database of books using SOUL 2.0 software currently data of the 68,215 books have been computerized by using of SOUL Software Developed by INFLIBNET.

Membership

BRITISH LIBRARY : www.britishcouncilonline.org

DELNET (DELNET ONLINE) : www.delnet.nic.in

INFLIBNET CENTRE : www.inflibnet.ac.in

Bentham (Pharmacy) : <http://ingentaconnect.com/content/ben>

1 Guruvandana Granth Sanskruti Vykhannamala.

Shri Manibhai Prajapati (Ex. Librarian and Co-ordinator, Dept. of Library and Information Science, H. N. G. University, Patan) has donated Rs. 1,11,111 on 14 / 6 / 2009 for the lecture series.

2 Manav Chetana Urdhvarohan Saptah

“Manav Chetana Urdvarohan Saptah” organized every year by the university library. (2012 Speaker : Shri Rohit bhai Shukla, Shri Pravinbhai K. Baheri, Shri Vidhyutbhai Joshi.)

3 Mohanlal Patel Bhartiya Sahitya Vyakhyanmala.

Shri Mohanlal Patel "Amrut Parv" Committee had donated 5,00,000 lacks on 28-12-2001 for the Shree Mohanlal Patel Bhartiya Sahitya Vyakhyanmala. University Library organized Lecturer Series From the interest received from donation amount "Amrut Parv". (Shri Mohanlal Patel Bhartiya Sahitya Vyakhyanmala. Subject : Mahatma Gandhi Aur Rabindranath Tagore. speaker : professor Indranath chaudhari, Date : 11-01-2012.)

Shri Mohanlal Patel Bhartiya Vyakhyanmala. Subject : Bharatiya Navjagaran aur Narmad. Speaker Pro. Mahavirsinh Chauhan. Date : 12-02-2014.

4 Shree Umashankar Joshi Vyakhyanmala.

Late Umashankar Joshi lecturer series is also organized every year by the university library. Pannalal Patel Janm Shatabdi Samaroh Lecture Series Organized the university Library Speaker (i) Padhma Shree Bholabhai Patel (ii) Shree Raghuvir Chaudhary (iii) Dr. Balavant Jani (iv) Dr. Chandrakant Sheth. (v) Dr. Manilal H. Patel. (vi) Dr. Kishorsinh Solanki. Date 23-3-2013.

Shri Umashankar Joshi Vyakhyanmala. Subject : Umashankar Joshini Kavyarachana : Karna-Krushna. Speaker (1) Shri Ratilal M. Borisagar (2) Pri. Dr. Kishorsinh Solanki (3) Shri J. B. Vora. Date : 21-01-2014.

Group Discussion (Budhvariya) Actively participated in Weekly Group Discussion organised by HNG University Library from 1996 till Date.

Work in Under Process

Established E-Library
Wi - Fi Library
Web OPAC
Web Design for Library
E-Journal's Depository
Shodhganga for Ph.D. Thesis

Future Planning Depend on UGC Grant

Sr. No.	Head	Expenditure
1	Separate Reading Room-300 Sitting capacity with AC (New Building)	Rs. 1.5 Carore
2	Digitalization (Rare Collection)	Rs. 25 Lacks
3	Local Area Collection Development (Local Books = 15 Lacks History, Culture, Literature Collection)(Books and Including Stacking Facility)	

4	Ph.D. / M.Phil. Thesis Digitalization (On line)	Rs. 25 Lacs
5	Digitalization of Ph.D. Thesis of college and University Teacher / Employees Who were taken Ph.D. degree from other universities	Rs. 5 Lacs
6	Reference Books	Rs. 75 Lacs
7	Miscellany Books	Rs. 75 Lacs
8	Journals	Rs. 50 Lacs
9	Cyber Café With 25 Computer	Rs. 12 Lacs
10	National Level, State Level Seminar Workshop's	Rs. 15 Lacs
11	E-Journals	Rs. 25 Lacs